

# Information and Communication Technology

Classes XI-XII and Alim

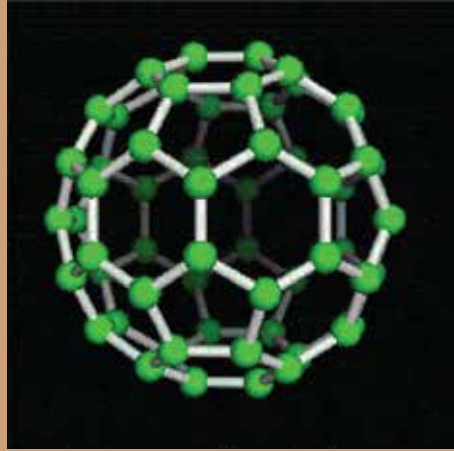

NATIONAL CURRICULUM & TEXTBOOK BOARD, BANGLADESH

Prescribed by the National Curriculum and Textbook Board as a textbook  
for classes Eleven-Twelve and Alim from the academic year 2021-2022

---

# Information and Communication Technology

Classes Eleven-Twelve and Alim

**Written by**

Mo. Tahmid ul Islam Rafi

Tamim Shahriar Subin

Forhad Monjur

Mohammad Nure Alam Siddique

Lutfur Rahman

**Edited by**

Dr. Muhammed Zafar Iqbal

**Translated by**

Fuad Bin Naser



NATIONAL CURRICULUM AND TEXTBOOK BOARD, BANGLADESH

**Published by**  
**National Curriculum and Textbook Board**  
69-70, Motijheel Commercial Area, Dhaka

---

[All rights reserved by the publisher]

**First Publication : February, 2022**

**Reprint : , 2023**

**Design**

National Curriculum and Textbook Board, Bangladesh

Price: Tk. 150.00 (One Hundred and Fifty) Only

---

Printed by:

## Preface

The aim of secondary education is to make the learners fit for entry into higher education by flourishing their latent talents and prospects with a view to building the nation with the spirit of the Language Movement and the Liberation War. To make the learners skilled and competent citizens of the country based on the economic, social, cultural and environmental settings is also an important issue of secondary education.

The textbooks of secondary level have been written and compiled according to the revised curriculum 2012 in accordance with the aims and objectives of National Education Policy-2010. Contents and presentations of the textbooks have been selected according to the moral and humanistic values of Bengali tradition and culture and the spirit of Liberation War 1971 ensuring equal dignity for all irrespective of caste and creed of different religions and sex.

Honourable Prime Minister of the Government of the People's Republic of Bangladesh Sheikh Hasina expressed her firm determination to make the country free from illiteracy and instructed the concerned authority to give free textbooks to every student of the country. National Curriculum and Textbook Board started to distribute textbooks free of cost since 2010 according to her instruction. In its continuation, this textbook has been reviewed and updated with a view to create a developed and resourceful Bangladesh keeping vision 2041 ahead.

Creating a human resource skilled in information and communication technology is one of the mediums of implementing digital Bangladesh. With that view in mind, the National Education Policy has emphasised on making **Information and Communication Technology** compulsory from grade VI to grade XII in all streams of our education system. The curriculum and the textbooks of this subject have been developed to promote that purpose forward. The National Curriculum and Textbook Board has developed the Information and Communication Technology textbooks for grade XI-XII and Alim level according to the decision of the Digital Bangladesh Taskforce Executive Committee. We hope that this textbook will develop learners' keen interest in this subject in addition to imparting information and communication literacy to them which will play an effective role in creating digital Bangladesh.

I thank sincerely all who were involved in the process of revision, writing, editing, art and design of the textbook for their intellectual labour.

**Prof. Md. Farhadul Islam**  
**Chairman**

National Curriculum and Textbook Board, Bangladesh

## **Contents**

<b>Chapter</b>	<b>Title</b>	<b>Pages</b>
<b>First</b>	Information and Communication Technology: World and Bangladesh Perspective	1- 40
<b>Second</b>	Communication Systems and Networking	41- 76
<b>Third</b>	Number Systems and Digital Devices	77-117
<b>Fourth</b>	Introduction to Web Design and HTML	118- 148
<b>Fifth</b>	Programming Language	149- 196
<b>Sixth</b>	Database Management System	197- 222

## Chapter One

### Information and Communication Technology: World and Bangladesh Perspective

---



Launching of Bangabandhu-1 Satellite

Like the Industrial revolution that changed the course of human history, we too are going through a revolution right now that we are calling the revolution of information and technology. The unique thing about this revolution is that it has touched the life of almost everyone around the globe. This is the first time the human species has created an environment where they can exist as a single organism wrapped up in the comforts of cooperation and empathy of one another.

**After completing this chapter the students can-**

- Explain the concepts of global village
- Know the elements of a global village
- Learn the contribution of information and technology in establishing global villages
- Learn about virtual reality
- Know about the effects of virtual reality in our daily lives
- Learn the recent trends of information technology
- Explain the importance of morality while using information technology
- Evaluate the effects of information technology in society
- Explain the role of information technology in economic development
- Respect the values regarding the use of information technology

## 1.1 Concept of a global village

---

Peaceful and serene are the two words that come to mind when we try to picture our ideal village. In an ideal village, everyone knows everyone, they care about each other, they share their happiness and as well as their griefs. The amount of care and empathy the villagers share among themselves can not be imagined by people living in urban areas. So what if the geographical distances did not matter and we could live in peace and harmony with each other, ignoring the political, economical, racial and religious divides - just like the villagers do? Surely the feeling of brotherhood and compassion towards everyone will drive us towards a greater sense of communal feeling and combined progress. This chain of thought led us towards the concept of a global village.



**Figure 1.1:** Canadian philosopher Herbert Marshall McLuhan

The unimaginable progress of information technology and rapid increase in sharing of information between people from all over the world are building new relations and binding us together in such a way that for the first time the concept of creating a global village seems possible. Due to the advent of technology, we can certainly feel that no one in the world is too far away or too disconnected from us, as an individual.

In the 60s, acclaimed Canadian philosopher Herbert Marshall McLuhan first proposed the concept of how electronic technology and fast dissemination of information can elude the concepts of space and time to turn the whole world into a village. The global village provides such an environment or a society where people from different parts of the world are connected through information technology. They can communicate and extend a helping hand to one another. The globalization of information technology has allowed everyone the unlimited and accessible flow of information as well as enabling a greater improvement of lifestyle, increased work efficiency, business and commerce, remote learning, remote health care and created new vocations all around the globe. Now we can easily and immediately provide the latest products of our civilization to everyone's doorsteps. But to achieve this we need to create awareness, increase abilities, utility knowledge and efficiency among us. We also need connectivity with Network, Hardware, Software and the ability to collect and analyse from trusted data sources.

The downside of free and available information is the invasion of fake news and untrue information which sometime creates chaos at a national level, invasion of privacy, cyber attacks and technological inequality. A handful of information technology based corporations control all of the data which is seriously creating imbalance in the global equilibrium. In the light of that, let us discuss the principal components regarding the concept of a global village.

### **1.1.1 Communication**

For a long time our concept of communication was to travel between two different places. Communication means a whole different thing right now and it plays one of the most important roles in the concept of a global village. Though we have made quite a huge progress over physical transport, yet it takes us a couple of hours to travel to different parts of the world. But from the perspective of a global village, communication means the exchange of information and messages in the wink of an eye. Be it through writing or through audiovisuals, the exchange of information is called communication and is the principal component in the concept of a global village.

As a result, each new information technology invention has brought a revolutionary change on how we communicate. We have left behind the decades old wired telephones in favour of wireless mediums like mobile phones, fax machines, emails and internet. We can now instantly connect to any part of the world through the use of these modern communications.

We can generally classify communication into two types - telecommunication and information communication. As mentioned before, there was once a time when wired telephone was the only possible method of telecommunication. But the invention of wireless telecommunication made way for different devices like mobile phones, radio, television and walkie talkies.

On the other hand, sharing and exchanging information by following all the protocols and security measures is the most important aspect of the modern information technology age. These include the internet and services based on the internet like email, social media, video conferencing, websites and such. Email is a way of exchanging messages with people using the internet. Nowadays a person's email address has become more important than their physical address. Social networking is used for sharing and communicating a person's information, photos, videos and news with others. Recently many social and political revolutions have been sparked from social networking websites. Video conferencing is an audio-visual way of arranging



virtual conferences and meetings. Almost every organization and corporation of the world makes their presence and works known to the world through websites on the internet. These internet services gained rapid popularity because they save a lot of time and money and bring better results.

There is of course a flip side to all of these, the over-dependence on internet and social networking services has led to addictive behaviors in the younger generation. These adversarial effects have made the world rethink and re-evaluate the use of these services.

### **1.1.2 Employment**

Unemployment has been a major headache for every country of the world. The advent of information technology and communication systems has allowed a huge number of the population to apply for work and to do work anywhere in the world while staying at home. This opportunity has provided an answer to many of the problems related to the unemployment. Even in Bangladesh, we have such job and employment related portals providing their services for almost two decades. Among them [www.bdjobs.com](http://www.bdjobs.com), [www.chakri.com](http://www.chakri.com) and [www.everjobs.com](http://www.everjobs.com) are prominent examples. One can use these websites to apply for jobs online while keeping their personal information secured. There are also a huge number of opportunities to work for companies outside the country while at home. Using the wonders of information technology and modern communication, a citizen of one country can easily provide their services to an organization of a different country. This type of remote work is known as outsourcing. We have an Information Services Center in every union of our country which created many new opportunities for work and also inspired entrepreneurs to create work opportunities for others. Services like Uber and Pathao deserve a special mention here. They have created numerous job opportunities for people while providing transport services to the mass. One can also use their own expertise and skills to work for an organization on a part time or project basis all the while sitting at home. These types of jobs are gaining popularity as they provide a chance to work from one's own comfort zone and do not have a strict time and location boundaries. This type of part time or project basis work is known as freelancing. Globally popular freelancing websites such as Upwork, Freelancer, Fiverr, Belancer offer opportunities to different types of work including data analysis, copywriting, graphics design, software development, affiliate marketing, search engine optimizations, AdSense, virtual assistance, research and survey, article writing and many more.

While earning from freelancing work seems enticing from hindsight, it demands a very different lifestyle. Separation from family members while staying at home is a big sacrifice to make in this vocation. Working late night shifts, not getting work matching one's skill level, mental stress, lack of proper evaluation and difficulties in payment are some of the negative aspects of freelancing works. More importantly though in our country freelancing jobs are not yet socially recognized as a viable vocation, many are discouraged to pursue them.

### **1.1.3 Education**

Education is a vital component on the concept of a global village. Only a proper education can grow awareness of society and environment in a person, make him a freethinker and a compassionate global citizen. In this rapidly changing world, old ways of learning things are left behind to make way for modern day education befitting for this day and age. Education systems are being evolved with the development of information technology. Keeping pace with the talent and ability of young minds is no small feat.

Information technology is a very powerful tool which can be used in both institutional and casual learning environments. It allows students access to the infinite source of knowledge, assistance from teachers and learning materials from educational institutions around the world. Costly textbooks were a real problem to education once. Nowadays e-books have granted the students access to the same textbooks for free or at a low cost. One can download any textbook published from our National Curriculum and Textbook Board for free from NCTB's official website. The concept of global village preaches that a student does not have to go to another place or to another country to receive their desired education. Now they can do it from their home. During the 2020 COVID-19 pandemic, most schools, colleges and universities around the world resumed their curriculum from online services. Teachers used different applications like Google Meet, Webinar, Imo, Skype, Zoom, Whatsapp to provide live classes to their students. Many have also produced video tutorials and lectures for different topics and distributed them to the students with the help of social media and communications websites. In present days, a student can watch video lectures, complete and submit assignments while taking advantage of the full course curriculum of a foreign university remotely. Education is no longer constricted to geographical boundaries. That is why information technology is becoming increasingly popular in serving education to every student in the world.

E-learning is the process of delivering education using electronic mediums and online services like the computer and internet. E-learning is a system that can provide interactive learning experience to students from anywhere with the help of technology. Currently this is the most used in a selected number of online courses and educational programs. However, despite the E-learning system can provide a learning experience to a huge number of people at once, the lack of human interaction is a barrier that is holding back its full adoption in many countries. But this system has proven to be very effective in delivering training programs to development sectors and corporate officials in general.

#### **1.1.4 Medical Facilities**

Even in this modern age, we still have many remote parts of the world where people do not have any hospitals, medical facilities and means of communications available. There are areas which are so remote and out of reach that it takes 2-3 days to take a patient to the nearest hospital. Not only the furthest parts, even many of the wealthiest nations do not have universal medicare facilities. Public healthcare is neglected in many countries and as a result it is really tough for the poorer population to get proper healthcare. Telemedicine can play a vital role to bring healthcare facilities to everyone's doorsteps.

Telemedicine is a system where doctors and healthcare professionals use information and communication technology to remotely provide healthcare to the patients. Telemedicine aims to extend the reach of healthcare to the mass population. In the last few years, remote areas of Bangladesh have been using information and communication technology to provide healthcare. Although there are many limitations, little by little the hospitals in the wards, unions and upazilas have started adopting teleconferences and video conferences to provide healthcare services. Patients have started sending their test reports via emails which have made the process much easier. Now a doctor can consult with a more experienced and specialist doctor with the help of video conferencing before a complicated operation procedure. Many websites such as Teladoc, Maven Clinic, iCliniq, MDlive, Amwell, Doctor on Demand, provide online healthcare services to every part of the world. During the 2020 COVID-19 pandemic, every country had several hotline phone numbers where the doctors provided telemedicine services to the people 24/7.

Detecting the ailment is the essential step to a proper treatment. Artificial intelligence is widely used in the present world to pinpoint symptoms and diseases and deliver effective treatment. Now Electronic Health Record or EHR databases are used to keep track of a patient's treatment history. A patient can use the EHR to get his medical and treatment history from anywhere in the world. Therapy Notes, Epic care, Next Gen Ambulatory EHR, Care 360 are some prominent softwares used for this type of work.

### 1.1.5 Research

Research is a process where one can use their creative thinking, data and talent to enrich the knowledge base of the world. Research work is one of the most important prerequisites of development. Rigorous studying and scientific study of a subject matter are related to research. Developed countries generally use a huge amount of budget behind different research works.



Figure 1.2: Young researcher working in University facilities

That is why research works are integral parts of the concept of a global village and information technology plays a very important role here. Scientists and researchers in the present world can not even think of a life without information technology. Collecting, storing and processing huge amounts of data, complex mathematical calculations, simulations, operating and controlling machineries - all aspects of modern research work are bound to modern information technology. Scientists and researchers can keep constant communication with each other, share thoughts and opinions and enter discussions about their work using the internet. They can use the internet to attend conferences and seminars from all over the world and learn more about the ongoing research works in their respective fields. In a not so distant past, publishing a journal or patenting an invention was a very complicated process which was a great obstacle to research work. But now most of the journals are published online as e-journals and most of the patent databases are open for all so that any researcher can access and use the data and information they need. That is why many of our universities are doing world class research work despite their many limitations.

Researchers are now using their websites and blogs to keep everyone updated about their ongoing works. This way the result of a certain research, the accuracy of the collected data and assumptions are available to all the researchers and scientists to scrutinize and make perfect, thus advancing and speeding up the whole process.

### **1.1.6 Office**

Office or workplace is a place where professionals usually ply their trade. A modern day office is a great way to expand upon the concept of a global village. Whenever we call a company via phone or internet for any query, we can never be sure from which part of the world they are answering from. Modern office equipment, softwares and the internet have made office work more efficient, fast and transparent. Government offices, corporate offices, research laboratories and all other kinds of workplaces are connected via the internet and have most of their works automated. Day by day most of the office documents are becoming digitised making the offices paperless and filing cabinets obsolete.

With the blessings of modern technology, modern workplaces have been revolutionized to the point that people are working remotely from their home without worrying about work hours. We have a 12 hour time difference with North America, so one can maintain two offices in these two countries and both shifts in both offices can work the full 24 hours a day. We can share and collaborate in documents using services like Dropbox, Office 365 and Google Drive. We can store files and documents securely in services like these and access them from anywhere. We can attend or organize any office meeting using video conferencing and get the same results the away we do face to face meetings.

On the contrary automation or digitalization of offices is affecting people who do not have particular experiences and skill sets to go unemployed. Direct interaction with clients and coworkers are being diminished too which is affecting our social relations. There is also a risk of security if the national important data storages are not maintained with extreme care and caution. So we must consider all the flip sides while moving towards modern technology.

### **1.1.7 Residence**

Having a roof over one's head is a basic need of mankind. The use of modern information technology in residences are rapidly increasing within the concepts of a global village. One can now sit at home and communicate with their friends and family, use a remote controlled security system, control the light and temperature of the residence, do grocery shopping, have remote healthcare and every mode of entertainment available right in the palm of one's hand. Technology has made our lives easier and more comfortable than we had imagined.

A residence which has these kinds of facilities is called a Smart Home and the facilities are called Home Automation System. In a Smart Home, devices like the air conditioner, garage doors, blinds, lights, fans, washing machines, ovens, entertainment systems all are connected to be controlled from a one stop service.

Smart Home can be equipped with Smart Home Camera and motion sensors which are directly in contact with law enforcement agencies to ensure the security of the home. Smart Home is especially useful if you have a physically disabled or old person staying at your home. You can use voice commands to do most things in a smart home like opening and closing of doors and windows, controlling temperature and lights and such.

There are still issues with invasion of privacy, mismanagement, not knowing how to use the technology properly and many other limitations. But despite that, the home automation system is gaining popularity everyday.

### **1.1.8 Business**

No country in this world is self-sufficient enough that they do not have to depend on other countries. A country produces some products also and they export it to other countries who need them. The concept of a global village takes it full form when it comes to business and trade. A country's development is based on a strong economy which in turn is fueled by increase in business and trade inside the concepts of a global village. Technology has done wonders in the field of business too. Now a buyer and a seller do not need to meet anymore, they can easily buy and sell products online. The spread of e-commerce and online shopping tells us how much the technology has influenced consumer and producer behaviors.

E-commerce is a modern age system where data processing and computer networking is used for the sales, distribution, shipping and any kind of transaction regarding a product or a service. E-commerce websites generally list the available products alongside their prices, qualities and shipping information with other useful details and multiple pictures. [www.bikroy.com](http://www.bikroy.com), [www.daraz.com](http://www.daraz.com), [www.alibaba.com](http://www.alibaba.com), [www.amazon.com](http://www.amazon.com), [www.ebay.com](http://www.ebay.com) are some of the popular E-commerce websites inside and outside our country.

Despite some major and minor setbacks, the e-commerce business has taken off in Bangladesh for quite some time now. Now business owners frequently use social media to promote and market their products and services. Advertising through the

Internet opens the door to the world to the businesses as now they can market any of their local products to the global marketplaces. For money transactions between businesses or banks, Electronic Fund Transfer or EFT systems are now regularly used. EFT is an electronic transaction system operated and controlled by computer networks. Nowadays every bank offers an online banking solution where you can access most of your banking needs from online using the internet. This is also known as Internet Banking. A client can use the banking services without even visiting a branch and perform transactions using his smartphone, computer, debit or credit cards.

### 1.1.9 News

News is one of the main components to the concept of a global village. With the advancements in Information technology, news media have rapidly risen in efficiency and scope. Any news from any part of the world can be delivered globally in an instant.



Figure 1.3: Some daily newspapers of Bangladesh

Important news agencies like AP, Reuters, BBC, CNN, Al Jazeera are using their networks to gather news from around the world to be delivered to us at a moment's notice. Proper representation of natural disasters, wars, plagues and famine inspires compassion and empathy among people around the world. For example, the Black Lives Matter movement in the US gained popularity through news and social media and the movement spread from the US to everywhere in the world.

Our country is also reaping the benefits of this revolution of news media. Online journalism has become a mainstay in our media at present. We can easily fact check a news by cross referencing them on the Internet. Every major newspaper publisher in our country has their own online version on the internet. Telecommunication companies are redistributing breaking news and news updates as a service. The world news has become one and that is bringing us even closer. In this age, information is a power and a tool to move towards sustainable development of a country.

But the advantages of availability and the relative ease of creating a news website on the Internet, people are misusing the news media a lot. Spreading misinformation, along with creating harmful propaganda has already become a huge problem of the modern world. To counter this we need more sophisticated servers and technology as well as Artificial Intelligence systems to detect and prevent the spread of misinformation and fake news.

### **1.1.10 Entertainment and Social Communication**

Entertainment is a huge part of human life. Since the beginning of civilization - music, storytelling, dance, performing arts have been the main source of entertainment for humankind. At present, most if not all of the sources of entertainment have become electronic device dependent. Through satellites and the internet we can enjoy entertainment programs from any part of the world at any time. Hollywood movies were once considered as the pinnacle of entertainment, now online streaming services like Netflix and are challenging that notion. Internet Gaming, IP TV, video sharing platforms allow the people numerous ways to get their entertainment. Before the internet age, entertainment programs were produced keeping the local culture and trends in mind. But in the age of internet, people are making contents that are attuned with the global culture and trends. Keeping with the concept of a global village, we are getting accustomed with the cultures of other nations and races regularly.

Smart phones have made consuming entertainment easier as all types of music, movies and stories you need to see and hear are right in the palm of your hands. Using social media like Facebook, Twitter, Instagram, Whatsapp, one can get updates on their favourite types of entertainment and even scope out what is good and what is bad based on the number of 'likes' on social media posts. People can now share their creation, discuss and debate the values of entertainment products and share reviews and opinions about stuff with people all over the world. Entertainment industry is truly embracing the concept of a global village in its true sense.

There are risks of course, in the progression of global trends some of our local unique cultures and traditions are dying out to make way for foreign cultures. Addiction to social media and device based contents are increasing loneliness and depression among young people. There are invasions of privacy, blatant plagiarism, lack of empathy and common etiquettes are forgotten while communicating on the internet which do not bode well for our future generations.

### **1.1.11 Exchange of Cultural Activities**

Culture and creativity play undeniable part in the advancement of human civilization. As we have made progress in our technology and economy, the advancement and expansion of cultural activities are worth a mention. Bangla, the language we speak in was not like this thousands of years ago. The language has evolved through the ages like any other cultural phenomena. Globalization is starting to have some lasting effects in our culture too. We did not use to have Valentine's day celebrated in our country, but



at present this has become an unavoidable thing for the youths. A Bangladeshi teenager in this day and age is using the same technology as an American teenager. So they are bound to see things in the same light despite their cultural and social differences. Technology is helping us cross the language, culture, race and nationality barrier and fully embrace the global village concept.

As with everything there is an adverse effect too. Underdeveloped countries are facing real challenges to keep their language, lifestyle and culture alive in this age of the Internet. More and more traditions and cultural activities are being lost everyday. The advent of pop-culture, habit of fusions and remixes are damaging the originality of long held traditions and festivities. The right thing to do is to promote your own unique and original culture and traditions on the internet in a meaningful way. Raising awareness through blogs, documentaries and forums can be a great way to sustain our traditions and culture all the while embracing the new age.



Figure 1.4: Now people from around the world can enjoy the traditional performing arts of Bangladesh

## 1.2 Virtual Reality

The term virtual reality seems like an oxymoron, how can something be a reality if it is virtual? Well, we have developed a technology through which we can create an environment where the virtual environment can be felt real in our brain. Humans generally use their five senses to create feelings in the brain through which we can perceive reality. So if we can use some machines and technology to replicate those same senses and



Figure 1.5: Affordable VR goggles made by Bangladeshi entrepreneurs

feelings, then we can trick the brain into thinking the virtual world to be real. This can be achieved in multiple ways. Sometimes you need to wear special glasses or a helmet where you will be shown two different images to create a 3 dimensional image in your brain. The same feeling can be created by projecting a 3D scene onto a screen. Using a combination of hardware and softwares, we can create a 3 dimensional imaging of a

particular environment or a scene. So we can say that virtual reality is an environment where we use hardwares and softwares to create a presentation of a virtual perception and as a result the user perceives it as a reality.

To create a virtual reality environment, we need to assemble powerful sensors and high definition computer graphics. The difference between regular computer graphics and this is, the sense of touch and sound are involved in this. Head Mounted Display or HMD is used to create this perception and exclusively made gloves and boots are sometimes used in conjunction so that users can interact with the virtual environment better. The whole process is remotely controlled through a process called telepresence. In this process real sound effects are used so that the users can have a better experience.

### 1.2.1 Impact of Virtual Reality in Everyday Life

**Entertainment:** People know virtual reality mostly through entertainment purposes. We experience 3D graphics which are based on virtual reality in almost all of the science-fiction, fantasy, historical and mythological films, shows and games. Many virtual reality based games have gained great popularity in recent times. Now people can have a tour at the farthest museums and historical places using a form of virtual reality named Augmented Reality. Augmented Reality uses real life environment elements to create and augment a virtual environment.

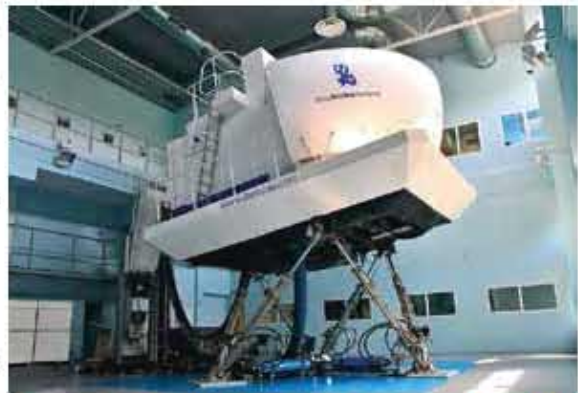

Figure 1.6: A flight simulator for training of new pilots

**Driving and Training:** Most realistic use of virtual reality technology is done by pilots in flight simulators. They use flight simulator type softwares with appropriate hardwares to get a realistic feeling of flying aircrafts before getting on an actual one. With the technology of virtual reality, you can learn to drive trains, ships and cars with accurate details and measures.

**Education and Research:** A computer generated modeling of a real life scenario is called a simulation. Education and training programs use virtual reality, simulations and modeling technology to present complex topics in an interactive and interesting

manner. Presenting research results, modeling and presenting atomic structures or the models of a DNA or RNA is easily possible through the technology of virtual reality.

**Healthcare:** Healthcare has wide ranges of use of virtual reality. Complex operation procedures, attaching and designing prosthetic limbs, modelling cells and DNA training young and inexperienced surgeons are some arenas where the technology is already being used.

**Warfare:** Using virtual reality one can create a realistic wartime environment and provide many wartime scenarios for new recruits to train on. With this the soldiers can prepare themselves for different situations without having to face the actual situation.

**Business:** To predict and project the expected value and outcome of a product, designing a product or evaluating a product has become a lot easier through virtual reality. Handling of hazardous materials and dangerous training are being done by virtual reality now to keep employees out of danger.

Although virtual reality can be a great tool for learning and training hands on, we have to be cautious with it around children and toddlers. Different age groups react differently to the stimulus of virtual reality. So the jury is still out on this one.

### 1.3 Contemporary Trends of ICT

---

The industrial revolution was started with the invention of steam engine. The second one started with the advent of electronics. The rapid advancement in the field of Information and Communication Technology at present has started multiple industrial revolutions, according to the opinion of multiple experts. In the past, nations who were the early adaptors to the new technology during the industrial revolutions, became the world leaders eventually. So we have to take part in the ongoing industrial and technology revolution to put us ahead in the race. Information technology has touched the lives of the people of the world in meaningful ways. This technology more or less depends on the intelligence of a human being. So for the first time in human history, it has created equal chances for the rich and the poor to use it and thrive. Some nations are already aggressively using and putting their dependence on the information technology revolution. Despite our limited capabilities, our country is also moving towards creating a Digital Bangladesh using the fruits of information technology.

Now we will discuss the fields that are greatly influenced by the progress of information technology.

### 1.3.1 Artificial Intelligence

Intelligence, comprehension and analytical abilities are instinctive in human beings. When a machine is given the intelligence and ability to learn, comprehend and analyze, it is called an artificial intelligence. Just a few years back the concept of artificial intelligence was a stuff of pure fantasy and musing. But at present it has become a part of our day to day life. The main reason for this innovation is the advent of digital and information technology. We have so much data about so many things that we need a super powerful computing system to manage and process those data. We now have that much power in our computing systems.

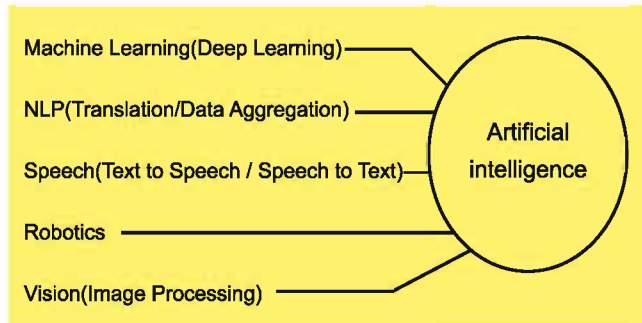

Figure 1.7: Different fields of Artificial Intelligence

Simple computer programs are often not enough to process this data or information. Special algorithms or methods are needed by which the computer can find a solution and adapt itself to changes in its environment - just like humans or other intelligent creatures do. Artificial Intelligence (AI) works with such methods and algorithms. Artificial Intelligence covers a number of areas, most notably: machine learning, robotics, computer vision, Natural Language Processing (NLP), speech processing, etc. The job of machine learning is to train the computer in such a way that it can learn various rules about a system on its own and learn from its mistakes. Robotics- is the technology of automating a robot or machine using artificial Intelligence. Natural language processing facilitates the exchange of information with computer in the language that human beings normally use (e.g., Bengali, English, Arabic). Computer's vision is a way for a machine to process different information what it sees with a camera - just like humans do with their eyes. And speech processing is basically the technique of making the computer talk and listen.

Scientists and technologists have invented a variety of methods to be used for artificial intelligence. One of the most popular and widely used methods is the neural network - which acts somewhat like the human brain. You have already known that the human brain contains a huge number of neurons. By exchanging information and signals among each other, these neurons enable humans to think and feel. To mimick this, artificial

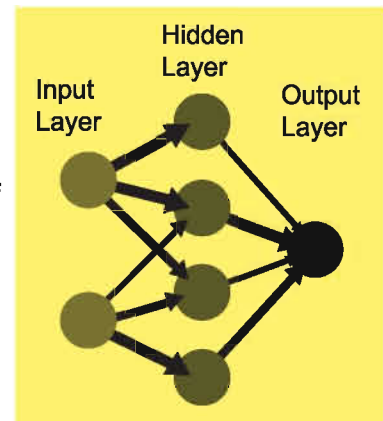

Figure 1.8: Structure of a Neural Network

neurons, called perceptrons, are created mathematically for computers. These perceptrons are then arranged in different layers and connected with each other to create a network, called neural network. The task of a neural network is to learn a function that can obtain a specific output from certain given inputs. A neural network usually consists of three layers - the input layer, the hidden layer and the output layer. As the names imply, the task of the input layer is to receive the input and the task of the output layer is to give the output of the system. In order to get the correct output for any given input, the proper values of the hidden layers must be determined. An algorithm is used for training the neural network, which means gradually changing these values until the correct values are attained. After training, the neural network can be used to determine the output for any new inputs. The more data is used for training, the better the neural network will work. It is possible to use several hidden layers instead of just one. That way, it is possible to learn very complex functions. This process is called Deep Learning. With the help of deep learning, many difficult problems are nowadays being solved by computers, which could not have been imagined even 10- 12 years ago.

C/C++, Java, MATLAB, Python, SHRDLU, PROLOG, LISP, CUSP, R programming languages are often used by developers to develop artificial intelligence systems. Programmers choose an appropriate program or language based on the function of the system.

Machine learning is one of the most successful fields of artificial intelligence. Machine learning can be broadly divided into three categories: Supervised Learning, Unsupervised Learning and Reinforcement Learning. In Supervised Learning, the machine is given many examples, from which it gathers information and learns to do a particular task. Let us suppose that we want to teach a computer how to recognize dogs and cats. In that case, it will be shown images of many dogs and cats and will be told which ones are dogs and which ones are cats. The computer will then use an algorithm to learn how to distinguish between the two animals in terms of their different characteristics. Afterwards, when it sees a new image, it will be able to identify whether it is a dog or a cat. On the other hand, in Unsupervised Learning, the computer is not given any specific label ( or name) for the data. Instead, by analyzing a lot of data, it will be able to understand the similarities or differences between them. For example, if we give computer images of many animals without naming any of them, it will realize through unsupervised learning that dogs and wolves are very similar, and that they are both quite different from monkeys and chimpanzees. In the case of Reinforcement Learning, the computer is not taught anything at the outset, rather it is allowed to work on it's own. At the end of the task, it is told how well or how poorly it performed, so that the next time the computer can change its behavior or decision accordingly. In this approach, the computer will make mistakes at the beginning. But

after several attempts, it will eventually learn to make the right decision by making self-evaluation from the mistakes. If you think about these three machine learning approaches, you will realize that they are quite similar to the way human beings learn from their environment.

A great and wondrous use of artificial intelligence in everyday life is driverless cars. Predicting weather with the help of artificial intelligence is being used for quite some time. In fact, it is hard to find a sector in the present world where artificial intelligence systems are not being applied. Health, automobile, finance, agriculture, surveillance, entertainment, exploration, research - every field in human lives has the use of artificial intelligence and it is rapidly increasing.

### 1.3.2 Robotics

Robot is a familiar word to most of us. Robot means a machine that can do physical and mental works akin to a human being. The field of science and engineering which deals with designing and producing robots is called robotics.



Figure 1.9: A walking robot built by students of a Bangladeshi University

Due to the influence of fantasy films and books, when someone says 'Robots' we think of a humanoid machine. But depending on its use a robot can be of any shape and size. A decade ago from today, the work of a robot was limited to turning screws or welding metals. The progression of technology has greatly expanded the field of robot work.

Although the field of robotics has expanded greatly, it has three distinct features that restrict its scope.

1. A robot does a particular job and is physically built according to the job description.
2. A robot needs supply of electricity to power itself.
3. A robot is controlled by computer programming.

It may be new but currently robots are widely used in places where it is hazardous for human beings to work like space exploration. Deep sea exploration handling toxic materials and so on.

#### **Application:**

1. **Hazardous Work:** Robots are widely used in fields where it is too dangerous for humans to work in. Defusing bombs and mines, handling toxic waste, tunneling under sea, handling radioactive materials are the types of work robots are better suited for.
2. **Industrial Work:** Laborious and repetitive works in factories like handling heavy materials, packaging, transfer of goods and storage are now handled by robots making the work cost effective and safe.
3. **Precision Work:** Precision works like working with microcircuits, integrated circuits and printed circuit boards are now managed by robots.
4. **Health Sector:** Dispensing medicine and performing surgery is becoming commonplace work for robots.
5. **Warfare:** Defusing bombs, handling drones and hazardous materials are being performed by robots.
6. **Education and Entertainment:** Helping people with autism and other physical disabilities, robots have come a long way in providing them with assistance, education and entertainment.
7. **Surveillance and Reconnaissance:** Surveillance in public places, scouting for important markers and providing security to VIP and public is a regular job for robots.

Alongside these works, now the robots are being combined with an artificial intelligence system which is opening more and more paths for robots to do new things in a better way.

### **1.3.3 Cryosurgery**

Cryosurgery is a surgical procedure in the realm of medical science where they use the local application of intense cold to destroy unwanted tissue. This procedure relies heavily on information technology.



**Figure 1.10: Cryosurgery Process and Probes used in Cryosurgery**

A simulation software is used to determine the position and spread of the cancerous cells. The affected area is approached with a tube with micro camera and cryogenic

gases are applied using a surgical cryoprobe. The cells temperature falls down to -41 degree celsius down to -196 degree celsius, cutting off the oxygen supply and damaging the tumor growth or cancerous cells. To reach this temperature a combination of liquid Nitrogen, Oxygen, Carbon Dioxide and Argon gases are used. These are called cryogenic agents.

Cryosurgery is a very delicate procedure and heavily dependent on technology to locate and eradicate affected cells and growths. That is why doctors are trained in this procedure with the help of virtual reality technology. Database Management Systems are used to store and retrieve patient's medical history and results of research and other medical procedures.

Cryosurgery provides a great advantage over regular surgery especially in the field of neurosurgery and cancer treatment as it is cost effective and takes very little time to perform. This procedure has no side effect, requires no prep time and post operative time for the patient.

Risk lies when things go wrong in this type of procedure. As mentioned before, this is a very delicate procedure. So a slight mistake in determining the position and nature of the affected cells might cause the cells to grow exponentially or a wrong procedure might damage other healthy cells surrounding the affected cells.

### 1.3.4 Space Exploration

When a spacecraft escapes earth's gravitational force and stations itself 100 kilometers or further away from earth's surface, we call that space travel. The world has seen many milestones regarding space explorations. On October 4, 1957- first man-made satellite Sputnik was deployed. On April 2, 1961 - Yuri Gagarin became the first man in space. While on July 20, 1969- Neil



Figure 1.11: A space station orbiting the earth

Armstrong became the first man to step on the moon. On December 2, 1971- Mars-3 craft lands on Mars. April 12, 1981 - the first Space Shuttle is launched. All of the achievements listed here are made either by the United States of America or the former Soviet Union.



To escape the earth's gravitational pull, a spacecraft has to achieve the speed of about 40,000 km/h which is almost four times the speed of sound. To reach this velocity the booster rockets in a space shuttle needs to be carefully controlled. The return path is more complicated though. The shuttle must tackle the heat generated from the friction of the atmosphere. Scientists and researchers have toiled long and hard to find proper solutions to these problems. Staying on a proper trajectory, maintaining countless machines and keeping communication with earth stations are handled by information and communication technology.

Mankind has sent a huge number of man-made satellites into the earth's orbit. Among these, some satellites are placed 34000 kilometers above the earth and they orbit the earth at the same speed as earth's rotation. So for an observer standing on the earth's surface, the satellite seems stationary in space. These types of satellites are called geostationary satellites. Geostationary satellites are essential for telecommunication purposes. Recently Bangladesh has become the 57th country in the world to have their own satellite in space by launching the Bangabandhu-1 satellite into orbit. Bangabandhu-1 is a geostationary satellite.

#### **Application:**

At present satellite Technology has gained a lot of importance. It might seem incredible but we use satellite technology in our everyday life. System in GPS (Global Positioning System) smart phones uses signals from a lot of satellites. The programs we see on the television are broadcasted by satellite. When we see a Hurricane build up in the oceans we usually have the news from satellites. Satellite helps imaging the hurricanes and our weather condition. Satellites play a important role while exploring space for example the Hubble Telescope has got numerous images of the Cosmos and helps your understanding about space.

Despite all of the positive aspects, space exploration has its own problems. Mankind has been doing space exploration for a long time and in that time the space has accumulated debris from space stations and rocket crafts that are circling the Earth at a great speed. Collision of the space debris with the existing spacecraft and space stations is a real threat now. Some countries use satellites for spying on other countries. Not only that some countries have also announced to deploy to space military forces so that they can also wage war or hostility in space. This has changed the dimensions of space travel and explorations.

#### **Bangabandhu-1 Satellite**

We are getting the following benefits from launching Bangabandhu-1 satellite:

1. Cable service providers of the country will not need to rely on foreign satellites anymore.

2. The satellite covers regions outside the borders of Bangladesh. So any neighbouring country can acquire the services of Bangabandhu-1 Satellite.
3. With the satellite we will be able to provide internet services to remote hill tracts and far areas. They will be able to reap the benefits of services such as online banking, telemedicine, remote learning and many more.
4. If any natural disaster disrupts the cellular services, the Bangabandhu-1 Satellite will be there to provide an emergency communication system.
5. The high power camera and observation equipment in the satellite will be able to provide us with valuable information about our weather, crops, hazards, geography and so on.

### 1.3.5 ICT dependent Production

Production is a process where regularly used essential services and products for the consumers are manufactured and distributed. This process needs a lot of creativity, research, knowledge and Intellectual combination. Each and every man and woman has differences in their choices and habits on one hand. On



Figure 1.12: Automated production line at Walton Factory in Bangladesh

the other hand there are advertisements and endorsements which create demands for new products and services for mankind. To serve this never ending demand of products and services, we need supply of new goods and models of old products. Application of Program Logic Controllers has greatly improved the rate of production. In modern factories, the supply chain is maintained with less need of human touch than ever. Computer operated supply lines are churning out products at an incredible rate that human hands can never hope to achieve. Using machines has greatly reduced the wastage of raw materials during the production process too.

For designing, drafting, simulating processes and managing productions - a variety of software solutions are being used everywhere. Softwares like CAD are a mainstay now for designing complex structures, machines and products. Computer aided machines and robotic hands can now cut and print any complex form and structure. Machines are used to precisely control the use of raw materials and production conditions while manufacturing chemicals, medicines and cosmetics. Productivity of workers, salaries and human resources, production planning and supply chains are also being maintained by softwares. Using modern technology one can increase the productivity of the factories manyfold and keep the factory running 24/7.

Farming and agriculture is another sector that is becoming increasingly more dependent on information technology. Production and management of crops, cattles, forestry, maintenance and distribution of the productions, raising awareness and knowledge levels - every process has been made easy with the advent of the internet and electronic media. With the help of the internet and cellular technology the farmers of grassroot levels living in the remotest areas can be reached. They can learn the latest knowledge to apply on their lands and find the solutions to their problems with the blink of an eye. Updated information on crop diseases, fertilizer usage, pesticides effects, weather conditions are vital to their production and farming. Creating new crop and farm animal species that suit a particular weather or geological conditions are only possible through the wonders of genetics and modern information technology. A lot of information about farming and agriculture can be found in various official and unofficial websites of Bangladesh.

Sugar mills are using app based services so the sugar cane farmers can stay updated about the distributions and prices of their crops. Livestock management has the aid of a lot of web and app based services too where you can easily identify a owner of the livestock with any kind of identifying features and information.

### **1.3.6 Defence**

Any sovereign state or a country needs a strong defence system to ensure the security of its citizens. Cyber crimes and terrorism also fall under the umbrella of a nation's defence.

Arms industry is closely related to every nation's defence systems and capabilities. Arms industry produces weapons for national defence and adds greatly to a nation's economy. Although this is a very old industry, information technology has given many new dimensions to this old business. Many countries do not have the capabilities to manufacture weapons but despite that they use their human resources to produce defence related software applications to use and distribute thus contributing to their nation's economy. .

ICT and defence systems work in conjunction with one another. For example bombs were operated manually once, exploding when they were thrown only. Now smart bombs and missiles are developed that can comply to orders and hit and explode at a particular time and location. Unmanned aerial vehicles and drones are being used heavily in modern warfare which are changing the landscape of a battle. Aircrafts to spacecrafts, hardware to softwares everything is applied in different ways to wage war. Internet and satellite technology are relied upon heavily in a modern battlefield.

Following are some examples of the application of Information technology in defence.

1. Virtual reality environment is used for simulation training exercises for the military. This is a much safer, cost effective and more productive solution to the old training programmes.
2. With the help of communication technology, a modern day battle commander does not need to stay on the battlefield. He can now monitor and give orders from a control station and take necessary measures when needed.
3. Satellite communications are used while conducting a battle in remote territories. Network based communications are used for broadcasting orders, monitoring situations and deliberating commands.
4. Enemy command systems can be disrupted using jamming technology.
5. Missiles can be controlled remotely to attack a target miles away from the launching site.
6. Drones can be used to spy on enemy sites or attack enemy installations from the cover of secrecy.
7. Anti-missile or anti-aircraft systems are used for detecting and defending against missile systems.



Figure 1.13: Bangladesh Army at UN Mission

At present the army, navy and airforce of Bangladesh is combinedly called the Bangladesh Armed Forces. They are tasked with keeping the peace and sovereignty of our country. Our Armed Forces are becoming more and more adept at using modern technology and tools. The Military Institute of Science and Technology has a great part to play in this matter.

Although warfare is a bane to humankind, but to advance their warfare and defence system, many countries have pushed the research and technology to the limits which ultimately benefited the general populace giving birth to new innovations and inventions. The Internet and Global Positioning System both technologies were originally developed for warfare. But in the end, the production of weapons and the whole arms industry are basically pulling and wasting all the resources of the world just to cause death and destruction. Even the testing of new weapons is always having devastating effects on nature and our lifestyle.

### 1.3.7 Biometric

#### Defination of Biometrics

Biometrics are physical or behavioral human characteristics that can be used to digitally identify a person to grant access to systems, devices or data. Even though there are billions and billions of people in the world, there are some physical characteristics and attributes that are unique markers for each individual. Biometrics can be classified into two types:

#### a) Physiological Biometrics System

- i) Fingerprint identification is a common biometrics used from the ancient times. Fingerprints are unique to each individual, which will never be the same for two persons. Fingerprint readers are used to save someone's fingerprint pattern, epidermal tissue and blood circulation into a database which can then be used to identify a person later on.
- ii) Hand Geometry Detection relies on the shape of one's hand, the length of fingers and the patterns on the palm to uniquely identify a person. This system is not very effective as the pattern on palms can change if the person engages in regular menial work or has something stuck to their palms.
- iii) Iris scanning scans for unique patterns on the iris of the eye of an individual to identify them. This scanning requires less time and is precise in identifying and detecting unque patterns. But the use of contact lenses can hamper this type of identification.
- iv) Face recognition saves a picture of a person's face and compares and saves unique facial features to identify an individual.
- v) DNA testing is the most precise and the most trusted way to identify an individual. DNA samples can be collected from any cell specimen from an individual like hairs, blood, saliva or fingernails. DNA testing is a time consuming and costly process. But it really helps while identifying dead bodies and crime scenes.



**Figure 1.14: Use of a Fingerprint Scanner Device**

#### b) Behavioral Biometrics System

- i) Typing Keystroke verification system uses an input device to measure how fast a user has typed a password and matches with his or hers previous records to uniquely identify a person.
- ii) Signature verification is an old and commonly used technique. Writing speed, stroke patterns, pressure points are used in this case to uniquely identify a person from their signatures.

- iii) Voice recognition is another biometrics technique where a microphone is used to record the voice of a user and match the pitch, tone tempo and other parameters with their previously recorded voice to identify that person. This is not very effective because illness like flu or other symptoms can cause a person's voice to change.

### **Usage of Biometrics**

Identifying dead bodies, crime scenes, finding biological parents, national identification, driving license, voter registration, ATM booths and online banking, access control, smart cards and other security measures use biometrics security systems to identify and execute their operations.

### **1.3.8 Bioinformatics**

Bioinformatics is a subdiscipline of biology and computer science concerned with the acquisition, storage, analysis, and dissemination of biological data, most often DNA and amino acid sequences. This analysis, dissemination relies heavily upon computing technology. Building genome sequence, protein sequences and storing them in a database requires mandatory computing support. The first big success in the field of bioinformatics came about when after 13 long years of toiling human genome was sequenced and published online for everyone to see. At present, technology has advanced so far that the human genome can be sequenced within hours. Cancer research is another important field for bioinformatics. In the near future every person will receive their own personalized medication which can only be possible through research on bioinformatics. The structure of proteins has been a highly researched issue for ages, bioinformatics is helping this cause too. Evolution is another important field of biological science. Bioinformatics is also helping to reveal the mysteries behind the evolution of species.

Generally bioinformatics works with four different fields mentioned below:

1. Nuclear biology and medicine: Used for data source analysis.
2. Database: Storage and retrieval of data.
3. Program: Data analyzing algorithms that pinpoint the bioinformatics information.
4. Mathematics and Statistics: Used for verifying probabilities.

Bioinformatics is used in the fields like molecular medicine, gene therapy, manufacturing medicines, waste management, climate change research, alternative energy research, biological warfare, DNA mapping, gene finding and many other spectacular new fields of research.

### 1.3.9 Genetic Engineering

Every living thing is made of countless living cells. Every cell has chromosomes which contain DNA or Deoxyribonucleic Acid, a double helix molecular structure. Every part of the DNA contains information about an organism's different attributes. A DNA can contain 20 to 30 thousand gene sequences. A set of gene sequences is known as genomes. Genomes are the building blocks of an organism's attributes and design. The longer a genome sequence is, more information can it hold. Genome sequences decide what the organism's characteristics will be.

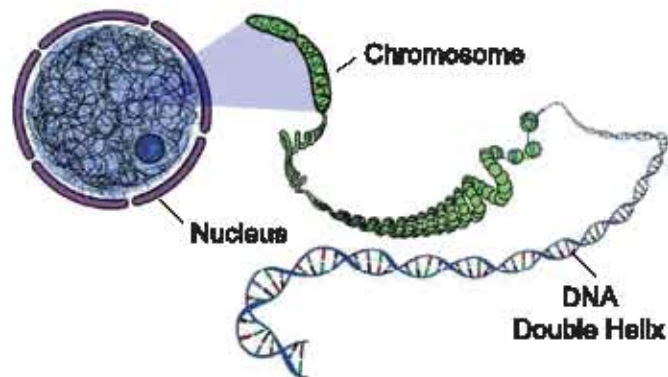

Figure 1.15: Chromosome and DNA double helix inside of a Nucleus

As the genome contains information about an organism's characteristics, one can make a change into the genome sequence and alter the organism in many ways. As the genes are part of the DNA, to change it you need to slice off that part of DNA and insert another gene sequence from another organism while in the laboratory.

Replacing gene sequences and slicing DNA is called Recombinant DNA or rDNA. Organisms that have modified DNA codes are known as Genetically Modified Organisms or GMOs. Scientists are still researching ways how to better slice DNAs and what purpose it can serve other than already discovered. Genetic engineering is the study of science that delves into discovering an organism's genetic characteristics and how to modify it with the desired effect.



Figure 1.18: Purple rice invented by Bangladesh Rice Research Institute

Basically Genetic engineering is the process of using recombinant DNA (rDNA) technology to alter the genetic makeup of an organism. It has great applications in agricultural science as we have discovered many hybrid species of crops using genetic engineering that can survive less than ideal conditions and still be more productive than natural crops.

### **Use and Usefulness of Genetic Engineering**

Due to the ever rising population, food shortage is a global problem for a long time. To meet the demand for food, every country needs to spend a lot in foreign currencies to import food and livestock. Genetic Engineering lends a helping hand solving this problem, discovering new hybrid breeds of crops and livestock that provide many times more the productions than the regular crops. Increasing the sizes of livestock, improving the weight and protein content in meat and milk is also one of the goals of genetic engineering to fight the food shortage crisis.

Genetic Engineering is being used to produce insulin and other hormones, curin dwarfism, viral diseases, battling cancer and AIDS by researching and modifying E.Coli bacteria and yeasts. Genetic engineering provides a faster and safer way to carry the desired genetic characteristics onto the next generation, so scientists are leaning on it leaving behind the old methods of selective breeding.

Different institutions in Bangladesh like the Rice Research Institute, Jute Research Institute, Sugarcane Research Institute are working with genetic engineering technology to produce better crops and livestock for our use. The crop production has increased dramatically after using this hybrid breed of crops. The Bangladesh Rice Research Institute has developed different breeds of BRRI rice which have a high production rate. They invented the Ufshi rice that created quite the stir all over the world. Recently a team led by Dr. Maqsoodul Alam discovered the genome sequence of jute. He hoped genome sequencing of a cash crop like jute would help Bangladesh economically because jute can be made disease resistant if the genome sequence is known. We discovered the genome sequence of jute which very well may restore our traditional golden crop to its former glory days. Corn, rice, cotton, tomato, papaya- many species of crops and vegetables are being experimented upon so that we may increase their production, immunity to diseases, weeds and pests.

Researches have shown that genetic engineering has its downsides too. These downsides include the decrease in biodiversity, unethical genetic mutations, decreasing the effectiveness of natural antibiotics, developing bio weapons and new deadly viruses and such.

### **1.3.10 Nanotechnology**

A nanometer is equal to  $10^{-9}$  meters. Nanotechnology is a division of science and technology that deals with developing and using anything that ranges from 1 to 100 nanometers. Any object of this size is called a nano particle. Because of its small size, a nano particle has a larger surface area so it is chemically more reactive than most other things. A nano particle can display the effects of quantum physics which is quite different from the regular objects made with the same materials. For example,



any metal can be 7 times more rigid when it is in nano particle form. This is why scientists and researchers take a particular interest in nanoparticles.

Scientists have been developing nano radius polymers and applying nano sized designs on integrated circuit chips for a long time. It is only recently we have developed tools to produce nano particles and a new vista of possibilities has been exposed to us.

With the help of this technology we can manufacture products at a much larger scale. The manufactured products are resilient, sturdy, lightweight and cost effective. The future world will be a world of nanotechnology - this is the goal the researchers have fixed their eyes upon as they develop smart medicines and nano robots to battle critical diseases like cancers. Quantum computing, creating large scale jobs, low cost energy production while minimally affecting the environment - all seems possible through the wonders of nanotechnology. Nano technology is generally applied in two variations -

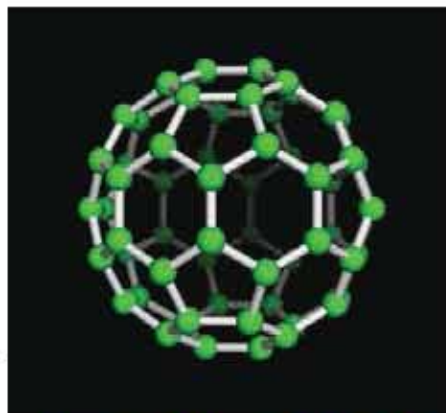

Figure 1.17: Nano particle C60, made with 60 Carbon atoms

- a) Bottom Up: In this process we start from a molecular level and build a large object.
- b) Top Down: In this process we start with a large object and reduce it to produce nanoparticles.

#### Use of Nanotechnology:

1. This is used to develop high powered, long lasting and energy saving processing units. Nanotechnology is also used to develop new display technology and quantum computing.
2. Nano robots are being used for surgeries like angioplasty, directly attending to the affected cells like nano cryosurgery, diagnosing diseases, endoscopy, angiogram colonoscopy etc.
3. Nanotechnology is used for packaging food items, improving flavors and maintaining food values.
4. Nanotechnology is being used to develop alternative fuels like Hydrogen Ion fuels, Solar cells etc.

5. This is used to produce lightweight fuel saving vehicles.
6. Different lightweight and durable sports equipment like tennis or golf balls are produced with this technology.
7. Chemical wastes from industries that are released into water supply can be countered with nano particles. Wastage from tanneries or exhausts from cars and factories can be converted to harmless components using nanoparticles.
8. Different cosmetics, moisturizers, anti-aging creams are developed using nanotechnology.

## 1.4 Ethics of ICT Usages

---

Ethics is the set of moral principles that governs a person's behaviour or the conducting of an activity. Ethics control the behavior of humans in a society by defining what is right and what is wrong. It is to be noted, though unethical and illegal are not the same thing. Not all unethical acts are illegal but all illegal acts are indeed unethical too. Recently the amount of unethical, fraudulent and illegal activities through the internet has increased to such an amount that many countries had to step up and pass laws regarding this situation. So the things that were unethical a few days ago, now they are considered illegal. Anybody can now go to jail if he/she insults someone on Facebook.

Nowadays a huge number of people are connected with each other via the internet, so ethics plays a very important role here. One can start with small unethical acts then move onto criminal activities if his/her act is not handled properly. This is why ethical education is absolutely necessary for all the present and future users of computer and the internet.

In 1992 the Computer Ethics Institute had introduced a 10-point guidelines for the users of Computer and information technology. This is known as the Ten Commandments of Computer Ethics–

1. Thou shalt not use a computer to harm other people.
2. Thou shalt not interfere with other people's computer work.
3. Thou shalt not snoop around in other people's computer files.
4. Thou shalt not use a computer to steal.
5. Thou shalt not use a computer to bear false witness.
6. Thou shalt not copy or use proprietary software for which you have not paid (without permission).
7. Thou shalt not use other people's computer resources without authorization or proper compensation.

8. Thou shalt not appropriate others' intellectual output.
9. Thou shalt think about the social consequences of the program you are writing or the system you are designing.
10. Thou shalt always use a computer in ways that ensure consideration and respect for other humans.

Users of computer, internet and mobile phones should always keep these commandments in their mind as there are many incidents of unethical and illegal activities happening on the internet. Most common of these are -

**Hacking:**

Hacking is the process of gaining unauthorized access to data in a system or computer. Most of the time they compromise an individual or institution's data and systems. Although sometimes, the hackers only notify the individual or the system administrator of the fault in their systems, without causing any malicious activities.

**Phishing:**

Phishing is the practice of sending fraudulent mails or social media communication to someone which contains a fake website link. This is done to steal the victims access credentials to a particular domain. This can be especially damaging as phishing generally targets to steal Bank and Credit Card information.

**Spamming:**

Spamming means sending indiscriminate messages to a lot of users. Usually spammers send spam messages which results in malicious scam jobs or more regularly it is just an advertisement or promotions of a product. Spammers usually collect your contact information from unsecured forums or if your mail address is public somewhere on the internet.

**Software Piracy**

Softwares are intellectual products that developers spend their intellect, creativity and many hours of hard work in making. When one uses a software without proper licenses or without purchasing this is called software piracy. Acts of software piracy includes whole or part of the software and reproduces and sells it somewhere else. A survey conducted by Business Software Alliance states that 36% of all the softwares used is pirated softwares. However proper application of copyright laws can prevent software piracy.

**Plagiarism**

Plagiarism means copying someone's work or research in full or in part and publishing it or use it as your own. Publishing without proper references also falls under plagiarism.

### **Cyber Act**

Many countries have applied different laws to stop cyber crimes. According to the 2006 Information and Communication Technology Act's Section 57(1), If any individual intentionally uploads or publishes something false, fabricated or obscene which causes defamation to someone and these false information are used to incite the public, the convicted can be charged with maximum 10 years of jail time or a maximum of 1 crore taka monetary fine. The Pornography Act of 2012 states that, if any individual uses the internet, websites or mobile phones or any other electronic devices to distribute pronography, he/she can be charged with maximum of 5 years of jail time or 2 lakh taka of fine.

Recently in 2018 the Digital Security Act was made, an excerpt of the act is as follows:

- No individual can have an unauthorized entry to important and confidential data terminals to harm, alter or derry data or infiltrate computer systems, network or modify the programming or deactivate securities.
- No one can have unauthorized access to restricted computer systems, networks or electronic devices. They can not copy or modify the information stored in there.
- No one can conduct fraudulent activities with the help of electronic or digital media.
- No one can use the digital or electronic media to defame the Liberation War of Bangladesh, Father of the Nation, Flag of Bangladesh or spread false information about them.
- Digital or electronic media can not be used to compromise the image of the country, its sovereignty and security, can not spread hate speech, defaming and inciting statements about religion, race or something that cause societal disruption.
- Digital or electronic media can not be used to blackmail someone or to defame an individual or an institution.
- Digital and electronic media can not be used to infiltrate financial institutions like banks to steal information, customer data or conduct fraudulent activities.

The Digital Act has provisions of different levels of punishment for different levels of crimes. But in the end we have to learn about the ethical boundaries and use our sense of compassion and intelligence on how to use the internet. Raising awareness is the best way to stop such crimes.

### Different Type of Crimes

We usually talk about individual hackers or small time fraudulent corporations when we are talking about cyber crimes. But the largest software corporations have committed bigger cyber crimes, were accused, convicted, and were punished too. Facebook provided their user data to Cambridge Analytica so that they could use those data for political agenda. They tried defaming Whatsapp and were fined 110 million Euros for it. Apple corporation was fined 14.5 billion Euro for evading taxes. Google has been fined 10 billion Euros to this date. Amazon is being investigated in Germany for their illegal activities. These big corporations hold the most data about the people of the world. Information is power and they control most of the information. We are going through a time where we are being controlled by a handful of big software corporations. We need to be aware of this and be wary of our usage of the internet and social media.



Figure 1.18: Bangladeshi news media covering news about tech giants

## 1.5 Impact of ICT in Social Life

This is the age of information technology. It has reached such an extent that we can not even imagine spending a single day without internet or electronic devices. It has a deep impact in human society and lives.

### 1.5.1 Positive Impacts of ICT

Education, healthcare, lifestyle, workplace, banks and factories - ICT has a great and positive impact on all of these fields. Let us briefly describe some of it:

#### Education:

ICT has enabled our educational system to provide online admission application, payment of fees, fines, admission, result tabulation and publication, registration, filling up forms and many more works over to the Internet to be done more effectively and precisely. Through the ICT students and teachers have been able to pursue courses from different institutions online, participate in quizzes and exams and study from the comfort of their homes.

**Science and Healthcare**

ICT has grown exponentially with the growth of science and research sectors through the years. On the other hand, the growth of ICT has enabled the progress and advancement of science and research in many ways. If we only try to describe the contribution and application of ICT in the healthcare sector, we can write several books about it. Disease diagnosis and detection, providing remote healthcare, telemedicine and the latest drugs and services all at the palm of your hand only possible through information and communication technology.

**Financial Institutions**

Day to day transactions of bank, smart cards, ATM machines, mobile banking, online banking, loan approvals, interest rate calculations, share exchange - now almost all financial operations in banks and other similar institutions have been handed over to computing systems and electronic devices and softwares just because the speed, ease of operations, availability and error free nature of calculation and computing.

**Workplaces**

To increase the effectiveness of work and all personnel, save cost and paper there is no denying the wonders the information and communication technology has brought to our workplaces. Human resource management, task management, salary disbursement, employee and project information collection and storage and analysis all the work have been taken over by a multitude of software solutions. Even in the courts, we are now able to lodge a lawsuit, complaint over online.

**Industries and Factories**

Advent of technology has revolutionized the supply chain management and increased productivity and distribution chain to a new level altogether. Sourcing raw materials, designing products, monitoring the manufacturing process, using robotics when in a riskier environment or if one needs precision. Demand, supply calculation, forecasting, waste management, online orders and buying - all the things that were not possible before are now being done at ease with technological advancement.

**Agriculture and Farming:**

Information dissemination has been the main progress that is made easier with the progress of information and communication technology. As an agriculture based country, use of ICT has brought forth a new era in Bangladesh. Satellite imaging, precise weather forecasting, monitoring the market conditions, supply-demand and storage management, crop cycle management, finding buyers online - all the things have been made easy with technology. With smartphones and the internet, farmers of remote areas now have access to knowledge that help them with crop cycles, what fertilizers or pesticides to use and breeds of crops and livestock.

### Communication

As with the name, ICT has ushered in a new age when its regarding communication with one another. Smartphones, Internet, social media, emails and technology as such have reached to the farthest corners of the world.

### Culture and Entertainment:

Culture and entertainment has changed to a point that it is almost unrecognizable form even two decades back. Now all the entertainment media are dependent on electronic devices and cloud services. This has enabled us to experience the culture of other countries more freely while developing a global sort of entertainment and cultural trends.

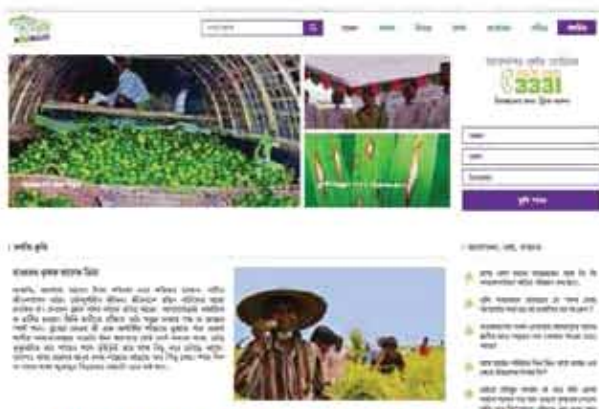

Figure 1.19: A website about Bangladesh Agriculture made with the support of a2i

### 1.5.2 Adverse effects of ICT

#### Addiction:

Addiction to the Internet has become a headache of our current society. All the other problems are just the by-products of this Internet addiction. Social media like Facebook, Twitter, Instagram, Reddit have locked the younger generation into a constant using an addictive cycle. This has caused symptoms like lack of focus and concentrations, unethical and rude behavior and attitude and many other adverse symptoms in the youth. Not only the youth many of the parents have fallen in this addictive trap, wasting hours on social media and the internet, losing their effectiveness and productivity, being less sociable, showing less concern to their children and family are common symptoms of this addiction. Online gaming is another arena of addiction that people are diving headfirst into. People are displaying behaviour similar to drug addicts while addicted to online gamings. They have resorted to doing unethical and criminal activities for the pursuit of these games. Some games have caused deaths and accidents in real life. Some games have caused suicides too. The aggressive takeover of foreign culture also had an adverse effect on our culture. Increase in violence and behavior, radical changes of lifestyle and fashion are seen with naked eyes. Increases in pronography and online bullying are also by-products of this addiction.

**Crime**

Cyber crimes, online bullying, pornography, hacking, phishing - the progress in ICT have given birth to new genres of crime and unlawful activities. Accessing unauthorized information, breach of privacy, cyber attacks, propaganda and defamation have become a mainstay with the progress of ICT in our society.

**Health Problems**

Excessive screen time on computer monitors and smartphones is causing eye problems, headaches, back problems to many at present. Depression and mental degradation are other symptoms of overuse of technology products.

In the end we can conclude by saying that ICT is only a tool like the surgeon's knife. You can use it to save people's lives or you can murder someone. It is on us how we use the technology. We have to be aware and mindful while adopting new technology and products. Society will change with the growth of information and communication technology, but which road will it take, the answer lies with us and on how we use it.

**1.6 ICT and Economic Development:**

---

Economic development is marked by the improvement of lifestyle of the populace. Improved lifestyle means better education, better healthcare, increase in income, safety of life and livelihood and above all fulfill the basic needs of the citizen. Information Technology has made our lives more comfortable, works more productive and faster. It has turned the whole world into a global village.

In the present world many countries have taken the advantages of the latest computer technology, submarine cables and satellite technology to steer onto the Information Highway. The economists have suggested that, as the developing countries can produce goods at a lower cost than the developed countries, they have more room to flourish further if they can properly utilize the advantages of modern Information and Communication Technology.

**Role of ICT**

ICT had a significant role to play in the development and rise of each and every one of the world's leading nations. Investments in this sector have risen exponentially while the productivity of the country increased many times over. While the growth of GDP in European countries are credited to the growth of the telecommunication sector, most economists pointed out that for developing countries like Singapore or Korea the growth in GDP was due to the progress in the Information and Communication Technology field.



### **Development Process**

Researches show that in developing countries economic development works hand in hand with information technology in the following ways;

- Ensure equal participation while working with education, training programs and unemployment problems.
- Enable the grassroot people in remote areas to do more by providing them with access to information.
- Availability of low cost ICT devices and equipment.
- Decrease the bureaucracy by applying an e-governance system.
- Provide every business with easy access to the larger market and maintain communication between every stakeholders.

### **Knowledge Economy**

To maintain the growth and progress of ICT, a new branch of economics has emerged which is known as Knowledge Economy. Emergence of knowledge economics in the developed countries have given rise to the need for a huge amount of data processing and analytical jobs. Developing countries have risen to this opportunity and are earning a lot of foreign currencies through this. This has increased the earnings and enabled the developing countries to find a gateway into solving their unemployment problems.

### **Situation in Bangladesh:**

Bangladesh is one of the fastest growing economies in the world. Bangladesh stands 34th in a development marker stated by the World Economic Forum and is projected to take the 24th place within the year 2030. These development indicators mark Bangladesh as one of the 'next 11 countries'.

ICT can contribute to our economy in two ways. Firstly through the activities of the Software industry. Secondly through the services that came with the growth of ICT industries. The 4% growth in production is surmised to be the direct contribution of the development of the ICt sector. Oxford Internet Institute says, Bangladesh stands 2nd among the world in the number of total online workers.

### **Software Industry**

According to a survey conducted in 2019, there are 800 registered software companies in Bangladesh. There are also a lot of unregistered software companies operating inside Bangladesh. At least 30,000 professionals work in this industry and this industry earn an approximate of 250 million USD in revenue. In the financial year 2016-17' this sector earned 800 million dollars and it is expected that within 2021 this will rise to a billion dollars.

### **Digital Bangladesh Initiative**

Digital Bangladesh Initiative aims at applying technological advancements to every sector of the country. This initiative requires strong support from the ICT sector. The goal of the Access to Information(a2i) project is to provide information and communication services to the remotest parts of Bangladesh. The project has established offices in every district and Upazila. This enabled the grassroot levels of administrative works in our country a greater access to information while keeping in contact with the central administration system. The management has become a lot stronger with the access to information and access to various government provided services. Every Union parishad office, post offices have Information and Service Centers which are providing digital service to the mass.

### **Agricultural Services**

Agriculture provides us with the lion's share of our economy. Proper use of information and communication technology in the fields of agriculture can result in an impressive growth in our economy. Electronic and digital media are already playing a vital role in disseminating necessary information to the grassroot level farmers so that they can learn about modern farming techniques and such. There are several government and non government apps and websites that answer most frequently asked queries from the farmers. These type of initiatives are already bearing fruit as the production has increased in recent years.

### **Industry and Production**

Garments sector earned 36.67 billion dollars in exporting goods in 2018 alone. With the help of ICT reaching new markets, developing new clients, attracting new buyers, searching for low cost raw materials have never been easier. Ship building, tannery, fisheries, jute and medicine industry also played a great role in the growth of our economy and ICT had a part to play in all of these sectors.

### **Employment**

Once there was a fear among us that the progress of ICT will rob many of their jobs as many of the menial jobs will become automated. But in reality the opposite happened, ICT has produced millions of new jobs and many people are self employed and working as a freelancer from their home because of it. The increasing demand of ICT professionals have positively impacted our unemployment problem too. The world has a demand for 6 million or more ICt professionals right now. We should aim to provide the world with at least 50,000 ICT professionals. Every year we send 10 million people as labourers in foreign countries and they earn 10% of our GDP. If we can train these labourers with the minimum knowledge of ICT, they can earn better and lead a better life at home and abroad.

## Exercise

### MCQ

1. What is more important to the concept of a global village?
  - a. Information
  - b. Software
  - c. Hardware
  - d. Connectivity
2. What is used to create a new sequence of a DNA?
  - a. Genetic Engineering
  - b. Nanotechnology
  - c. Bioinformatics
  - d. Biometrics
3. What type of images are used in virtual reality?
  - a. One dimensional
  - b. Two dimensional
  - c. Three dimensional
  - d. Multi dimensional
4. Which tasks are robots used for?
  - a. Taking administrative decision
  - b. To replace humans in risky situations
  - c. To increase the workload of humans
  - d. To take freely complex decisions
5. What are the usage of Tele presence?
  - a. Cryosurgery
  - b. Artificial Intelligence
  - c. Biometrics
  - d. Virtual Reality
6. Biometrics are used in-
  - i. to ensure the safety of a home
  - ii. to ensure the attendance of students
  - iii. to detect criminal activities.

Which of these statements are true?

a) i and ii    b) i and iii    c) ii and iii    d) i, ii and iii

**Read the following passage and answer the questions no 7 & 8:**

Four friends work as professionals in four different companies. One of them has to gain access to his office by placing his palm into a machine. One of them has to place his face in front of a camera for a few moments to gain access. Both claim that their office has the best system to ensure security and employee attendance.

7. Which technology is used for access control in the offices?
  - a. Virtual Reality
  - b. Biometrics
  - c. Bioinformatics
  - d. Nanotechnology
8. Among the technology mentioned in the passage, which one is more accurate and precise?
  - a. Fingerprint
  - b. Hand geometry
  - c. Iris and retina scan
  - d. Facial recognition

**Read the following passage and answer the questions no 9 & 10:**

Applying new technology for researching high yielding rice breeds, Bangladesh has become self-sufficient in food supply. In fact, Bangladesh has started exporting rice to other countries.

9. What is the new technology mentioned here?
- Genetic Engineering
  - Bioinformatics
  - Biometrics
  - Nanotechnology
10. The activity mentioned in the passage will have -
- Negative impact of land fertility
  - Improve economical condition
  - Created Biodiversity
- Which is true?
- a) i and ii    b) i and iii    c) ii and iii    d) i, ii and iii

**Read the following passage and answer the questions no 11 & 12:**

In this era of modern technology, Shawkat is getting his driver's training from home. His father is using another technology to breed flowers.

11. What technology is Shawkat using?
- Virtual reality
  - E-commerce
  - E-learning
  - Artificial Intelligence
12. What is the downside of the technology that Shawkat's father is using?
- Local breeds will be lost
  - The production can be hampered
  - New diseases can be created
- Which one is true?
- a) i and ii    b) i and iii    c) ii and iii    d) i, ii and iii

**Creative Questions**

1. Biplobi and Keya are both continuing their Higher Secondary Education. Their ICT teacher gave them an assignment to create a report on 'Usage of Traffic Technologies in Dhaka that are used in clean cities of the world. Biplobi made his assignment by reading books from the college library and collecting information from the internet. All of the information in his assignment has references. While Keya copied his assignment from a University student that he found on the internet. The ICT teacher immediately detected that Keya's assignment was plagiarised.
- What is virtual reality?
  - Fundamental research can not be conducted with artificial intelligence - explain.
  - Explain how Biplobi used modern technologies for making his assignment.
  - Describe the negative impact of technology from what Keya has done.

2. Mumtah just watched a movie on her new television. She found out if she used a special type of goggles she can experience the feeling of being inside the movie. She asked her father and he told her that the television and the movie was made using a special kind of technology, that is how it was possible. Mumtah shared her experience with her friends with her Facebook account.
- What is robotics?
  - Explain the concept of digital Bangladesh
  - Explain the technology described in the passage
  - Mumtah's experience sharing through Facebook is related to the concept of global village - explain.
3. Dr. Prianka can access his laboratory using his finger. He can access another room inside the laboratory by looking at the sensor. One day he went to a doctor for a surgery to remove a wart. The doctor completed the surgery in a  $-20^{\circ}\text{C}$  environment, which was a bloodless operation. After the surgery he returned to his laboratory and started working again.
- What is video conferencing?
  - How can you get medical services from your home?
  - What technology did the doctor use to perform the surgery?
  - The technologies used in the laboratory are basically the same - explain.
4. Shihab, a researcher, came to his laboratory in the morning and found out that he could not access the laboratory. That was because he cut his finger last night and had a bandage over his index finger. He had to wait until his colleague Shafayet arrived to let him in. Annoyed by this he requested the laboratory authority to use a password based access system.
- What is a robot?
  - Bangladesh is self-sufficient in food production due to the advancement of technology - explain.
  - What technology was used to open the doors of the laboratory? Describe.
  - Is the request Shihab made to the authority logical? Explain.

## Chapter Two

# Communication Systems and Networking

---



**Ground Station of Bangabandhu-1 Satellite**

It goes without saying that in the present world we humans are connected with one another almost like a family. In the past, the world might have overlooked a crime against humanity and the perpetrators would get away with it. But this is not possible anymore. War still exists in this world but we have mitigated most of it. We have technology to thank for it. No country in the world now can start an unnecessary war without answering the conscience of the whole world. Networking has made it possible for the whole world to live like a single family. To create this networking many different technologies work in tandem to create this vast family of conscience. This chapter will discuss some of the technologies that made this into reality.

**After studying the chapter students will be able to**

- Explain the concepts of communication systems
- Comprehend the concepts of data communication
- Explain the process behind data communication
- Classify the data transmission modes
- Compare between different modes of data transmission
- Understand the importance of optical fiber in data communication
- Identify the different mediums used for wireless communication
- Find the difference between data communication systems of different eras
- Know the importance of wireless communication technology in ICT
- Explain the concepts of a network
- Understand the importance of networks
- Explain the usage of different types of networks
- Understand network topology
- Understand the concept of cloud computing
- Know the advantages of cloud computing.

## 2.1 Communication System

### 2.1.1 Concept of Communication System

Communication is a very natural process, humans and even animals and birds communicate with each other. Even before human civilization came to being human beings used different modes of communication among themselves. First they used sign language and then they invented languages for communication. Then with the ages human beings discovered the means to communicate with people in long distances - letters, telegrams, telephones were invented to progress the modes of communication. Radio and television are different types of communication media too where the presenter or anchor communicates with a mass number of audience. This sharing of information and expression is called a communication system. In the current day and age, the internet and cellular technology has progressed the communication system so far that now human beings not only communicate with themselves but they can now communicate with machines too.

So communication has become a medium of imparting or exchanging of information through a person or machine. This process connects the sender and receiver of information through one or more communication media and numeracy machine elements.

### 2.1.2 Concept of Data Communication

Communication is the process of establishing a link between two points for exchanging information. That is, a secure and efficient data exchange between sender and receiver. Figure 2.1 shows the structure of an electronic data communication system.

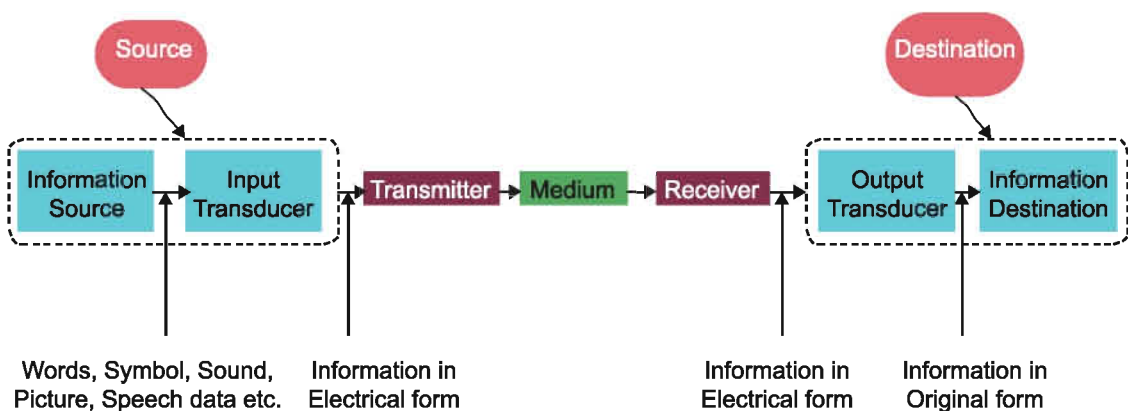

Figure 2.1: Different parts of Data Communication

Here it is seen that using different parts of data communication, words, symbols, waves, pictures etc. from the source reach the destination as a medium. This process requires a transmitter and a receiver. Data from the source is converted to an electric signal (can also be a light signal) via an input transducer and sent to a medium (wire or wireless) through a transmitter. The receiver then converts the electric signal from the medium through the output transducer to the destination. The data source obtained here is like data. It is mentioned that noise (scattered unexpected electric signals) may be added to the medium while transmitting data from the source to the destination which has a system of correction.

Examples of components used in data communication:

1. Source (data source + input transducer) - microphone, camera, keyboard, etc.
2. Transmitter - radio / television station, telephone, mobile phone, modem, router etc.
3. Medium - Telephone / Fiber Optic Cable, Radio / Microwave etc.
4. Receiver or customer device - telephone exchange, modem, router etc.
5. Destination (Output Transducer + Data Destination) - Loudspeaker, Telephone, Computer etc.

### 2.1.3 Bandwidth

As a resident of the present world most of us have a little bit of an idea about internet speeds. This speed of the internet depends on the signal's bandwidth. Bandwidth is a range of frequencies within a given band, in particular that used for transmitting a signal. Essentially it denotes the rate of data transfer. Bandwidth is usually calculated in bits per second(bps) units. But as the internet and communication medium improved now the bandwidth is calculated in kbps(1000 bits per second), Mbps(1,000,000 bits per second) or even Gbps(1,000,000,000 bits per second). A Byte consists of 8 bits. So 1MBps is equal to 8Mbps.

**Table 2.1:** Bandwidth needed for different services

Internet	0.5 Mbps
Web Browsing	0.5 to 1.0 Mbps
Streaming Music	0.5 Mbps
Voice Call(VoIP)	0.5 Mbps
Streaming Video	0.7 Mbps
Streaming Movies	1.5 Mbps
Streaming HD Movies	4 Mbps
Video Conferencing	1 Mbps
HD Video Conferencing	4 Mbps
Internet Gaming Console	1 Mbps
HD Online Multiplayer Gaming	4 Mbps

The bandwidth of a communication network depends on the communication medium and the equipment used in the network. For example an optical fiber cable can provide you with much more bandwidth than a telephone cable. But if you do not use the proper terminal equipment in conjunction with the optical fiber, you won't get the desired bandwidth.



As a communication network is used by many users, the network bandwidth is usually shared among the users. Sometimes a user or a service can forcibly use a larger share of the bandwidth by themselves limiting the bandwidth to the rest of the users. There are many systems available to measure the actual bandwidth an average user is getting. There are tools and systems to detect problems and faults in network design or problems with network equipment. Overall, bandwidth management is a very challenging task.

The 2.1 table shows the necessary minimum bandwidth required for certain services. If a user doesn't get the proper bandwidth for his services, he won't get the right results or experience from those services.

### 2.1.4 Data Transmission Methods

Data transmission refers to the process of transferring data between two or more digital devices. It depends on the distribution of bits.

Data transmission methods can be divided into two types - parallel and serial data transmission, depending on the bit distribution. Serial data transmission sends one bit at a time into one medium, whereas parallel transmission method uses multiple mediums to send multiple bits at a time.

#### Parallel Data Transmission

When data is sent using parallel data transmission, multiple data bits are transmitted over multiple channels at the same time. In this method one or two control lines are used alongside data lines to synchronise the transmitter and receiver. As the data is processed parallelly inside the computer circuits, this is the more natural way to transmit data. This is obviously the faster way of transmitting data as it sends multiple bits over multiple channels at a time. But this is not the ideal way if you want long distance data transmission. Video streaming usually uses this transmission method. Printers along with parallel ports and cable use this transmission method too.

#### Serial Data Transmission:

When data is sent or received using serial data transmission, the data bits are organized in a specific order, since they can only be sent one after another. The order of the data bits is important as it dictates how the transmission is organized when it is

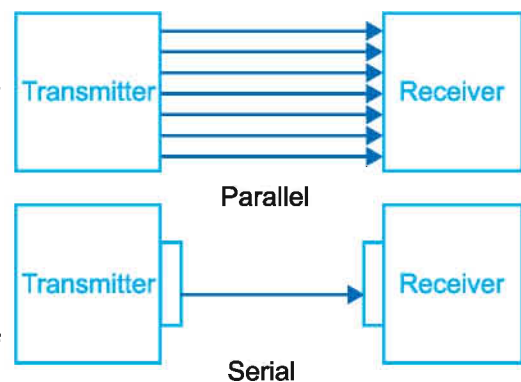

Figure 2.2: Parallel and Serial Data Communication

received. It is viewed as a reliable data transmission method because a data bit is only sent if the previous data bit has already been received. This transmission method is less noisy as there is only a single channel for data transmission. The popular Universal Serial Bus or USB port uses serial data transmission methods.

**Bit Synchronization**

When using serial data transmission both the transmitter and receiver use a clock to synchronize bits. A bit is transmitted and received with each pulse of the clock. Bit synchronization is a technique that determines the beginning and ending of a bit with the clock. With this a receiver can identify and recover data.

Depending on bit synchronization the serial data transmission can be classified into three types:

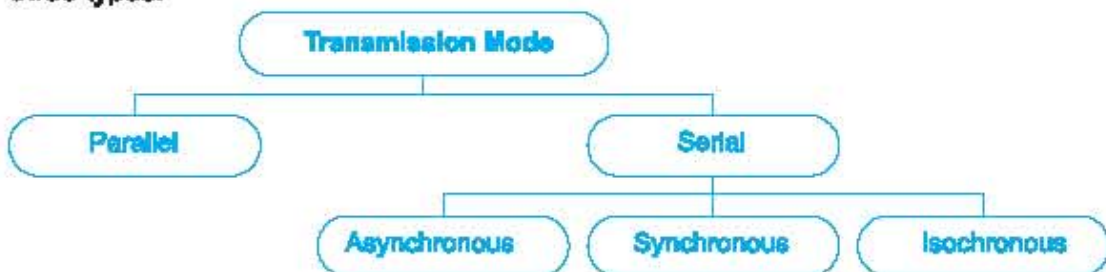
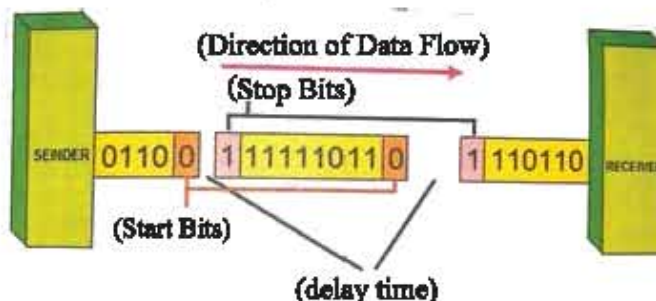

Figure 2.3: 3 Types of Data Communication

1. Asynchronous Transmission
2. Synchronous Transmission &
3. Isochronous Transmission

**Asynchronous Transmission**

In asynchronous transmission the transmitter can send the data whenever it wants and the receiver is always prepared to receive data. The transmitter can even spend as much time it wants between two data transmissions. Prior to sending data the transmitter sends a starting bit from which the receiver knows that the transmission has started. At the end of transmission one or two stop bit is sent so the receiver can know the transmission is ended. As in this technique a transmitter can send data anytime it does not need a primary storage device like RAM, Cache or CPU memory. This technique is useful when sending small amounts of data at a slower speed.



Computer keyboard uses asynchronous data transmission. As there can be an undetermined amount of time between two key presses, asynchronous transmission is used here.

### Synchronous Transmission

Synchronous data transmission is a continuous process. With this technique a transmitter sends data to a receiver continuously until the transmission ends. In synchronous data transmissions, the receiver station divides the data characters into blocks or frames and stores them into a primary storage like RAM, Cache or CPU memory. Each block or frame is synchronized with the clock to transmit them with equal delays. At the beginning of each block 1 or 2 bytes are reserved for header information and at the end of the block 1 or 2 bytes are reserved for trailer information signals. Header and trailer bytes usually contain addresses or identification numbers to properly locate transmitter and receiver inside a network. Header signal is used by the receiver machine to synchronize its clock with the transmitter. Trailer signal denotes the end of a block and sometimes contains information for error correction in transmitted data.

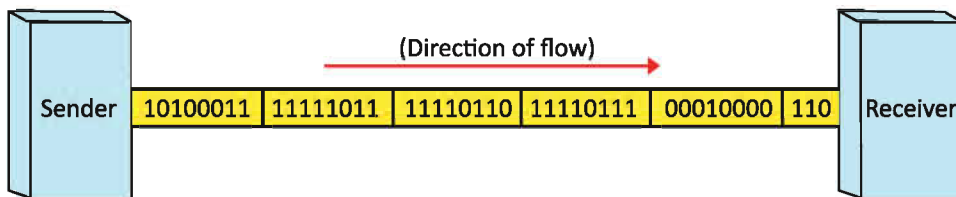

Although this is a more complex and costly process, synchronous data transmission is usually used to transmit data over long distances using a larger bandwidth. Larger networks like cellular networks and TV networks use this transmission technique.

### Isochronous Transmission

Isochronous transmission is a cross between Synchronous and asynchronous transmission. This process uses the start and stop bits of asynchronous transmission but transmits data in blocks like synchronous transmissions. As this is not totally synchronous so primary storage devices are not needed. Real time applications such as multimedia communications, audio and video calls use this particular technique.

## 2.1.5 Data Transmission Mode

Data transmission mode or data communication mode refers to the mechanism which denotes the direction of the flow of information between two devices. It can be of three types:

**Simplex Mode**

In this mode the transmission flow is one directional. Transmitter only sends data and the receiver only receives data. Keyboard, mouse, joystick are examples of simplex communication mode.

**Half Duplex Mode**

In this mode, data transmission can be directional but not at the same time. When one device is transmitting data the other has to wait for its chance. There are provisions for special circuits to avoid data collisions. Walkie Talkie, fax, SMS are operated in half duplex mode.

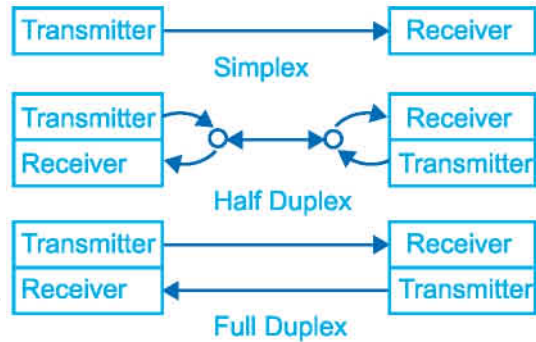

Figure 2.4: Simplex, Half Duplex and Full Duplex Modes

**Full Duplex Mode**

In this mode both devices can simultaneously transmit and receive data. Telephones, cellular networks, computer network communication are examples of full duplex mode communication.

**Data Distribution Mode**

Depending on the number of receivers and the access to data, data distribution mode of several forms:

**Unicast Mode**

In this mode one transmitter communicates with just one receiver. Unicast mode can be of simplex, half duplex or full duplex mode. Joystick, fax, walkie talkie, SMS are examples of unicast mode.

**Broadcast Mode**

In this mode there is only a single transmitter but any receiver within the transmission network can receive the data. Broadcast mode can only be simplex. Radio, televisions are examples of broadcast mode.

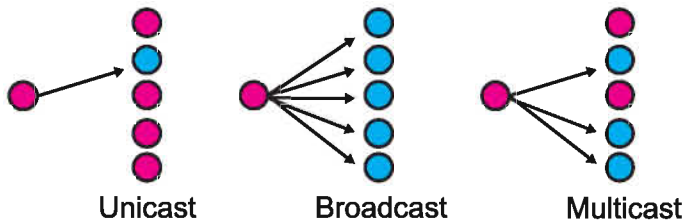

Figure 2.5: Unicast, Broadcast and Multicast Modes

## Multicast Mode

Multicast mode is similar to broadcast mode as there is only a single transmitter and multiple receivers. But only the receivers who are granted access can receive the data. Multicast mode operates in either half duplex or full duplex mode. Video conferencing, chatting are examples of multicast mode.

## Medium of Data Communication

The channels used to exchange data between a transmitter and receiver are known as data communication mediums. There are multiple types of mediums to construct this data communication channels. The wired and wireless mediums used to receive data transmission from radio, TV or cable TV communications are mediums. Figure 2.6 denotes different data communication mediums.

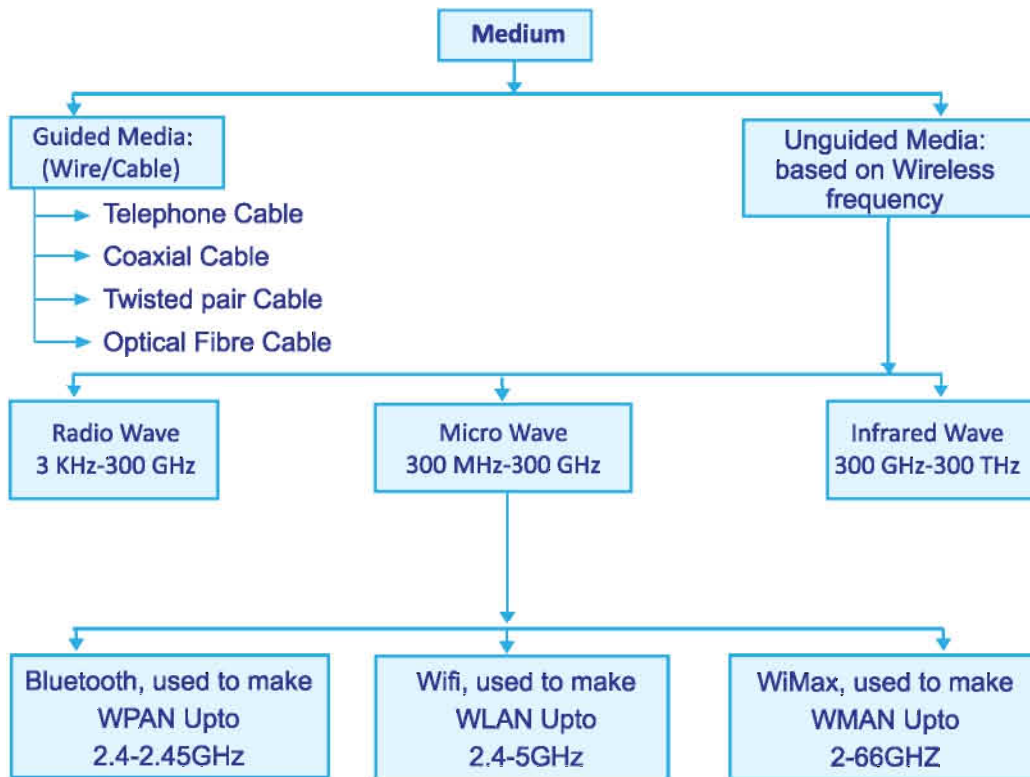

Figure 2.6: Different mediums for Data Communication

### 2.2.1 Wired cable medium

Copper or Aluminum cables are used as medium in this process. The cable guided media can have many different types of cable. Some of the variations are explained here:

### Twisted pair cable

A pair of conductive wires are twisted to make the twisted pair cable. Twisted Pair Cables can be of two types - Unshielded Twisted Pair Cable and Shielded Twisted Pair cable.



**Figure 2.7: Unshielded and Shielded Twisted pair Cables**

Generally these wires are made from copper and four pairs of wires are separated with an insulator. Each pair has a wire in a common colour (white) and the other one of a different colour (brown, green, blue or orange). These cables can be used to transmit data upto a distance of 100 meters. Depending on the category the bandwidth of the cables can be from 10Mbps to 1Gbps. Data transfer rates start to drop off with the increase of distance. Twisted pair cables are generally used in educational institutions, corporations and homes.

### Coaxial Cable

Coaxial cables are copper made cables that have three layers inside. At the center there is a rigid copper conductor, outside of that there is a layer of plastic insulator and outside of that there is a braided shield made of copper. There can be a metallic foil between the insulator and braided shield layers. At the outside a thick rubber layer covers the cable. The braided copper shield and the metallic foil together act as an outer conductor and protect the wire from external electromagnetic disturbances. As the outer shield and the central copper conductor share the same axis so it is called a coaxial cable. Compared to twisted pair cables, coaxial cables provide a better data transfer rate and a reduced data transmission loss. Both digital and analog data can be transmitted through these cables. These types of cables are particularly used in scientific research laboratories and in cable TV networking. Coaxial cables can be of two types - thinnet and thicknet.



**Figure 2.8: Coaxial Cable**

**Thinnet:** Thinnet is a lightweight and flexible wire. This is also known as 10BASE-2. This cable can transmit data upto a distance of 185 meters at a rate of 10Mbps without using any repeaters. Repeater is one kind of device that can amplify the weak signal into strong signal.

### Thicknet

Thicknet cables are heavy and non flexible. This is known as 10BASE-5. This cable can easily transmit data upto a distance of 500 meters.

### Fiber Optic Cable

A fiber-optic cable, also known as an optical-fiber cable, is an assembly similar to an electrical cable, but containing one or more glass made fibers that are used to carry light. The optical fiber elements are typically individually coated with plastic layers and contained in a protective tube suitable for the environment where the cable will be deployed. A special characteristic of optical fiber cables is, it is incredibly transparent to a range of infrared lights(1300nm-1500nm). So without much risk of absorption we can send signals to a long distance.

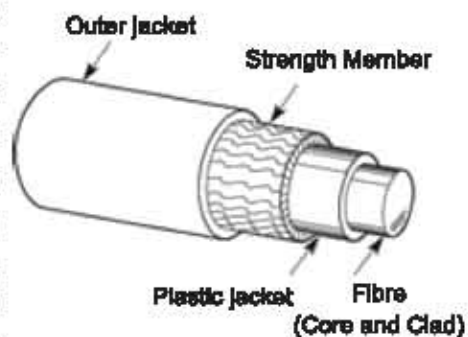

**Figure 2.9: Structure of an Optical Fibre Cable**

The refraction index of the central layer of the optical fiber cable is higher than the outer layer. The part where the refraction index is the highest is called the core. The part where the refraction index is the lowest is known as Clad. This difference in the refraction index makes the light travel through the cable with the principles of total internal reflection. Although light captured inside the core is a little different than the usual total internal reflection phenomenon. The glass made optical fiber is very fragile so they are covered in a plastic outer layer while they are being manufactured. Finally, they are covered with a polymer and kevlar layers for protection.

### Single Mode and Multi Mode Fiber

An optical fiber has a diameter of 150 micron. The diameter of the core can be from 4 microns to 100 microns. If the core diameter is between 8 and 12 microns, is called single mode fiber. Because then only a single mode of data can be transmitted through the fiber. Single mode fibers are used for long distance high speed transmissions. Due to the small diameter of the core, these types of cables are more expensive.

If the core diameter is between 50 to 100 microns, there can be multiple modes of transmission. As the different modes transmit differently there can be distortions in the signal. So this cable is only used in small distance slow speed transmissions. This technology is less costly and easily available due to the larger diameter of the core.

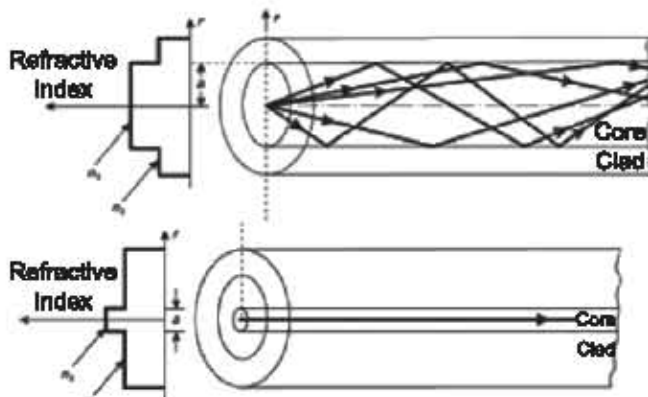

Figure 2.10: Multi Mode and Single Mode Fibre

### Laser

To make the fiber optic communication really effective we had to wait for the invention of 1300nm to 1500nm laser. LED lights do not have a fixed wavelength so due to dispersion of light there can be signal distortions. So it is not suitable for long distance communications. Laser light has a fixed wavelength so it is preferable for long distance optical fiber communications.

Although we can use any wavelengths of lasers between 1300nm to 1500nm in optical fiber communication, the invention of fiber amplifiers for 1500nm laser has made this wavelength of laser used widely for long distance communications.

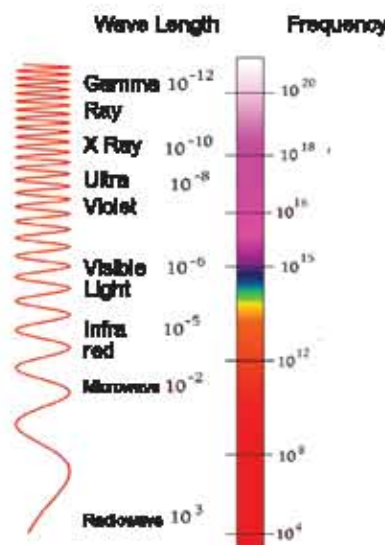

Figure 2.11: Spectrum of Electromagnetic waves

### 2.2.2 Wireless Media

Exchange of information between two devices can be possible through electromagnetic waves, no wires are needed in this case. This is known as wireless media.

Figure 2.11 shows the spectrum of electromagnetic waves. The higher the frequency of a wave the smaller its wavelengths are. Two portions of this electromagnetic spectrum have played key roles in modern communication - radio waves and microwave.



### Radio wave

Generally radio waves are classified as having frequencies between 3KHz and 300GHz in the electromagnetic spectrum. But with respect to communication generally 10KHz to 1GHz(30Km to 30cm wavelength) waves are widely used as radio wave communication.

If the wavelength is bigger, the electromagnetic signals are dispersed more widely. So radio waves are more commonly used for broadcasting. The antenna used to transmit the signal has to be one fourth of the length of the signals wavelength. That is why low frequency waves are not very realistic. Radio waves are not absorbed much in the environment and it can penetrate obstacles due to its wide wavelength. Radio waves are reflected in the ionosphere so one can transmit a signal from one part of the earth to the other, This is why radio waves are widely used as communication media.

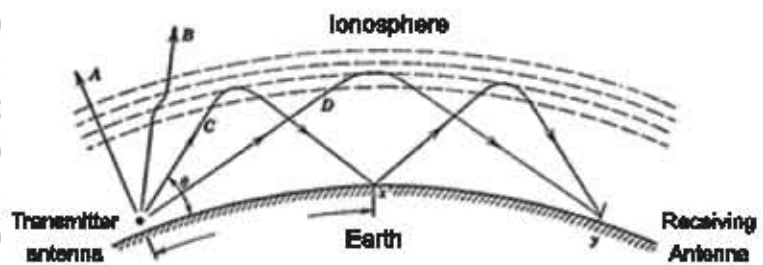

**Figure 2.12: Transmission of radio waves on the earth surface**

### Microwave

Generally microwaves are classified as having frequencies between 300 MHz and 300 GHz in the electromagnetic spectrum. But with respect to communication generally 1 GHz to 100 GHz frequency are widely used as microwave communication. It does not disperse like the radio waves but follows a single direction. This is why the transmitter and the receiver antenna have to face each other and the connection has to maintain LOS or Line of Sight. Microwave system mainly consists of two transceivers, one for transmitting signals and other for receiving.

There are two types of microwave communications-

1. Terrestrial
2. Satellite

#### Terrestrial

Terrestrial Transmitters are usually placed in places where cable connections are not accessible. Microwave transmissions can not go through if there are large obstacles between receiver and transmitter. There must be a clear line of sight between the transmitter



**Figure 2.13: Example of a Terrestrial Transmission**

tower and the receiver. This is why generally transmitters are placed above high rise buildings, mountain tops or on high towers. Due to the uneven topography of the land and natural obstacles there is a relay or repeater station placed after every 40 or 50 kilometers.

### Satellite:

As microwaves can penetrate the ionosphere level of the atmosphere of earth, artificial satellites use microwaves to maintain ground communications. When a satellite is placed 36000 kilometers (approx) above ground level it circles the earth at the same speed of its rotation, that is why these types of satellites are called

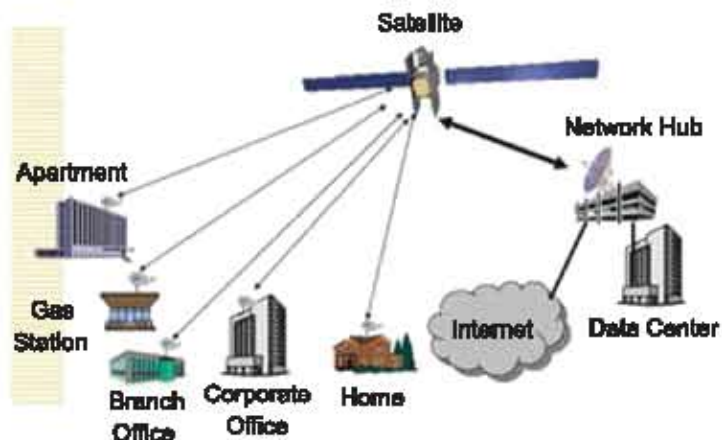

Figure 2.14: Example of Satellite transmission

geostationary satellites. From the ground the satellites seem fixed at a point in the sky. The VSAT or Very Small Aperture Terminal is placed to face the satellite's position in the sky. Bangabandhu-1 is a geostationary satellite and the ground stations have their receiving antennas fixed on a particular point in the sky where the satellite is located. Worldwide cable TV services, emergency communication of the defence system and weather updates are communicated by the satellites through microwave technology.

## 2.3 Wireless Communication System

### 2.3.1 Necessity of Wireless Communication System

Making the telephone communication wireless was a huge achievement of modern communication technology. Once the telephone was only used to speak with people at a long distance. Now we can exchange text messages and use the internet through our smartphones which has opened many new doors of possibilities for us. Smartphones have become just as essential to our day to day lives as once the telephone was. We can not think of a world now without wireless communication technology. It serves our individual needs like communication with friends and family, entertainment, education, health care also serves the needs of our nation like emergency response, defense system, maintaining law and order, disseminating and collecting important information, research work and such.

Keeping constant communication with aircrafts, sea vehicles and even space crafts, only wireless communication technology makes it possible. Wireless technology has increased our productivity in various sectors like business, healthcare, education and many more. Tracking a criminal or a traveler is only possible through this technology. Solving administration issues at the remotest parts of the countries through video conferencing is possible through wireless communication technology.

The rise and advancement of wireless communication technology with the Internet have given birth to possibilities that we only dreamt of. One of these modern inventions is IOT or the Internet of Things where electronic devices, softwares, sensors, home appliances, actuators and other devices are connected through a network so they can be operated with a central command system and can exchange information among themselves. Home automation, supply chains, agricultural operations, manufacturing processes, healthcare and many other sectors are reaping huge benefits with the help of IOT technology. People now use smart wristbands while exercising that can send your pulse rates, walking speeds and other health related information to your smartphone so you can monitor your own health conditions. These are all IOT devices.

### 2.3.2 Bluetooth

Bluetooth is a technology that can communicate wirelessly between two devices in a short distance. Bluetooth networks have less bandwidth and security than other wireless technology but it is still very popular. The devices that have this technology are called bluetooth devices. Laptops, smartphones, tablet PCs, PDAs now have built in bluetooth technology inside them. Mouse, keyboard, headphones, speakers with bluetooth abilities are becoming more and more popular nowadays.

The bluetooth network is a Personal Area Network or a PAN which works in 2.45GHz frequency and has a range of 3-10 meters. It has a transmission rate of about 1mbps in half duplex mode. It is easy to install and automatically configurable. A bluetooth network is also known as piconet. A piconet can contain a maximum of 8 devices, one of them acts as the master device and others as slave devices. Multiple piconets can form a network called scatternet.



Figure 2.15: Bluetooth Logo

### 2.3.3 Wi-Fi

Although there was no official announcement, the word Wi-fi which is the short form of Wireless Fidelity has been adopted by the whole world at some point. The word is trademarked by an organization called Wi-fi Alliance. Wi-fi is a very popular wireless technology of the present that is mainly used to create high speed Internet networks and local area networks to exchange data between devices at a very fast transmission rate.



Figure 2.16: Wifi logo and icon

You do not need any licence or approval to use the wi-fi network and a wi-fi device can work with any other wi-fi device of the world, so there is an obvious issue of security here. This network usually operates between 2.4GHz to 5GHz frequency and the coverage area spans from 50 to 200 meters. The easy availability and connectivity of this technology has made it vulnerable to many security risks and privacy related issues.

### 2.3.4 WiMax

Wimax is a high speed wireless communication technology that is being used widely instead of the regular Digital Subscriber Line connections for Internet services. WiMax is the short form of Worldwide Interoperability for Microwave Access.

This technology operates between 2GHz and 66GHz range and can transmit data at the rate of 80Mbps to 1Gbps.

**Wimax has two components:**

Base station consists of indoor devices and outdoor towers. Each base station has a coverage area of 50 to 80 kilometers.

Wimax receiver with antenna that can be connected to computers and laptops and is portable.



Figure 2.17: WiMax logo

With this technology thousands of clients can be provided with Internet services in a wide geographic area with just one base station. As this technology is wireless and easily portable, this is more convenient to provide internet connections to remote areas.

Unlike Wi-Fi, the use and installment of WiMax networks need approval from the authority. This network is costly to install and maintain as it can cover a wide range of areas and connect many more clients than the other available technologies.

**Table 2.2**

Name	Bluetooth	Wi-Fi	WiMax
Standard(IEEE)	802.15	802.11	802.16
Frequency (GHz)	2.45	2.4-5	2-66
Speed (Mbps)	0.72-25	11-200	80-1000 (1Gbps)
Range (Meter)	3-10	50-100	10000-50000 (50 km)
Network	WPAN	WLAN	WMAN

## 2.4 Mobile Communication

Wireless communication between mobile or stationary devices at a distance is called mobile communication. Mobile phones are household things nowadays all around the world. To establish a mobile or cellular network, an area is divided into multiple cells or zones and each cell has a base station of its own. When a user makes a call to another user, the call is connected to a switching station through the user's base station. The switching station determines the receiving base station of the person who will receive the call.

The call is then dispatched to the receiver's cellular base station and the base station connects the call with the intended receiver. The mobile phone set functions both as a wireless transmitter and a receiver. As it works between different cells this is called a cellular technology and the phones are called cellular phones or cellphones in short.

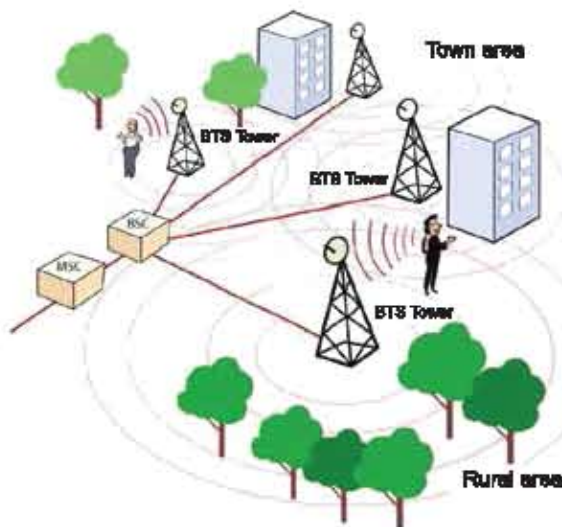

**Figure 2.18: Mobile communication**

At the beginning cellphones were only used to make voice calls. But now we can do all sorts of things using our phones. Everything you can do with a computer or laptop can also be done with a cell phone nowadays.

### 2.4.1 Different Generations of Mobile Phones

Mobile phones of today have very little similarities with mobile phones in the past. Different technological evolutions over the years brought the mobile phones to their current look and feel. Each big leap in technology that changed mobile phones are known as generations of mobile phones. Mobile phones were first used by the US military in 1940, during the second world war. It had very limited capacity and a very short coverage area due to the weak network system. Asia's largest telecommunication company Nippon Telegraph and Telephone Corporation situated in Japan began commercially manufacturing mobile phones in the 80s. The commercially manufactured mobile phones can be divided into 5 generations.

#### First generation, 1G: 1979 - 1990

The technological revolution sparked a huge change in the mobile phone industry first and foremost. Motorola DynaTAC was the first handheld mobile phone manufactured and used in the United States. At the same time, Advanced Mobile Phone System or AMPS announces the first generation of mobile phone standards. Around the same time the United Kingdom started using Total Access

Communication System or TACS that used semiconductors and microprocessors in mobile phones which operated in low band frequencies. This is why at that time you could not make a call to other providers networks and there was limited roaming capacity.



Figure 2.18: First generation mobile phones

### Second Generation - 2G: 1991-2000

Replacing analog transmissions with digital transmissions signalled the beginning of the second generation of mobile phones. That is why a second generation or 2G network is also known as digital cellular network. The second generation mobile phones had two new features - Global System for Mobile Communication or GSM



Figure 2.20: Second Generation mobile phones

and Code Division Multiple Access or CDMA. This is why the 2G mobile phones are marked with GSM/CDMA standards. This new technology made the calls more noiseless and crisp. 2G also ushered the time of SMS, MMS and mobile internet. International roaming calls started.

### Third Generation - 3G: 2001-2008

A Japanese company named DoComo started experimental manufacturing of third generation mobile phones. Third generation of mobile phones replaced the previous circuit switching data transmission system with the new packet switching data transmission methods. In circuit switching method the networking resources or bandwidth are divided into data packets which then travel to the destination following a particular path, which is vulnerable security wise.



Figure 2.21: Third Generation mobile phones

But the packet switching methods divide the networking resources or bandwidths into packets but transmits them through different paths, making the transmission more secure and reliable. In the third generation, higher band frequency signals were being used, data transfer rate increased upto 2mbps. Third generation of mobile phones brought forth 4 new standards:

1. HSPA: High Speed Package Access
2. WCDMA: Wideband Code Division Multiple Access
3. 3GPP: 3rd Gen Partnership Project
4. UMTS: Universal Mobile Telecommunication System

Video calls, high speed internet, e-commerce, mobile banking and freedom of multimedia access were the main outcomes of the third generation of mobile phones.

#### Fourth Generation - 4G: 2009-2020

Fourth generation of mobile phones replaced the packet switching data transmission method with internet protocol based network transmission. This enabled networks like LAN, WAN, VoIP and Internet to use protocol based data transfer methods instead of packet data transmission. Mobile devices can get data transfer rates upto



Figure 2.22: Fourth Generation mobile phones

100mbps, while stationary devices can enjoy up to Gbps of data transfer rates. Fourth generation mobile phones operate in Long Term Evolution or LTE standards. Mobile Web Access, IP Telephony, gaming Services, HD mobile streaming, video conferencing and 3D TV these services rely on 4G technology. 4G is at least fifty times faster than 3G.

#### Fifth generation - 5G; 2020-

The fifth generation of mobile phones will contain the latest mobile phone networking system which is being called the World Wide Wireless Web or WWW. Among the fifth generation mobile phone standards - 5G NR(New Radio Technology), RAT(Radio Access Technology), MIMO(Multiple Input Multiple Output) are gaining popularity. This generation will have transfer rates that are multiple times faster than the 4G technology. With this people will be able to enjoy 4k TV and streaming through their mobile network and devices.



Figure 2.23: Fifth Generation mobile phones



The mobile phone companies are racing against time to bring the changes about the mobile technology even faster. At present mobile phone 5G technology is a reality. It has been introduced in many countries of the world. In our country too it is going to be started.

## 2.5 Computer networking

---

Almost all of us are familiar with the term networking. In business, politics or sales you need proper communication with your clients and potential investors thus creating a network. Likewise, the communication and data transfer methods of two or more computing devices is jointly called computer networking. There are some sets of media and network devices needed to create a computer network.

### 2.5.1 Concept of Networking

We create networks among ourselves to make our daily lives easier, to socialize and to rely on other people when we alone can not make it. The evolution of information technology has enhanced and spread our networking abilities to a completely new dimension. Now we communicate through mobile phones and computers, via text messages, voice and video calls. We use wireless modes of connections while exchanging information between computer devices. So a computer network means a set of interconnected computer devices, bound by geographical boundaries and the process they use to communicate between each other. Using a computer network we can make bank transactions, send emails, receive government services and so on. Even if a computer in the network becomes unusable, another device in the network can provide support for it. A printer connected to a computer network can be used from every device on the network. Thus, the network makes the maximum use of every device present in the system.

### 2.5.2 Objectives of Computer Networking

The purpose of establishing a network between two or more devices is to share resources and communicate securely. A resource is an element or service in a network that is provided by some of the components of the network. Resource sharing between computers removes the limitations of data storage, data processing and makes every task faster and more effective. In short, resource sharing means -

**Information Resource Sharing:** The Internet is the best example of sharing information resources through a network. Locally connected computers can also share their internal information with LAN softwares.

**Software Resource Sharing:** Software resources can be shared via a computer network. Using this, only one software license can be bought and shared among the devices of the network so that every device of the network can use the software. In banking we see everyone using different computer terminals, but actually they are using the same software suits through networking.

**Hardware Resource Sharing:** We see offices, cyber cafes, banks and other organizations use network printers, where all the devices in the network can send print commands to one single printer. This is a really cost effective solution for any organization and makes the best use out of the device.

### 2.5.3 Types of networking

Boundless and unlimited supply of information is a basic need for the modern concept of globalization. To prioritize this concept of information exchange, the whole world has set up innumerable computer networks of different size and topography. These networks use a multitude of different network devices.

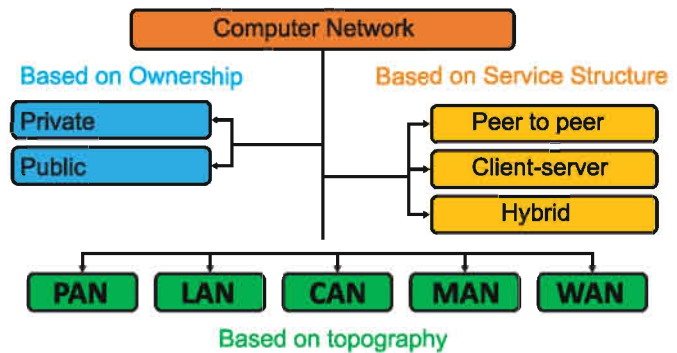

Figure 2.24: Types of Networks

Depending on the devices used or the topography, computer network can be classified according to the following criterions -

- Topography of the network
- Service structure and management of the network
- Ownership of the network

#### Topography of the Network

Depending on the geographical location of the devices inside a network, computer networks can be classified into five types -

1. Personal Area Network
2. Local Area network
3. Campus Area Network
4. Metropolitan Area Network
5. Wide Area Network

- 1. Personal Area Network:** This refers to the home network an individual person builds around his computer device, connecting printers, routers, phones, cameras and computers inside his/her home. The span of a PAN coverage can be 10 metres.



Figure 2.25: PAN

- 2. Local Area Network:** LAN is the most used network in our day to day lives. Offices, businesses, educational institutions use this type of networking to connect all the computers inside a building or one or more floors of the building. Using routers and repeaters the range of a LAN can be increased to a maximum of 1 kilometer. LAN can be of BUS, Star, Tree or Ring Topology. Twisted pair cables, coaxial cables, fiber optic cable or wireless media are used to create this type of network.



Figure 2.26: LAN

- 3. Campus Area Network:** CAN is made of multiple LANs in an area. Generally inside a wide educational institution area like a University uses CAN to connect their different buildings LAN systems. CAN can have a coverage range of between 1 to 5 kilometers. Large office complexes also use CANs to synchronize between devices inside their network of buildings.

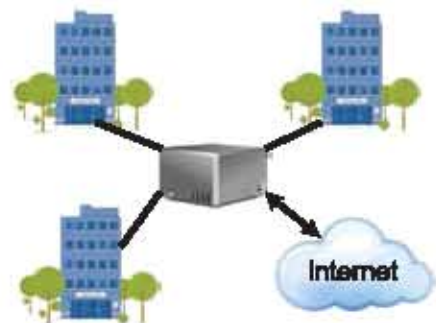

Figure 2.27: CAN

**4. Metropolitan Area Network:** A MAN connects the computer devices inside an urban or metropolitan area. MAN is bigger than a LAN but smaller than a WAN. MAN can have a coverage area of upto 50 kilometers. If the devices inside a MAN are connected via wireless media, it is called a WMAN or Wireless Metropolitan Area Network. Phone Lines, Optical Fiber Cable, Radio Waves or terrestrial microwaves are used as transmission media inside a MAN. Routers, switches, hubs, bridges and gateways are used as network devices.



Figure 2.28: MAN

**5. Wide Area Network:** WAN connects different geographical areas networks into one. The internet is the prime example of a WAN.

#### Service and Management Structure

Depending on how the devices inside a network are managed and their service models, computer network can be classified into the following categories -

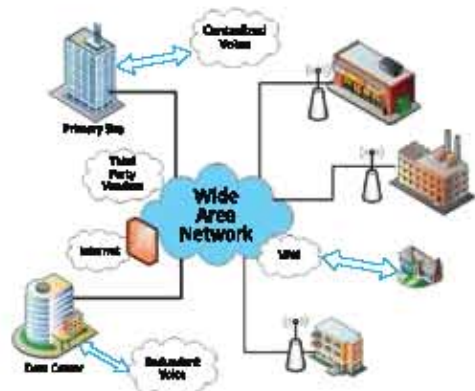

Figure 2.29: WAN

- 1. Peer to Peer Network:** Peer to peer network works without any central servers. Two or more computer devices are connected in the network and they can share information and resources between each other.
- 2. Client-Server Network:** This network contains two or more client stations and a centralised server station. The server computer stores the data of the network centrally and the data resources are shared between the client stations in the network. This is also called a server based network. Depending on the storage media, number of host and terminal nodes client-server networks can be of two types -

- a. Centralised Network: In this system only one centralised server is present is the server which is called the host. The host computer connects with multiple terminals.
- b. Distributed Network: This type of network connects multiple workstations or terminals, shared storage devices and I/O devices.

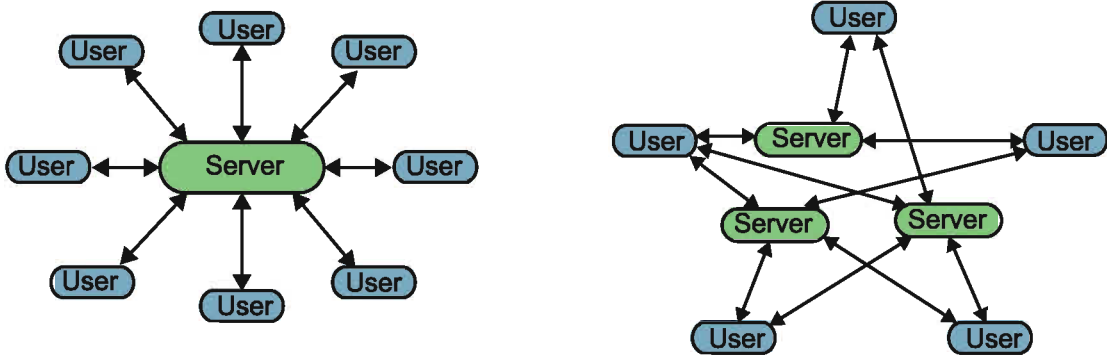

Figure 2.30: Centralised and Distributed Network

3. Hybrid Network: This type of network is a combination of peer to peer and client-server networks. In this system a host computer manages the network while it has the characteristics of a distributed network like shared storage media. This type of network is popular in corporate organizations. A hybrid network prioritises client servers.

### Ownership of Network

Computer networks can be classified into two types depending on the ownership of the network and access and management systems.

1. Public Network: Public network does not have a restriction on network users so any computer device can join or leave the network at any time. This type of network usually is not owned by a particular individual or a company, rather it has the ownership of multiple parties. The users have to pay a certain fee for using this type of network. WAN or the internet is a good example of a public network.
2. Private Network: In private networks the number of users in the network is restricted and defined. Any new users wishing to join the network needs access permission from the network administrator. These types of networks are usually owned by an individual or a company. It has a better security system and less traffic than a public network. PAN < LAN or CANs are private networks.

## 2.5.4 Network Devices

The devices which are needed to construct and install a computer network are known as network devices. These devices work to transmit and receive the data, provide security and manage the flow and direction of the data flow. Some of the Important network devices are -

- **Modem:** Modems were invented before computer networks came about. They were used for creating telephone and television networks. The word Modem is the short form of Modulation and Demodulation. As we can guess from the name, this device converts analog signals to digital and vice versa. With the advent of optical fibers and wireless communication Modem has become almost obsolete.
- **Hub:** Hubs were used to connect a computer device to others in a network. If multiple computer devices are connected with wires in a hub, it will create a LAN. Hubs have no processing abilities. Hubs just broadcast a signal sent to the hub without any kind of alterations. For peer to peer communications all other devices except the destination devices refrain from receiving the signals. Hub does not have a collision protection system or data traffic management system. Hubs are also almost obsolete in the present world.
- **Switch:** Switches have replaced Hubs in computer networking systems. The switches perform the same tasks as a hub but it has processing powers and ability. Switch does not broadcast a signal it uses Media Access Control or MAC address of a computer to uniquely identify it inside the switch and transmit the data to that particular device port, thus avoiding collision. It can also amplify weak signals. Switches can have 8,16,24 or 48 ports. Switches can be used to filter data but the process is a bit complex. Switches are used to create LANs but it cannot create multiple LANs.
- **Router:** A router is a connecting device that can connect two or more networks with the same protocol and extend a network's coverage. Routers can connect multiple LANs to create a WAN. Routers use Network Address Translation or NAT to identify a network. Routers can determine the shortest path for a



Figure 2.31: Switch

transmission of data to one device of one network to another device in a different network. Routers can filter data. They can sense an increase of traffic in a network and use a different route to transmit data.

Configuring a router is a bit

complicated. Routers can only connect networks which have the same protocols, it cannot connect networks with different protocols.



Figure 2.32: Router

- **Gateway:** Gateways are used to connect two networks with different protocols. This is a network connectivity device that connects two or more networks irrespective of their protocols. This device is a bit expensive and harder to configure. But gateways and routers can be used to connect innumerable small networks to

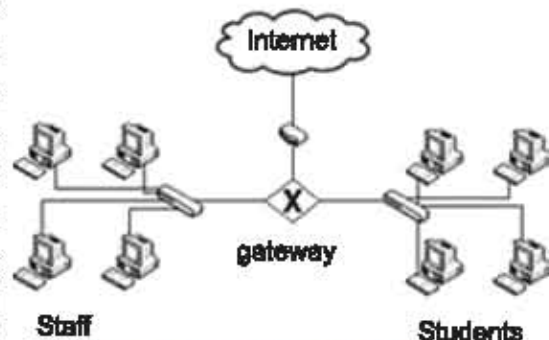

Figure 2.33: Usage of a Gateway

create a huge network. Gateways use Protocol Address Translation or PAT to identify networks. This is why it is also known as a protocol converter. It can filter data and can send data to a target IP address. It is slower than a router but uses better collision avoidance systems.

- **Network Interface Card:** In the recent past, computers needed a separate network interface card to connect it into a computer network. Now all the computers have the NIC built in with the system so it is almost obsolete nowadays.

## 2.5.5 Functions of Network

The main function of a computer network is communication and resource sharing. Functions of network devices inside a network is explained briefly in the following section:

1. Manage data communication between the network devices. Complete resource management.
2. Provide user access control and monitoring
3. Ensure fast and easy availability of information and resources

4. Create fast and effective communication with the world wide network.
5. Use in fields like education, healthcare, financial transactions, office work and many more.
6. Ensure the effectiveness and management of server machines
7. Provide back up data, ensure data safety and access.
8. Ensure the security and privacy of sensitive data.
9. Protect the system from unauthorized access.

### 2.5.6 Network Topology

Network topology refers to the manner in which the links and nodes of a network are arranged to relate to each other. Different network topologies grant different types of advantages to communication and resource sharing mechanisms. A network topology defines the physical connection pattern and how the data communication paths are arranged. A computer network can have devices other than computers. The connecting points of each computer or peripheral devices are called nodes in a network. The following topologies are generally used in computer networking systems;

1. Bus Topology
2. Ring topology
3. Star Topology
4. Tree Topology
5. Mesh topology
6. Hybrid topology

#### Bus Topology:

In this topology there is a central connection line where all the nodes or computer and other devices are connected. This central line is known as the Bus. Buses can be made of fiber optic cables and work as the backbone of a network. Buses have two terminators at each end.

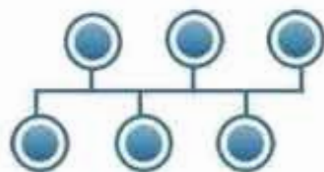

Figure 2.34: Bus topology

Each node of a network is individually connected to the bus. The data flow is bidirectional. When transmitting data, the sender device puts the data onto the bus with the receiver information. Every computer connected to the bus examines the data to determine who will receive the data. The receiver computer only receives the data and the others discard it.



### Advantages of bus Topology

1. Bus topology is cost effective and the installation is simple.
2. Using repeaters or connectors one can easily increase the length of the backbone thus expanding the network.
3. New devices can be added to the network at any time.
4. Even if any node is disconnected from the network or is disabled, the network keeps running.
5. No centralised server is required.

### Disadvantages of bus topology

1. Data transfer rate is slower.
2. If there is a problem with the bus the whole network suffers.
3. Adding computers to the network and expanding the network increases the network traffic and decreases network speed.
4. Chances of data collision.

### Ring Topology

In ring topology the computer devices are connected in a circular fashion with one another to form a ring. In this network the first device and the last device are connected to form a ring. No central server is needed in this topology.

Each computer in this network gets equal opportunity to send and receive data. When a node sends a signal, it is transmitted to the node next to it. If the next node is the receiver it receives the data, if it is not the receiver it passes the signal to the next node until the receiver is reached.

### Advantages of Ring Topology:

1. No centralised server is required.
2. Data flow is one directional so no chance of data collision.
3. Each computer gets equal priority in sending data.
4. Requires less cable so cost effective.



Figure 2.35: Ring topology

### Disadvantages of Ring Topology

1. Data transfer rate is slower.
2. As the data flow is unidirectional and each computer receives and passes on the data until the destination is reached, if one computer device in the network is disabled. The whole network becomes disabled.
3. Adding or removing a computer device into the network disrupts the whole network.
4. Increasing the number of computer devices in the network increases the data transmission time too.
5. Complex softwares is needed to manage this topology.

### Star Topology:

In star topology different computer devices and peripheral devices are connected to each other with a central hub or a switch. The devices in this topology use the hub or the switch to communicate and send/receive data between themselves. Data transmission requires less time and there is less chance of a data collision. The data flow is bidirectional. If there is a problem in any part of the network it is easily detectable through the hub or switch. Twisted pair cables are generally used to construct this topology.



Figure 2.36: Star topology

### Advantages of Star Topology

1. Data transfer rate is faster
2. Less chances of data collision
3. Adding or removing nodes from the network does not disrupt the network.
4. The network keeps running even if one or more nodes are disabled or disconnected.
5. Increasing the number of network devices does not affect the data transfer rate.

### Disadvantages of Star Topology

1. Problems with the hub or switch can disable the whole network
2. Each node requires cables of their own, so increases cost.
3. Two computers in a network can not directly communicate with each other.

### Tree Topology

In Tree topology the network nodes are interconnected like branches of a tree. In this topology different levels of computer devices are connected with a central host computer or a server. Different levels of hierarchy are maintained while connecting different computer devices via hubs or switches. This is why it is also known as a hierarchical topology. In this system each computer acts as host computers for the next level of hierarchy. The last level is called the peripheral terminal as it does not have another level after it. A tree topology can be expanded. The data flow in this topology is bidirectional.



Figure 2.37: Tree topology

### Advantages of Tree Topology

1. Can expand the network easily with expanding a branch or adding a new branch.
2. This provides a better system while constructing a large network.
3. The network does not face any disruption if one or more nodes are disconnected or disabled.
4. Data security is higher.
5. If a branch is disabled or disconnected the rest of the network can still be running.

### Disadvantages of Tree Topology

1. If the root host server is disabled or disconnected the whole network is disabled.
2. This is more complex than other topologies.
3. This is more costly than other topologies.
4. If a computer in the network is disabled the devices connected to it in lower levels are disconnected too.

### Mesh Topology

In mesh topology every device in the network is directly connected to every other device in the network. In this system every device can make faster and direct communication with other devices present in the network. This system does not need a centralised server computer. This connection between the computers is called peer to peer links. This topology is also known as a completely interconnected topology. This needs a lot of wiring and devices, so it is more costly.



Figure 2.38: Mesh topology

Due to its complex configuration it is not generally used in computer networking. If the network in mesh topology has number of nodes, in that case each node will need  $n-1$  connections. So the number of wires needed is  $n(n-1)/2$ . Mesh topology is only used where the priority is data security and the dependability and reliability of a network. Defence sector and banking sectors use this kind of topology.

#### Advantages of Mesh Topology

1. Data transfer rate is faster.
2. Increasing computer devices in the network does not affect the data transmission speed.
3. The network keeps running even if one or more devices inside the network are disconnected or disabled.
4. Data transmission can continue even if one or more cables are disconnected or disabled.
5. No centralised server is required.

#### Disadvantages of Mesh Topology

1. This is more costly than any other topology
2. Installation and configuration of the network is complex.
3. Cost increases if a new device is added to the network.

#### Hybrid Topology

Hybrid topology accompanies star, ring, mesh and bus topologies. This is used when for some particular needs, one type of topology does not meet all of the requirements. The internet is based on hybrid topology. The Internet has all types of network topologies connected to it.

#### Advantages of Hybrid Topology

1. Network can be easily expanded using hubs or switches.
2. Troubleshooting of the network is easier.
3. If a part of the topology is disabled or disconnected, it does not affect other parts of the network.
4. As this is a combination of all other topologies it has the advantages of the other topologies too.

#### Disadvantages of Hybrid Topology

1. The maintenance cost is higher and the maintenance of this system is complex.
2. Installation and configuration of this system is complicated.
3. As this is a combination of all other topologies, it has the disadvantages of the other topologies too.

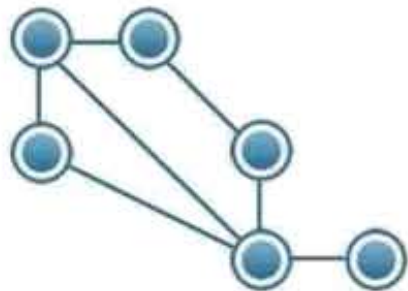

Figure 2.39: Hybrid topology

### 2.5.7 Cloud Computing

Simply put, cloud computing is the delivery of computing services—including servers, storage, databases, networking, software, analytics, and intelligence—over the Internet (“the cloud”) to offer faster innovation, flexible resources, and economies of scale. You typically pay only for cloud services you use. It helps you lower your operating costs, runs your infrastructure more efficiently, and scales as your business needs change.

In the modern era cloud computing plays a very important role as most of the services available online are run on cloud. We use the internet to go into our social media and email accounts. We use these services for free. We can use these services because these companies have countless servers in many different countries around the globe catering to our needs. There are companies who provide you services against a payment. Both the free and premium services fall under the cloud computing systems. Cloud computing is not a technology, it is a business model in which the customers use their own computers or devices to access services, softwares, storage spaces from the providers who have servers situated anywhere in the ‘cloud’.

**Cloud Computing can be categorized into three types:**

**Private Cloud:** A singular organization has the ownership and control of the management of a cloud computing system here. This type of cloud is generally used and maintained by large organizations as though it is very expensive, it is more cost effective than managing multiple data centers across all of the organization's premises.

**Public Cloud:** The cloud services that are open to the public on the internet is known as the public cloud. Public cloud offers different services to the public which includes softwares, processing power, database, storage space and many more with or without payments. Companies like Amazon, Google, Microsoft have their own infrastructure and data centers around the world to make these types of public cloud services available to people all over the world.

**Hybrid Cloud:** As the name suggests, hybrid cloud is the combination of private and public or community clouds. Cloud services are combined into hybrid clouds to increase their efficiency and expand their coverage.

### 2.5.8 Advantages of Cloud Computing

**The services provided by the cloud computing organizations can be divided into four types:**

**IaaS Infrastructure as a service:** In this model service infrastructures are rented out via the cloud. Amazon's elastic computing cloud or EC2 is a popular model of this kind. Each EC2 server machine runs 1 to 8 virtual machines. These machines are rented out to the customers. Customers can install any kind of operating systems and softwares in these virtual machines and run application softwares of their choosing.

**PaaS Platform as a Service:** In this model rather than renting out virtual machines, computing platforms are rented out as services. This can include operating systems, development environment, execution environment, database, web servers and such. Customers can use this type of cloud services for application development without having to buy expensive computing systems on their own. Microsoft's Azure and Google's App Engine are prime examples of PaaS.

**SaaS Software as a Service:** In this model customers get access to the service application and their databases. So the customers do not have to use their own storage, processing power for the softwares or maintain and update it in anyways. Google Drive is a very popular SaaS system. Example of this model are Google App, Dropbox, Hubspot etc.

**Network-Based Services (Naas: Network as a Service) :** This is a model where customers rent network services from a cloud vendor instead of setting up their own network infrastructure. For example, the organization of Arjaca and Partino provides services of WAN and SVPN (Secure Virtual Private Network).

**Cloud service users also get the following benefits:**

**Resource Flexibility and Scalability:** Cloud services can cater to customers of any kind. Customers can increase or decrease their demand at any time and cloud services can cater to that instantly and remotely.

**On Demand Services:** Cloud services work as on demand service models. Customers can start or end their services at any given moment.

**Pay as You Go:** Customers do not have to pay in advance for any services. The payment will be according to the amount of the service taken. If the customer did not use a portion of a service he needs not pay for it.

**Opportunity for Entrepreneurs:** Cloud computing and cloud services have opened a vast amount of doors for the budding entrepreneurs. Now to start up a business you do not need your own hardwares and most of the essential softwares and database systems are available for rent on the cloud. You do not need maintenance for cloud softwares, no need to manage or purchase license keys. Most of the cloud services and applications are easy to use and can be operated by people with moderate knowledge about the internet.

Cloud computing has really expanded the horizons for us in the field of information technology. But like all good things this system has some risks attached. Data ownership and privacy of information is a very sensitive issue in the cloud computing world. As the customers do not have a clue where his data is located or processed, it can create issues regarding data security and privacy.

## Exercise

### MCQ

1. What is the unit of data transfer?
  - a. Band Meter
  - b. Bandwidth
  - c. Data Transmission
  - d. Data Connection
2. A group SMS is -
  - a. Unicast
  - b. Multicast
  - c. Broadcast
  - d. Telecast
3. Which device can perform data filtering?
  - a. Hub
  - b. Switch
  - c. Repeater
  - d. Router
4. Bit synchronisation is -
  - i. A combined system to transmit bits
  - ii. The arrangement of bits of data and an extra bit.
  - iii. Extra bandwidth
 Which is true?
  - a) i and ii
  - b) i and iii
  - c) ii and iii
  - d) i, ii and iii
5. The purpose of a computer network is -
  - i. Sharing hardware resources
  - ii. Sharing software resources
  - iii. Connecting multiple computers
 Which one is true?
  - a) i and ii
  - b) i and iii
  - c) ii and iii
  - d) i, ii and iii

**Read the following passage and answer the questions no 6 & 7:**

One day Humaira went to his father's office and saw that his father gave a print command from his computer and another officer in that room gave a print command from his own computer. But the print out was made from the same printer. Humaira's father used his computer to talk with another officer out of the country.

6. The network described in the passage is -
  - i. LAN
  - ii. WAN
  - iii. MAN
 Which one is true?
  - a) i and ii
  - b) i and iii
  - c) ii and iii
  - d) i, ii and iii
7. In the described system one can have -
  - i. More services from a small device
  - ii. Easy communication with clients
  - iii. Limited work in a small area





2.

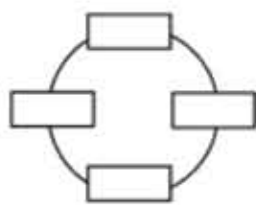

Figure 1

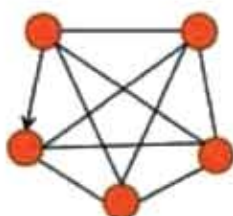

Figure 2

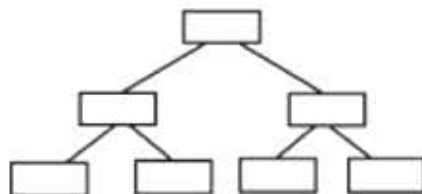

Figure 3

- a. What is Modulation?
  - b. Explain data transfer modes.
  - c. Explain the Network Topology In figure 1.
  - d. Between figure 2 and 3, what advantages and disadvantages will you get from applying each of these? Explain.
3. Shawpna was sharing data for free with his colleague Arif who sits on another floor. Meanwhile another colleague from the fifth floor asked for a file and Shawpna sent the file to his colleague without getting up from his seat. Shawpna also sent another file to one of his colleagues who is out of the country.
- a. What is full duplex?
  - b. Explain the transmission of data blocks as packets.
  - c. Explain the network Shawpna used to transfer files to Arif.
  - d. The second network is better than what was used with Arif, explain.
4. An educational institution brought computers from different floors under one network. But after a few days one computer machine was not running and that disrupted the whole network.
- a. What is a Bridge?
  - b. Explain the concepts of wireless communication.
  - c. What Network Topology did the educational Institution use?
  - d. To avoid disruption, what Network Topology should they use? Explain your answer.

## Chapter Three

### Number Systems and Digital Devices

---



Bangladeshi students participating in international robotics competitions

Science and technology always had the greatest impact in the history of human civilization. Modern science and the modern world owes most of their debt to computers and electronic gadgets we hold so dear nowadays. Not so long ago we needed a whole building complex to reside a computer. But now we carry a mobile phone in our pockets with vastly more computing power than all of those early computers combined. These computers and electronic gadgets are based upon a field of study we call Digital Electronics. This branch of study relies on a mesmerizingly simple mathematical structure called binary numbers and Boolean Algebra. In this chapter you will be introduced with the fundamentals of this system.

**At the end of this chapter students will:**

1. Learn the history of discovering the numbers
2. Be able to explain number systems
3. Know the classifications of number systems
4. Determine the interrelations between the number systems
5. Be able to add and subtract in binary
6. Determine 2's complement
7. Learn the concept of coding
8. Compare different codes
9. Know the concepts of Boolean Algebra
10. Prove Boolean Theorems
11. Use logic operators in practical scenarios for Boolean Algebra
12. Explain inner workings of digital devices tied with Boolean Algebra

### 3.1 History of Inventing Numbers

---

We use both languages and numbers in every sphere of our daily lives. Necessity drove us to discover numbers alongside languages. Even some animals and birds can count up to an extent. It is strange to us but in the far reaches of the world there are many aboriginal groups who do not know how to count because they do not need numbers in their day to day lives. There is an indigenous tribe called Piraha in Brazil who can count only upto 2. More than two of something and they describe it as 'many'.

In ancient times when the humans were hunter gatherers, they did not have much use of numbers and counting. But when human civilization learned agriculture, farmed animals, built cities and settled down - then the need for accounting crept up on them. That is why the history of human civilization and the history of numbers are interconnected in so many ways. Necessity made us learn how to count huge numbers, made us learn what to do with numbers and how to process them.

Prehistoric people used scratches on bones, tree branches and stones or seashells or small stones to keep track of numbers. But eventually the ancient human beings felt the need for much larger numbers that can not be kept track with just scratches or seashells. That's why they invented symbols to represent numbers. About five thousand years ago the Sumerian-Babylonian civilization and the Egyptian civilization were booming and in both cases we found that they had invented number systems using written symbols. The Sumerian-Babylonian number system was 60 base and the Egyptian number system was 10 based or decimal number system. We still use the Egyptian decimal system in current day and time and we have traces of the 60 based number system in our counting of time and angles. Seconds, minutes, hours are 60 based so are the angles we calculate in a plain. Both these ancient systems used different symbols to represent nothingness but they had not invented the number zero. Three more civilizations played important roles in developing the number system - the Mayan Civilization, Chinese civilization and the Indus river valley civilization. Mayan number system was 20 based and Chinese and Indian number systems were decimal. Traces of the 20 based number system can still be found in our villages while counting weights or lengths. Both the Mayan and Indian number systems used local values of the numbers. Indians were the first people to use zero as a number in their system, this was a revolutionary discovery in the history of mathematics. Mayans and Chinese number systems used two or three symbols to express all the numbers, whereas the Indian system used nine separate symbols to express numbers from 1 to 9 and one different symbol for 0 - a total of ten symbols. These symbols are known as digits.

The Greeks developed a decimal number system based on the Sumerian-Babylonian and the Egyptian number systems. The Greek revolution in the field of mathematics was cut short by the Roman conquest of the Greek empire. The Roman empire did not feel the need for much mathematics in their lives. They did not have separate symbols for all the digits. Numbers were expressed via Roman numerals.

Hindu-Arabic	Roman	Greek	Egyptian	Babylonian	Chinese	Mayan
0				𐎶	○	☉
1	I	Α	𐦏	𐎶	一	·
2	II	Β	𐦏𐦏	𐎶𐎶	二	··
3	III	Γ	𐦏𐦏𐦏	𐎶𐎶𐎶	三	···
4	IV	Δ	𐦏𐦏𐦏𐦏	𐎶𐎶𐎶𐎶	四	····
5	V	Ε	𐦏𐦏𐦏𐦏𐦏	𐎶𐎶𐎶𐎶𐎶	五	—
6	VI	Ϝ	𐦏𐦏𐦏𐦏𐦏𐦏	𐎶𐎶𐎶𐎶𐎶𐎶	六	— ·
7	VII	Ζ	𐦏𐦏𐦏𐦏𐦏𐦏𐦏	𐎶𐎶𐎶𐎶𐎶𐎶𐎶	七	— · ·
8	VIII	Η	𐦏𐦏𐦏𐦏𐦏𐦏𐦏𐦏	𐎶𐎶𐎶𐎶𐎶𐎶𐎶𐎶	八	— · · ·
9	IX	Θ	𐦏𐦏𐦏𐦏𐦏𐦏𐦏𐦏𐦏	𐎶𐎶𐎶𐎶𐎶𐎶𐎶𐎶𐎶	九	— · · · ·
10	X	Ι	𐦏𐦏𐦏𐦏𐦏𐦏𐦏𐦏𐦏𐦏	𐎶𐎶𐎶𐎶𐎶𐎶𐎶𐎶𐎶𐎶	十	==
50	L	Ν	𐦏𐦏𐦏𐦏𐦏𐦏𐦏𐦏𐦏𐦏𐦏	𐎶𐎶𐎶𐎶𐎶𐎶𐎶𐎶𐎶𐎶𐎶	五十	== ·
100	C	Ξ	𐦏𐦏𐦏𐦏𐦏𐦏𐦏𐦏𐦏𐦏𐦏𐦏	𐎶𐎶𐎶𐎶𐎶𐎶𐎶𐎶𐎶𐎶𐎶𐎶	一百	== · ·

Figure 3.1: Ancient numerals

That unscientific and unnecessarily complex system is still alive as we use them in clock faces and sometimes marking literary topics.

With the expansion of Islamic civilization, the Indian decimal number system found their way into Europe. The symbols we use now 1,2,3 ... are all Arabic numerals. Funny part here is, the christian rulers resisted the concept of adopting the number zero by spreading propaganda that it is the devil's number.

Decimal number system was made popular due to the fact that we have ten digits on our hand. But later the 2, 8 and 16 based number system gained popularity in the modern age.

### 3.2 Number System

A number system is defined as a system of writing to express numbers. We use many different notations and symbols to denote numbers. These symbols are used in two different ways.

#### 3.2.1 Classification of Number System

Number systems can be classified into two types: non positional and positional system.

##### Non Positional Number System:

In a non positional system, the symbol will maintain its value no matter where it is placed or positioned. Roman numbers are examples of non positional number systems. For example - In Roman numerals the symbol V is used to express the

number 5. But in VI, VIII, XV although the symbol V is in three different positions but all of them express the value 5. Non positional numbers were popular in ancient times.

### **Positional Number System**

In this system the value of the number is dependent upon the position of the symbols. With the invention of the modern number theory positional number system was made popular. The decimal number system we use in our daily lives are an example of the positional number system. For example, the number 555 has three 5 symbols but each has different values. The leftmost 5 means 500 while the middle 5 means 50. Each position has a local value in this number system. The rightmost digit has the local value of 1, the next digit has the value 10 and so on. Each position from left to right increases the local value with the multiples of 10 as it is a decimal or 10 based number system. If it was a 4 based number system, each position's local value would increase by the multiples of 4. If it was a 16 based system, each position from left to right would increase the local value with the multiples of 16.

Let us see some examples of different positional number systems.

### **Binary Numbers**

We are very familiar with the 10 based decimal number system as we use it in our daily lives. But for digital devices 10 based numbers are not very realistic as you would have to use 10 different values of voltage to represent 10 numbers. While using two different voltages for two numbers seems quite easy and cost effective. This is why digital electronics rely on the binary number system.

As we know, in the decimal number system we have ten different symbols or digits - 0,1,2,3,4,5,6,7,8,9. Similarly the binary number system has only two symbols or digits, 0 and 1. To express larger numbers in the binary number system we have to use comparatively more digits than the decimal system, this is the only limitation of the binary number system. Any number can be expressed using the binary number system. Any type of mathematical operations can be performed using the binary number system too.

As it is a positional number system, each position has a local value. In the decimal number system the local value increases in multiples of 10s like 100, 101, 102, 103 and such. Similarly in the binary number system the local values increase with the multiples of 2, like 20, 21, 22, 23 and such. To express fractions, decimal numbers decrease in 10s multiples like 10<sup>-1</sup>, 10<sup>-2</sup>, 10<sup>-3</sup> and such. Similarly binary numbers decrease after the radix point like 2<sup>-1</sup>, 2<sup>-2</sup>, 2<sup>-3</sup> .... As such to compare let us observe the following table of decimal and binary numbers—

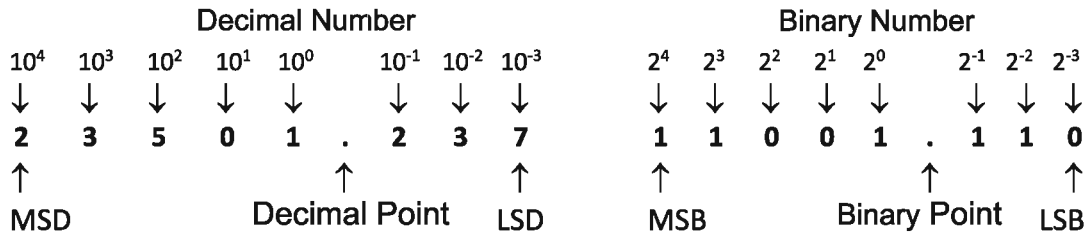

Here MSD and LSD means Most Significant Digit and Least Significant Digit. Similarly MSB and LSB means Most and Least Significant bits. Like in decimal numbers, to determine a binary numbers value we have to multiply each bit with their local value and add them up.

$$\begin{aligned}
 11001.110_2 &= 1 \times 2^4 + 1 \times 2^3 + 0 \times 2^2 + 0 \times 2^1 + 1 \times 2^0 + 1 \times 2^{-1} + 1 \times 2^{-2} + 0 \times 2^{-3} \\
 &= 16 + 8 + 4 + 0 + 0 + 1 + 0.5 + 0.25 + 0 \\
 &= 25.75_{10}
 \end{aligned}$$

Here the subscript with 2 and 10 are there to represent the base of the numbers so we can know which is a binary number and which is a decimal number. The number of digits needed in a number system is referred to the base. That is why the decimal system has a base of 10 and the binary system has a base of 2. Similarly the octal system has a base of 8 and the hexadecimal system has a base of 16. Generally we do not write the base of the system alongside the numbers unless we are using more than one number system in conjunction. This is done to avoid confusion.

In this chapter we are aiming to learn the number systems needed for operating digital devices where fractions are not required. This is why further discussions about number systems will revolve around whole numbers only.

**Table: 3.1**

Local Value				Decimal Number
$2^3= 8$	$2^2= 4$	$2^1= 2$	$2^0=1$	
0	0	0	0	0
0	0	0	1	1
0	0	1	0	2
0	0	1	1	3
0	1	0	0	4
0	1	0	1	5
0	1	1	0	6
0	1	1	1	7
1	0	0	0	8
1	0	0	1	9
1	0	1	0	10
1	0	1	1	11
1	1	0	0	12
1	1	0	1	13
1	1	1	0	14
1	1	1	1	15

3.1 table displays the some serially arranged values of decimal and binary numbers to compare.

### Octal Numbers

Octal number system has a base of 8. The eight digits used to define octal numbers are 0,1,2,3,4,5,6 and 7. 3.2 table denotes the decimal numbers from 0 to 16 and their octal counterparts.

**Table: 3.2**

Decimal Number	Octal Number	Decimal Number	Octal Number
0	0	8	10
1	1	9	11
2	2	10	12
3	3	11	13
4	4	12	14
5	5	13	15
6	6	14	16
7	7	15	17

### Hexadecimal Numbers

Hexadecimal system has a base of 16 so 16 different digits are needed to express hexadecimal numbers. These sixteen digits consist of the numbers 0 to 9 and letters A,B,C,D,E and F. 3.3. Table shows the hexadecimal and the binary counterparts of the decimal numbers 0 to 16. 4 binary bits are needed to express one hexadecimal digit. That is why the hexadecimal 10 is written as 00010000 instead of

**Table: 3.3**

Decimal Number	Hexadecimal Number	Binary Number	Octal Number
0	0	0000	0
1	1	0001	1
2	2	0010	2
3	3	0011	3
4	4	0100	4
5	5	0101	5
6	6	0110	6
7	7	0111	7
8	8	1000	10
9	9	1001	11
10	A	1010	12
11	B	1011	13
12	C	1100	14
13	D	1101	15
14	E	1110	16
15	F	1111	17
16	10	00010000	20

### 3.2.2 Conversion of Numbers

#### Binary to Decimal

To convert a binary number to a decimal number we need to multiply the values with their local 2 based multiplier. An example should clear that up:

$$\begin{aligned}
 101101_2 &= 1 \times 2^5 + 0 \times 2^4 + 1 \times 2^3 + 1 \times 2^2 + 0 \times 2^1 \\
 &\quad + 1 \times 2^0 \\
 &= 32 + 0 + 8 + 4 + 0 + 1 \\
 &= 45_{10}
 \end{aligned}$$

#### Decimal to Binary

Similarly to convert a decimal number to a binary number, we need to express the decimal number as summation of 2's multipliers.

$$\begin{aligned}
 25_{10} &= 16 + 8 + 4 + 0 + 0 + 1 \\
 &= 1 \times 2^4 + 1 \times 2^3 + 0 \times 2^2 + 0 \times 2^1 + 1 \times 2^0 \\
 &= 11001_2
 \end{aligned}$$

An easy way to get the summation of 2's multipliers is to divide the decimal numbers by 2 until the quotient is 0. The remainders will be the bits from LSB to MSB. For example, for the number 25.

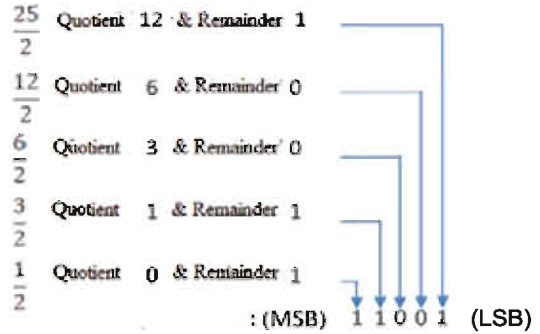

If we have grasped the basic idea of the conversion we can do a shortcut to it. Lets convert 37 to a binary number.

We can use the same technique to convert a decimal number to any base number. We just have to divide by the base instead of 2.

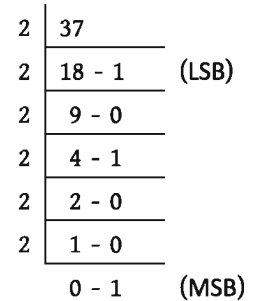

**Conversion of decimal number to binary number in case of fraction :** Let us begin with the all fraction and multiply by 2. The whole number part of the result is the first binary digit to right of the point. Next we disregard the whole number part of the previous result and multiply 2 once again. The whole number part of this new result is the second binary digit to the right of the point.

**Example: Convert (.46)<sub>10</sub> to Binary**

**1<sup>st</sup> Method**

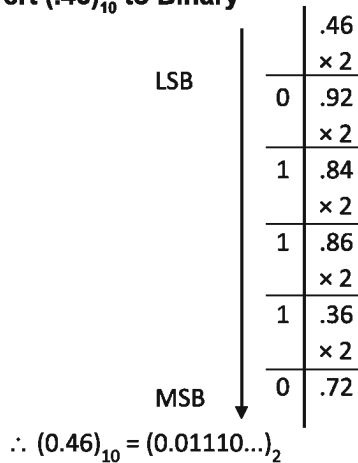

**Alternative Method**

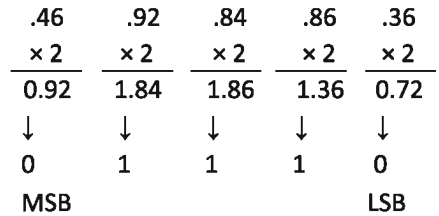

(.46)<sub>10</sub> = (0.01110...)<sub>2</sub>

LSB = Least Significant Bit

MSB = Most Significant Bit

**Decimal to Octal**

Let us use the previously demonstrated technique to convert the decimal number 710 to an octal number. We will divide by 8 instead of 2 as the base of the octal number system is 8.

Binary Number: 100101

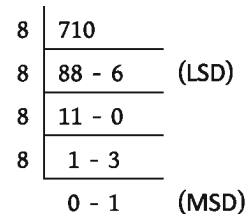

Octal Number: 1306



**Conversion of decimal number to octal number in case of fraction :** Let us begin with the decimal fraction and multiply by 8. The whole number part of the result is the first octal digit to the right of the point. Next we disregard the whole number part of the previous result and multiply by 8 once again.

**Example:** Convert  $(123.45)_{10}$  to octal number

**Integer Part**

8	123	
8	15	3
8	1	7
	0	1

$\uparrow$   
 LSB

$\uparrow$   
 MSB

$\therefore (123.45)_{10} = (173.34631.....)_8$

<b>Fraction Part</b>	.45
	× 8
3	.60
	× 8
4	.80
	× 8
6	.40
	× 8
3	.20
	× 8
1	.60

$\downarrow$   
 MSB

$\downarrow$   
 LSB

**Conversion of octal to decimal By:** Multiplying each digit of the octal number we're trying to convert by  $8^n$ , where  $n$  is the "weight" of the digit. The "weight" is the position of the digit, starting from 0 on the right. Now add the results.

**Example:** Convert  $(123.45)_8$  to decimal.

2	1	0	-1	-2
$\uparrow$	$\uparrow$	$\uparrow$	$\uparrow$	$\uparrow$
1	2	3	.4	5

$$\begin{aligned}
 & 1 \times 8^2 + 2 \times 8^1 + 3 \times 8^0 + 4 \times 8^{-1} + 5 \times 8^{-2} \\
 & = 64 + 16 + 3 + 4/8 + 5/8^2 \\
 & = 83 + 4/8 + 5/64 \\
 & = 83 + 0.5 + 0.078125 \\
 & = 83.578125 \\
 & \therefore (123.45)_8 = (83.578125)_{10}
 \end{aligned}$$

Do it yourself: Fill the blank spaces of the following table

Decimal	Octal
71	107
72	110
73	
74	
75	

Decimal	Octal
76	
77	
78	
79	
80	

Octal	Decimal
41	
42	
43	
44	36
45	37

Octal	Decimal
46	
47	
50	
51	
52	

**Octal to Binary**

Octal numbers can be very easily converted to binary numbers. The digits in octal numbers are 0,1,2,3,4,5,6,7 and each of these digits can be expressed with 3 bit binary numbers as such:

<b>Octal :</b>	0	1	2	3	4	5	6	7
<b>Binary :</b>	000	001	010	011	100	101	110	111

Using this we can express each digit of an octal number with their 3 bit binary counterpart thus converting the number. An example will be helpful:

$$412_8 = \begin{matrix} & 4 & 1 & 2 \\ & 100 & 001 & 010 \end{matrix} = 100001010_2$$

$$1453_8 = \begin{matrix} & 1 & 4 & 5 & 3 \\ & 001 & 100 & 101 & 011 \end{matrix} = 001100101011_2$$

**Binary to Octal:**

The same method mentioned above can be used to easily convert octal numbers to binary numbers. Starting from LSB we will divide the binary numbers into groups of 3 bits. If the leftmost group does not have 3 bits we will add zeros to make a 3 bit number. Then each group of 3 bits will be converted to corresponding octal numbers. Let us see an example -

$$10100101011_2 = \begin{matrix} & 010 & 100 & 101 & 011 \\ & 2 & 4 & 5 & 3 \end{matrix} = 2453_8$$

**Hexadecimal to Decimal**

To convert a hexadecimal number to a decimal number we will multiply the local values with multiples of 16 and add them up just like we did when converting from binary to decimal. The multipliers would be 16<sup>0</sup>, 16<sup>1</sup>, 16<sup>2</sup> and so on.

$$356_{16} = 3 \times 16^2 + 5 \times 16^1 + 6 \times 16^0 = 768 + 80 + 6 = 854_{10}$$

$$2AF_{16} = 2 \times 16^2 + 10 \times 16^1 + 15 \times 16^0 = 512 + 160 + 15 = 687_{10}$$

Note that in the second example A was replaced with 10 and F was replaced with 15.

**Conversion of hexadecimal to decimal in case of fraction:** The place values to the right of the radix point (what we call the equivalent of the "decimal point" when working in other bases) are simply negative powers of sixteen:

**Example:** Convert (AB.CD)<sub>16</sub> to decimal

$$A(10) \times 16^1 + B(11) \times 16^0 + C(12) \times 16^{-1} + D(13) \times 16^{-2}$$

$$= 160 + 11 + \frac{12}{16^1} + \frac{13}{16^2}$$

$$= 171 + \frac{3}{4} + \frac{13}{256}$$

$$= 171 + 0.75 + 0.0507$$

$$= 171.8007$$

$$\therefore (AB.CD)_{16} = (171.8007)_{10}$$

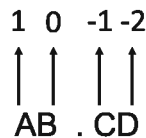

**Decimal to Hexadecimal**

We will use the same method as shown while converting to octal or binary numbers. As the base is 16 we have to divide by 16 in each step. If the remainder is between 10 and 15 it should be replaced with the letters A to F accordingly.

16	7106	
16	444 - 2	(LSD)
16	27 - 12	(C)
16	1 - 11	(B)
	0 - 1	(MSD)
<b>Hexadecimal</b>		<b>1BC2<sub>16</sub></b>

**Conversion of decimal to hexadecimal number in case of fraction :** Let us begin with the decimal fraction and multiply by 16. The whole number part of the result is the first hexadecimal digit to the right of the point. Next we disregard the whole number part of the previous result and multiply by 16 once again. The whole number part of this new result is the second hexadecimal digit to the right of the point.

**Example:** Convert  $(.71)_{10}$  to hexadecimal number.

<b>1<sup>st</sup> Method:</b>	.71	×16	<b>Alternative Method:</b>	.71	.36	.76
	B (11)	.36		× 16	× 16	× 16
	5	.76		11.36	5.76	12.16
	C (12)	.16		↓	↓	↓
				B	5	C

$\therefore (0.71)_{10} = (0.B5C\dots)_{16}$ 
 $\therefore (0.71)_{10} = (0.B5C\dots)_{16}$

### Hexadecimal to Binary

We used three bit binary numbers in the case of octal. Now we will use the same method but use 4 bit binary numbers instead of 3 bits.

$$9F23_{16} = \begin{array}{cccc} 9 & F & 2 & 3 \\ 1001 & 1111 & 0010 & 0011 \end{array} = 1001111100100011_2$$

### Binary to Hexadecimal

To convert binary to hexadecimal number, we will divide the binary numbers into groups of 4 bits from MSB to LSB. If the leftmost group does not have 4 bits then pad it with zeros. Then replace each 4 bit number with corresponding hexadecimal digits.

Example:  $10110111000011_2 = \begin{array}{cccc} 0010 & 1101 & 1100 & 0011 \\ 2 & D & C & 3 \end{array} = 2DC3_{16}$

Hexadecimal system replaces 4 binary bits into a digit so this system or the octal system is used when expressing very large binary numbers.

**Problem:** Write down 25 consecutive hexadecimal numbers starting from 38. What is the decimal value of 38

The easiest way to convert from octal to hexadecimal or vice versa is to convert the numbers first into binary numbers. Then used the above mentioned methods to convert to octal or hexadecimal as necessary.

$$B2F_{16} = \begin{array}{ccc} 1011 & 0010 & 1111_2 \\ B & 2 & F \end{array} = \begin{array}{cccc} 101 & 100 & 101 & 111_2 \\ 5 & 4 & 5 & 7 \end{array} = 5457_8$$

In the above example to convert the hexadecimal number B2F16 to octal number first the three digits were transformed into 12 binary digits. Then the 12 digits were rearranged to be in 4 groups of 3bits. Then we use the previously mentioned method to convert the group of 3 bits to octal number 54578.

### 3.3 Addition and Subtraction in Binary Systems

The binary number system is a similar number system to the decimal system we regularly use. So we can add and subtract binary numbers following the same rules that we use while adding and subtracting decimal numbers.

Binary addition	Binary subtraction
$\begin{array}{r} 101\ 100\ 101 \\ 11\ 001\ 001 \\ \hline 1\ 000\ 101\ 110 \end{array}$	$\begin{array}{r} 101\ 100\ 101 \\ 11\ 001\ 001 \\ \hline 10\ 011\ 100 \end{array}$

But as the use of the binary numbers are mainly for digital devices so some alternative methods are used to perform binary additions and subtractions. When we manually add or subtract, we do not need to know how many bits or digits the numbers have. But when an electronic circuit is performing binary addition or subtraction operations, it needs to know the number of bits the numbers have. That is because a circuit has a certain bit capacity and if the numbers or the result has more bits than its capacity we can not expect correct results from the operation. As digital devices use two different voltages to express the two binary bits 0 and 1, so any mathematical notations must be expressed using these bits too.

Some might think that digital devices have different circuits to perform additions, subtractions, multiplications or division operations. In reality we only need two circuits - to express a number in negative form and to add two numbers. For instance, to subtract two numbers a circuit just has to convert a number to negative then add the two numbers. For multiplication, a number has to be added with itself a certain number of times. To divide, one can use subtractions operations. We will gradually learn that if we can find a way to express negative numbers in binary we can perform any mathematical operations.

### 3.4 Signed Numbers

A very straightforward way to represent positive and negative binary numbers is to reserve the most significant bit for the sign. If the sign bit is 0 we can assume the number is positive, if it is 1 then we take it as a negative number. So, in the case of an 8-bit number, the first 7 bits will be used to represent the value of the number and the 8th bit will be reserved for the sign. While using signed numbers you have to keep in mind that you can not leave empty spaces. If you want to write +1 in 8bits it should be 00000001. The first 0 expresses that the number is positive and the last 7 bits express the value, which is 1. Similarly if you want to write -1 it cannot be 11. It should be expressed as 10000001. The first 1 represents the negative sign and the last 7 bits represents the value, which is 1. Following this rule here are some signed numbers as an example:

Number of 4 bits :

Decimal +2 =      0 010  
                           ↑ Value of number  
                           Signed number

Decimal -2 =      1 010  
                           ↑ Value of number  
                           Signed number

Number of 8 bits :	0 0110101	Decimal -77 =	1 1001101
Decimal +53 =	↑ Value of number		↑ Value of number
	Signed number		Signed number

But this way of representing signed numbers poses a serious problem. To explain the problem, let us write two 4 bits signed numbers, as always 1 bit is for sign and 3 bits are for the value.

0000 and 1000

Following our previous logic we know that the first number represents +0 and the later represents -0. But it is common knowledge that 0 is neither positive or a negative number. But with this system we have no way other than to accept both +0 and -0 numbers. The existence of +0 and -0 numbers can cause much complex problems in computing systems.

### 3.5 2's Complement

There is an elegant solution to escape the complexities of signed numbers. This is called 2's complement. But before delving into that we must first understand what a negative number is. A negative number is a number which produces a zero result while adding it with the same number. So if we have a binary number, to make it a negative number we have to find another binary number that will result in zero when we add it to our first number.

Let us start with an 8-bit binary number. Let's say the number is 10110011. Now let's make a 1's complement of the number, meaning that lets replace each 1 with a 0 and each 0 with a 1

The number:            10110011  
 1's complement        01001100  
 Adding the numbers:  11111111:

This is the highest number in 8-bit. If we add 1 to this number this will no longer be an 8-bit number.

$$\begin{array}{r} 11111111 \\ +1 \\ \hline 100000000 \end{array}$$

As we want to be limited by 8bits, we can ignore the 9th bit and denote the number as 00000000 or zero. As we said previously that when we add a negative number to the base number we get zero as a result. So we can say that, if we get 1's complement of a binary number and add 1 to it, that will act as a negative of the first number. This number is called the 2's complement of a number.

So now, we can get the negative of 10110011 by 2's complement

Initial number:        10110011  
 1's complement        01001100  
 Add 1                            1  
 2's complement        01001101

Now we can say that 01001101 is the negative of the 8-bit number 10110011. We know that double negative makes a number positive. So let us see that this works with the 2's complement system too.

Initial number:	01001101
1's complement	10110010
Add 1	1
2's complement	10110011

So we got back our first number. This proves that 01001101 and 10110011 are the negatives of each other.

We now know how to express a binary number in its negative form using the 2's complement. Now the question is, given a binary number, do we have a way to tell if it's an initial number or a 2's complement negative number? For example 1001 is a 4-bit binary number whose decimal value is 9. The 2's complement of 1001 is 0111 whose decimal value is 7.

Initial number:	1001
1's complement	0110
Add 1	1
2's complement	0111
Initial number:	0111
1's complement	1000
Add 1	1
2's complement	1001

So the question here is, do we consider 1001 as +9 and 0111 as -9? Or do we get 0111 as +7 and its 2's complement negative number 1001 as -7? To get rid of this confusion a simple rule is followed. If the MSB is 0, the number is positive and it corresponds to its decimal value. If the MSB is 1 then we consider the number as negative and to get the initial value we have to take the 2's complement of it.

4-bit example

+610 =	0110
1's complement	1001
Add 1	1
2's complement -610 =	10102

8-bit example

+8310 =	01010011
1's complement	10101100
Add 1	1
2's complement -8310 =	101011012

**Example:** Subtract 2510 from 5010 using the 2's complement method

$$\begin{array}{r}
 +2510 = \quad\quad\quad 00011001 \\
 1\text{'s complement} \quad 11100110 \\
 \text{Add 1} \quad\quad\quad\quad\quad 1 \\
 \hline
 2\text{'s complement } -2510 = 111001112 \\
 \\
 +5010 = \quad 001100102 \\
 -2510 = \quad 111001112 \\
 \hline
 1000110012
 \end{array}$$

The 8th bit in the result is an overflow bit and should be ignored. If we consider the result as an 8-bit number, we can see that the MSB is 0 or the result is positive. The result 000110012 = +2510

**Example:** Subtract 5010 from 2510 using the 2's complement method

$$\begin{array}{r}
 +5010 = \quad\quad\quad 00110010 \\
 1\text{'s complement} \quad 11001101 \\
 \text{Add 1} \quad\quad\quad\quad\quad 1 \\
 \hline
 2\text{'s complement } -5010 = 111001102 \\
 \\
 +2510 = \quad 000110012 \\
 -5010 = \quad 111001102 \\
 \hline
 111001112
 \end{array}$$

Here we can see from the MSB that the result is negative. So we have to use 2's complement method to get the actual value.

$$\begin{array}{r}
 \text{Result} = \quad\quad\quad 11100111 \\
 1\text{'s complement} \quad 00011000 \\
 \text{Add 1} \quad\quad\quad\quad\quad 1 \\
 \hline
 2\text{'s complement} = 000110012 \\
 \text{So the value of the result is } 000110012 = 2510 \\
 \text{And the actual result is } -2510
 \end{array}$$

## 3.6 Code

### 3.6.1 Concept of Code

As we have mentioned earlier, digital devices use two different voltages to conduct every digital operation. These voltages are used to define 0 and 1 and digital devices, and using the binary number system can be used to express any number and mathematical operations. But we all know that processing numbers and mathematical operations is not enough, a computer has to process characters, letters, symbols and all sorts of media files. As the electronic circuits can only recognize 0 and 1 so any character, letter, word and symbol need to be converted to 0s and 1s. This conversion of characters, letters, words and symbols to a binary system is known as coding. Let us discuss some different forms of codings.

### 3.6.2 Examples of Code

#### BCD

We use the decimal number system in every turn of our daily lives. To process these decimal numbers into computer circuits, we need to convert them to binary numbers. The Binary Coded Decimal or BCD method was invented to keep this conversion to binary numbers as close to our regular decimal system as possible.

Decimal	0	1	2	3	4	5	6	7	8	9
BCD	0000	0001	0010	0011	0100	0101	0110	0111	1000	1001

In this method, each of the 10 digits of the decimal number system are expressed as 4 bit binary numbers. Although we know that using 4 binary bits, we can express from 0 to 15. But in BCD 10 to 15 these six numbers are never used. We can express the decimal 10 to binary 1010 using only 4 bits but with BCD we need 8-bits to express the number 10 = 0001 0000. Let us see an example of BCD.

$4578_{10}$	4	5	7	8
BCD	0100	0101	0111	1000

**Example:** 100100100110 is a decimal number coded in BCD. What is the actual decimal number?

To get the original decimal number first we have to arrange the BCD code into groups of 4 bits. Then replace them with their corresponding decimal digits.

BCD	1001	0010	0110
Decimal	9	2	6

#### Alphanumeric Code

Computers use different symbols, characters, punctuations and signs alongside letters and numbers. In Alphanumeric codes one can use these symbols and signs alongside numbers. Some popular alphanumeric codes are explained below.

#### EBCDIC

Extended Binary Coded Decimal Interchange Code or EBCDIC is an 8bit code. As it is an 8bit code, it can be used to express 28 or 256 different symbols and digits. IBM first used this coding mechanism to express letters, symbols and numbers. During the 1960s the input system of computers used perforated cards. The EBCDIC coding took this into account as well while developing the scheme. This coding method is obsolete as we do not use that type of input anymore.



## ASCII

American Standard Code for Information Interchange or ASCII is a 7bit alphanumeric code. This scheme was first invented to be used in teleprinter, later it was adopted for use in computer devices. As this is a 7bit code it can be used to express 27 or 128 different symbols. The first 32 codes are used as control signals. Rest 96 codes are used to express small letters, capital letters of the English alphabet, mathematical symbols and signs, punctuations etc. As now we have 16, 32 and even 64 bit computers, we do not need to be restricted to 7 bits anymore. Now an 8bit Extended ASCII is used with another 128 symbols and signs. But the first 128 signs and symbols are still known as ASCII. The following table shows the ASCII code for the last 96.

**Table 3.4: Ascii Table**

Number	Symbol	Number	Symbol	Number	Symbol	Number	Symbol	Number	Symbol	Number	Symbol
32	Sp	48	0	64	@	80	P	96	`	112	p
33	!	49	1	65	A	81	Q	97	a	113	q
34	"	50	2	66	B	82	R	98	b	114	r
35	#	51	3	67	C	83	S	99	c	115	s
36	\$	52	4	68	D	84	T	100	d	116	t
37	%	53	5	69	E	85	U	101	e	117	u
38	&	54	6	70	F	86	V	102	f	118	v
39	'	55	7	71	G	87	W	103	g	119	w
40	(	56	8	72	H	88	X	104	h	120	x
41	)	57	9	73	I	89	Y	105	i	121	y
42	*	58	:	74	J	90	Z	106	j	122	z
43	+	59	;	75	K	91	[	107	k	123	{
44	,	60	<	76	L	92	\	108	l	124	
45	-	61	=	77	M	93	]	109	m	125	}
46	.	62	>	78	N	94	^	110	n	126	~
47	/	63	?	79	O	95	_	111	o	127	Del

**Unicode**

Unicode is an encoding system that acts on characters, letters, symbols, emojis, etc. from the ancient Egyptian hieroglyphic system to at present. Previous encoding methods such as ASCII and EBCDIC have also been brought under Unicode. That is, the writing medium of almost all the languages of the world has been integrated in Unicode system. An organization called Unicode Consortium launched the first version 1.0.0 in 1991 in 24 languages. The 13th edition has been launched in 2020 with 154 languages. Unicode has 3 most common formats/ standards. E.g.

1. UTF-8: This is a 8 bit (byte) unit. Here a character is represented between 1 and 4 bytes. That is, according to this format, a number between  $0000_{16}$  to  $10FFFF_{16}$  has been specified for each letter. For example,  $0041_{16}$  is the English letter 'A' and  $0995_{16}$  is the Bengali letter 'Ka' which is located in the range of UTF-8. It is the most widely used encoding method in email and the Internet.
2. UTF-16: This is a 16 bit (short) unit. Here a character is represented between 1 and 2 bytes. It is mainly used for data storage and text processing.
3. UTF-32: This is a 32 bit (long) unit. Here a character is represented within the prescribed 4 bytes. Characters are used skillfully here.

It is mentioned that UTF-8 and UTF-16 are the most common methods. Meanwhile, UTF-8 has become an unwritten standard for use on the website. This is because in this case 4 bytes of space is reserved for each letter, but in case of use, UTF-8 uses only as many bits as required.

**Table 3.5: Bangla Unicode**

	0	1	2	3	4	5	6	7	8	9	A	B	C	D	E	F
U+096x	।	ঁ	ং	ঃ		অ	আ	ই	ঈ	উ	ঊ	ঋ	ৠ			এ
U+099x	ঐ			ও	ঔ	ক	খ	গ	ঘ	ঙ	চ	ছ	জ	ঝ	ঞ	ট
U+09Ax	ঠ	ড	ঢ	ণ	ত	থ	দ	ধ	ন		প	ফ	ব	ভ	ম	য
U+09Bx	র		ল				শ	ষ	স	হ			়	ূ	া	ি
U+09Cx	ী	ু	ূ	্	্			ে	ৈ			ো	ৌ	্	ৎ	
U+09Dx								ী					ড়	ঢ়		য়
U+09Ex	ঋ	ৠ	ঌ	ৡ			০	১	২	৩	৪	৫	৬	৭	৮	৯
U+09Fx	ব	ব	।	।	।	।	।	।	।	।	।	।	।	।	।	।

## 3.7 Boolean Algebra and Digital Devices

---

### 3.7.1 Boolean Algebra

Everyone of us is more or less familiar with algebra. Boolean Algebra is a different kind of algebra where we work with only 0 and 1. The entirety of the digital electronics is built upon the concepts and workings of Boolean Algebra.

Boolean Algebra has only three mathematical operations: Complement, Multiply and Addition. These operations are very simple as we work with 0 and 1 only.

Boolean Complement: 0 is 1's complement and 1 is 0's complement. Which is written as  $0 = 1$  and  $1 = 0$ .

Boolean Multiplication:  $0.0 = 0$ ,  $1.0 = 0$ ,  $0.1 = 0$ ,  $1.1 = 1$

Boolean Addition:  $0 + 0 = 0$ ,  $0 + 1 = 1$ ,  $1 + 0 = 1$ ,  $1 + 1 = 1$

As we can see that most of the above mentioned concepts are familiar to us except the  $1 + 1 = 1$  rule. As we are only working with only 0 and 1, there is no alternate option too. Although in written form we are writing 0 and 1, we have to keep in mind that these are not actually numbers in a digital device but two different states like in electronic circuits they can be two different voltages like 0v and 5v, they can be light and dark states in optical fiber or true and false states of a logic gate.

In Boolean Algebra the order of the operations are, complement first, then multiplication and in the end addition. To keep the confusion to a minimum we can use brackets if there are multiple operations.

**Example:**  $1.0 + ((0 + 1)) = ?$

Solution:  $1.0 + ((0 + 1)) = 0 + 1 = 0 + 0 = 0$  .

### 3.7.2 Boolean Theorem

The Boolean Algebra has some theorems like we see in our regular algebra. Some important ones are shown below. As Boolean Algebra is made up with  $\{0,1\}$  set so we can put 0 and 1 in place of the variables and easily prove the theorems.

**Table 3.6: Boolean Theorem**

(Double Complement)	$\bar{\bar{x}} = x$
(Idempotent)	$x + x = x \quad x \cdot x = x$
(Identity)	$x + 0 = x \quad x \cdot 1 = x$
(Domination)	$x + 1 = 1 \quad x \cdot 0 = 0$
(Commutative)	$x + y = y + x \quad xy = yx$
(Associative)	$x + (y + z) = (x + y) + z$ $x(yz) = (xy)z$
(Distributive)	$x + yz = (x + y)(x + z)$ $x(y + z) = xy + xz$
(De Morgan)	$\overline{x \cdot y} = \bar{x} + \bar{y}$ $\overline{x + y} = \bar{x} \cdot \bar{y}$
(Absorption)	$x + xy = x$ $x(x + y) = x$

Most of these theorems will seem familiar to us, some of them will not.

**Example:** Prove the Distributive theorem  $x + yz = (x + y)(x + z)$

**Solution:**

**Example:** Prove the theorem,  $x + yz = (x + y) \cdot (x + z)$

**Answer:** Right side,  $(x + y) \cdot (x + z)$

$$= xx + xz + yx + yz$$

$$= x + xz + yx + yz \quad \text{Idempotent } x \cdot x = x$$

$$= x(1 + z) + yx + yz$$

$$= x + yx + yz \quad \text{Domination } 1 + z = 1$$

$$= x(1 + y) + yz$$

$$= x + yz \quad \text{Domination } 1 + y = 1$$

$$= \text{Left side (Proved)}$$

**Example:** Prove the De Morgan's Theorem with every possible values for both variables

**Solution:** As there are two variables,  $x$  and  $y$  in the theorem. There can be 4 different values for them as the values will be either 0 or 1.

$x$	$y$	$x \cdot y$	$\overline{x \cdot y}$	$\bar{x}$	$\bar{y}$	$\bar{x} + \bar{y}$
0	0	0	1	1	1	1
0	1	0	1	1	0	1
1	0	0	1	0	1	1
1	1	1	0	0	0	0

$$\overline{x \cdot y} = \bar{x} + \bar{y} \text{ (Proved)}$$

$x$	$y$	$x + y$	$\overline{x + y}$	$\bar{x}$	$\bar{y}$	$\bar{x} \cdot \bar{y}$
0	0	0	1	1	1	1
0	1	1	0	1	0	0
1	0	1	0	0	1	0
1	1	1	0	0	0	0

$$\overline{x + y} = \bar{x} \cdot \bar{y} \text{ (Proved)}$$

**Do It yourself:** Which boolean theorems are different from our regular algebra theorems? Hint: find the theorems that do not work with values other than 0 and 1.

In regular algebra we can use many different variables to build a large expression. Which is also true for Boolean Algebra? We can make larger statements and expressions using the Boolean Theorems. For example, the following expressions are made using three different variables:  $x, y$  and  $z$ .

$$xyz + xy + x$$

We can simplify it as such:

$$xyz + xy + z = xy(z + 1) + x = xy + x = x(y + 1) = x$$

We used the domination theorem  $z + 1 = 1$  and  $y + 1 = 1$  to simplify the expression.

**Example:** Simplify the following statement:  $xyz + x\bar{y}z + \bar{x}yz + \bar{x}\bar{y}z$

**Solution:**

**Example:** Simplify the expression,  $xyz + x\bar{y}z + \bar{x}yz + \bar{x}\bar{y}z$

**Answer:**  $xyz + x\bar{y}z + \bar{x}yz + \bar{x}\bar{y}z$

$$= xz(y + \bar{y}) + \bar{x}z(y + \bar{y})$$

$$= xz + \bar{x}z \text{ As } (y + \bar{y}) = 1$$

$$= z(x + \bar{x})$$

$$= z \text{ As } (x + \bar{x}) = 1$$

Later when we discuss the logic gates we will see that, we can use Boolean Algebra to simplify large and complex expressions into shorter and simpler versions. Which in turn makes the digital circuit a lot simpler.

### 3.7.2 Boolean Theorem

There are several boolean theorems mentioned in the previous table. Among these, the De Morgan's Theorem deserves some extra attention. We stated previously that in boolean algebra there are only three mathematical operations - complement, multiplication and addition. The De Morgan's theorem states that the summation of two variables complemented equals the multiplication of the complement of the same two variables. Simply put, we can express an addition operation with a multiplication operation

$$\overline{x + y} = \bar{x} \cdot \bar{y}$$

This theorem has a larger impact if we think hard. As this theorem suggests that using the complement one can express an addition operation as a multiplication operation, so we can say that the Boolean Algebra has only two basic operations - complement and multiplication.

Again, if we use the second De Morgan's theorem, we can replace any multiplication operation with addition operation using complements.

$$\overline{\bar{x} \cdot \bar{y}} = x + y$$

Similarly we can say that there are two basic operations in Boolean Algebra - complement and addition. We can conclude that in any way, Boolean Algebra has two basic operations. Either it is complement and multiplication or it is complement and addition.

**Example:** Express the domination theorem  $x + 1 = 1$  with multiplication.

**Solution:**

$$x + 1 = 1$$

Applying complement on both sides, we get

$$\overline{(x + 1)} = \bar{1}$$

Using De Morgan's theorem we can write:

$$\bar{x} \cdot \bar{1} = \bar{1} \text{ or } \bar{x} \cdot 0 = 0 \text{ as } \bar{1} = 0$$

Replacing  $x$  with  $y$  we get

$$y \cdot 0 = 0 \text{ which is the 2nd domination theorem.}$$

**Example:** Express the domination theorem  $x \cdot 0 = 0$  with multiplication.

**Solution:**

Applying complement on both sides, we get

$$(x \cdot 0) = 0$$

Using De Morgan's theorem we can write:

$$x + 0 = 0 \text{ or } x + 1 = 1 \text{ as } 0 = 1$$

Replacing x with y we get

$y + 1 = 1$  which is the 1st domination theorem.

De Morgan's theorem for more than two variables

De Morgan's theorem can also be applied for more than two variables and it will still remain true.

$$\overline{x_1 + x_2 + x_3 \dots x_n} = \bar{x}_1 \cdot \bar{x}_2 \cdot \bar{x}_3 \dots \bar{x}_n$$

$$\overline{x_1 \cdot x_2 \cdot x_3 \dots x_n} = \bar{x}_1 + \bar{x}_2 + \bar{x}_3 \dots \bar{x}_n$$

**Activity:** If  $\overline{x_1 + x_2} = \bar{x}_1 \cdot \bar{x}_2$  Prove that,  $\overline{x_1 + x_2 + x_3 \dots x_n} = \bar{x}_1 \cdot \bar{x}_2 \cdot \bar{x}_3 \dots \bar{x}_n$

**Hints:**  $\overline{x_1 + x_2 + x_3 \dots x_n} = \bar{x}_1 + (x_2 + x_3 \dots x_n) = \bar{x}_1 \cdot (x_2 + x_3 \dots x_n) = \dots$

**Activity:** If  $\overline{x_1 \cdot x_2} = \bar{x}_1 + \bar{x}_2$  Prove that,  $\overline{x_1 \cdot x_2 \cdot x_3 \dots x_n} = \bar{x}_1 + \bar{x}_2 + \bar{x}_3 \dots \bar{x}_n$

### 3.7.4 Truth Table

Complement, addition and multiplication - these three operations of Boolean algebra can be expressed through tables. If x and y are two boolean variables and as we know they can be either 0 or 1 so we can express every possible scenario of the three operations with a table in the following way.

x	$\bar{x}$
0	1
1	0

x	y	$x + y$
0	0	0
0	1	1
1	0	1
1	1	1

x	y	$x \cdot y$
0	0	0
0	1	0
1	0	0
1	1	1

If the relationship between every possible input and output is expressed through a table, then that table is known as the truth table. From the above example of truth table we can see that if there is only one variable, the truth table will have two input rows. If there are two variables, then the truth table will have 2<sup>2</sup> or 4 different input rows. So if there are n variables, there will be 2<sup>n</sup> different input combinations.

**Example:** Express the truth table for the following expression  $x \cdot ((y + z))$

**Solution:**

$x$	$y$	$z$	$(y + z)$	$\overline{(y + z)}$	$x \cdot \overline{(y + z)}$
0	0	0	0	1	0
0	0	1	1	0	0
0	1	0	1	0	0
0	1	1	1	0	0
1	0	0	0	1	1
1	0	1	1	0	0
1	1	0	1	0	0
1	1	1	1	0	0

### 3.7.5 Basic Gates - AND, OR, NOT gates

At the beginning of this chapter we mentioned that Boolean algebra is the base of digital electronics. In the following section we will see how it is so. There are different electronic gates to perform different Boolean operations. Gates are electronic devices that can express Boolean logic. We used two numbers (0,1) to express Boolean algebra. Digital electronics uses two different voltages for this. Depending on the use, many different voltages are defined for different type of works.

The three operations of boolean algebra are performed by three different logic gates. These are depicted in Figure 3.2. The Complement operation is performed by the NOT gate, multiplication operation is performed by the AND gate and addition operation is performed by the OR gate. If we look at the truth table we created to express the three operations we will begin to understand the reason behind the naming of the gates. NOT gate reverses an input. To get a 1 output from the AND gate, both inputs have to be 1. If any of the input is 1, the OR gate has 1 output. These three gates are called basic gates as we can build any complex digital circuits using these three gates.

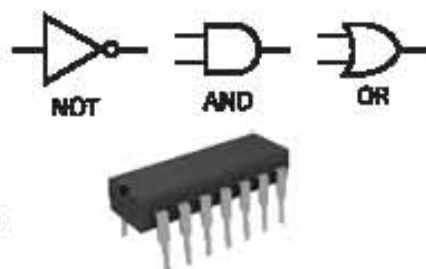

Figure 3.2: Symbol of NOT, AND and OR gate and a digital logic gate

Although we are discussing only two inputs, there are AND and OR gates which support more than two inputs. We can even create more than two input logic gates by using the basic two input gates.

Let us learn how to build different circuits using the basic three gates.

**Example:** What will be the output of the following circuit if both inputs are 1? What will the output look like if we express the input by  $x$  and  $y$  variables?



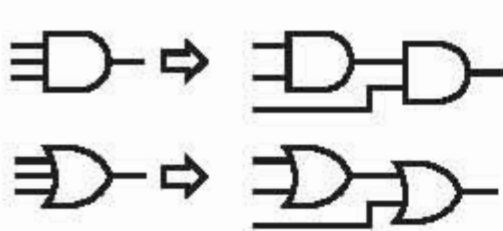

Figure 3.3: 3 input AND gate and OR gate

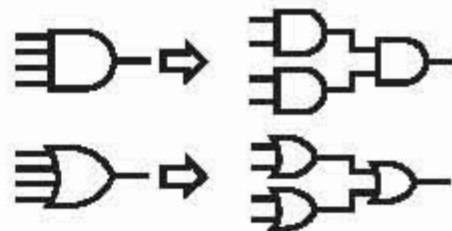
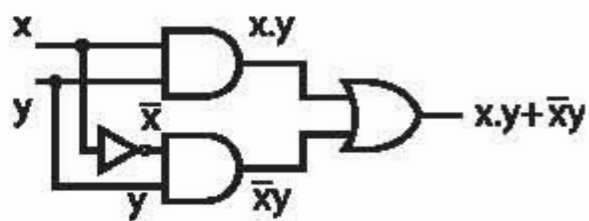
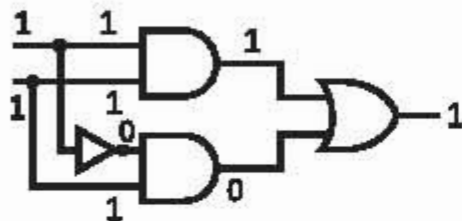
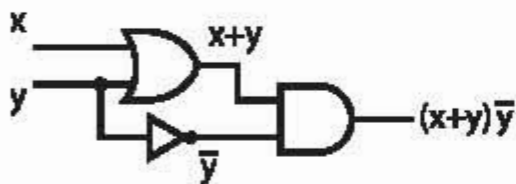

Figure 3.4: 4 input AND and OR gate

**Example:** Draw the circuit for the following expression  $(x + y).y$  What will be the output if  $x=1$  and  $y=0$ ?



$$(x + y)\bar{y} = (1 + 0)\bar{0} = 1.1 = 1$$



**Example:** Draw the circuit for the following expression  $\bar{x}((y + z))$  What will be the output if  $x=1$ ,  $y=0$  and  $z=1$ ?

**Solution:**  $\bar{x}(y+z) = \bar{1}(0+1) = 0(0+0) = 0$

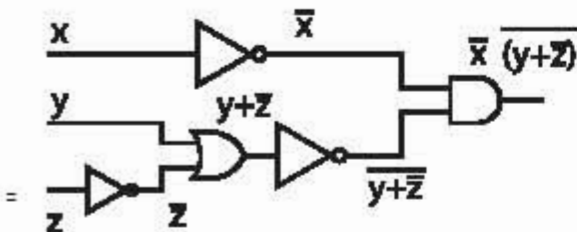

**Example:** Make a truth table for the following expression  $x((y + z))$

**Solution:**

$x$	$y$	$z$	$\bar{x}$	$\bar{z}$	$(y + \bar{z})$	$\overline{(y + \bar{z})}$	$\bar{x} \cdot \overline{(y + \bar{z})}$
0	0	0	1	1	1	0	0
0	0	1	1	0	0	1	1
0	1	0	1	1	1	0	0
0	1	1	1	0	1	0	0
1	0	0	0	1	1	0	0
1	0	1	0	0	0	1	0
1	1	0	0	1	1	0	0
1	1	1	0	0	1	0	0

**Example:** Build a circuit which will simulate a voting system where if two out of three people vote 'yes' then yes will be counted as winner.

**Solution:**

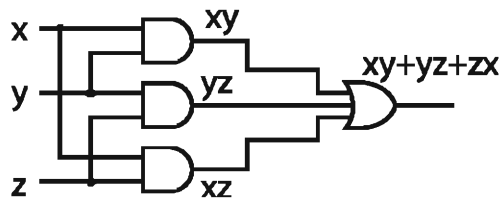

**Example:** Assume that you want to control a light bulb with two different switches. So if the light is on, turning off any one of the switches will turn the light off. If the light is off then turning on any one of the switches will turn the light on.

**Solution:** Let us assume that the two switches are the inputs of a circuit  $x$  and  $y$ . If the values of  $x$  or  $y$  is 1 then that switch is on and if it is 0 then the switch is turned off. As there are two variables we will have 4 different input combinations for output  $Q$ .  $Q$  denotes the state of the light bulb, if  $Q = 1$  then the light is on and if  $Q = 0$  then the light is off. There can be a state where both switches are off but the light is on, so  $x=0, y=0$  and  $Q=1$ . This will be the first row of or truth table. From this state if we want to flip any of the switches on then the light should turn off so for  $x=1, y=0$  and  $x=0, y=1$  the value of  $Q$  will be 0. For the last row of the truth table,  $x$  and  $y$  both should be 1. To get to this state we have to flip one switch from  $x=1, y=0$  or  $x=0, y=1$  state which will turn the  $Q=1$  again. So the circuit will look like the following figure.

x	y	Q
0	0	1
0	1	0
1	0	0
1	1	1

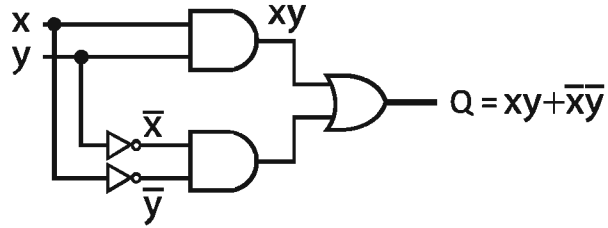

Figure 3.5: Truth Table and Circuit Diagram of a Light Control System

### 3.7.6 Universal Gate

Before we get into universal gates, let's start with NAND and NOR gates. From the name we can guess that NAND is a NOT AND gate or there is a NOT on the output of an AND gate. Figure 3.6 describes a NAND gate's truth table, sign and logical form. Similarly a NOR gate is an OR gate that has a NOT to its output.

We have already known that Boolean algebra has three operations - multiplication, addition and complement. From De Morgan's theorem we came to know that we can do any kind of Boolean operations using only complement and addition operation or complement and multiplication operation. So we can safely say that any digital electronics circuit can be built using only two types of logic gates. These gates are either NOT and AND or NOT and OR. As NOT and AND is basically NAND gate and NOT and OR gate is NOR gate to NAND and NOR gates are called universal gates.

The following figure demonstrates how a NAND gate can be used to make a NOT gate and a logical AND gate. Similarly the next figure demonstrates how a NOR gate can be used to make a NOT gate and an OR gate.

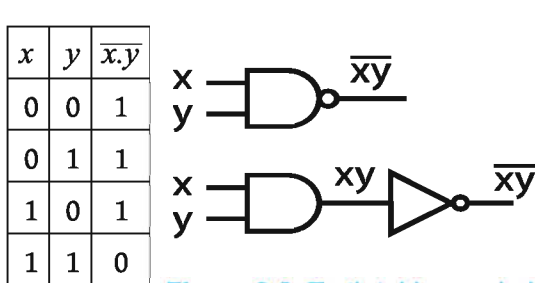

Figure 3.6: Truth table, symbol and Logic gate of a NAND gate

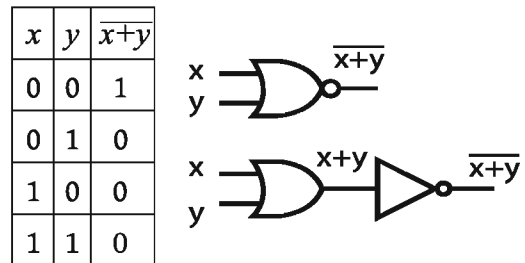

Figure 3.7: Truth table, symbol and Logic gate of a NOR gate

Now let's see how we can make a OR gate out of a NAND gate and an AND gate out of a NOR gate.

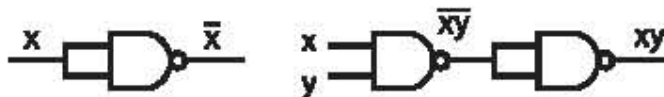

Figure 3.8: Logical NOT gate and Logical AND gate

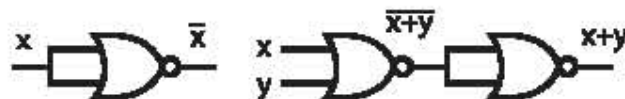

Figure 3.9: Logical NOT gate and Logical OR gate

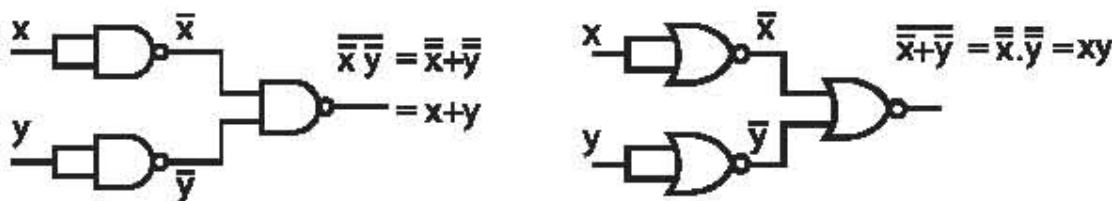

Figure 3.10: Making a OR gate with NAND gates and making an AND gate with NOR gates

**Example:** Make a circuit out of the expression  $x.y + \bar{x} .y$  using only NAND and NOR gates

**Solution:**

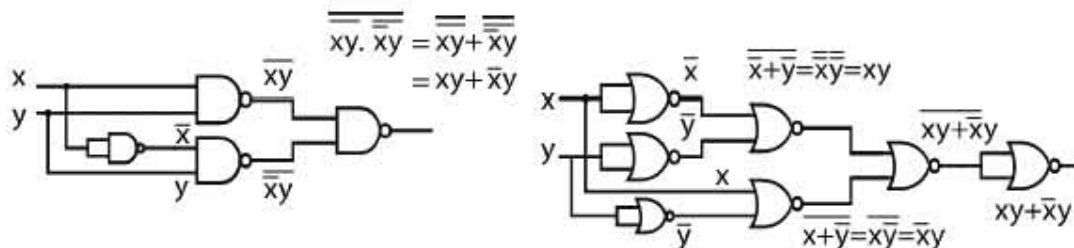
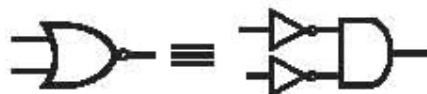

Figure 3.11: A complete circuit built with only NAND gates and same circuit with only NOR gates



**Do it yourself:**

The following figure refers to which boolean theorem?

### 3.7.7 Special Gates XOR and XNOR

Digital electronics circuits demand addition operation on binary numbers. 1 bit binary addition looks like this:

$$\begin{array}{r} 0 \quad 0 \quad 1 \quad 1 \\ +0 \quad +1 \quad +0 \quad +1 \\ \hline 0 \quad 1 \quad 1 \quad 10 \end{array}$$

When we are adding 1 and 1, we have a two bit binary number as a result. Here the right bit is our result and the left bit is called carry. Let us put our mind off the carry bit and discuss the result bit. In Boolean algebra we have seen that adding 1 and 1 gets us 1 as a result not 0. So the AND gate which we use for Boolean addition operations cannot be used to add binary numbers. To perform binary addition we use a special gate Exclusive or or more commonly known as XOR gate. The truth table, symbol and logic of the XOR gate is shown in the figure. Simply put if there are two different inputs then XOR will produce a 1 output, otherwise it will be a 0 output. The expression of an XOR gate is  $xy + x \cdot y$

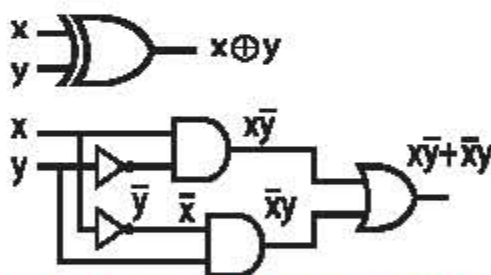

Truth table of XOR gate

x	y	$x \oplus y$
0	0	0
0	1	1
1	0	1
1	1	0

Figure 3.12: Truth table, symbol and logic of XOR gate

Separate XOR gates are available to be used in digital electronics circuits. But we can make an XOR gate out of the basic gates if we want.

Any gate must have its NOT form too so XNOR gate is used quite regularly too. It can be made by putting a NOT gate on the output of an XOR gate. One can also make the XNOR gate using the logic shown in the figure.

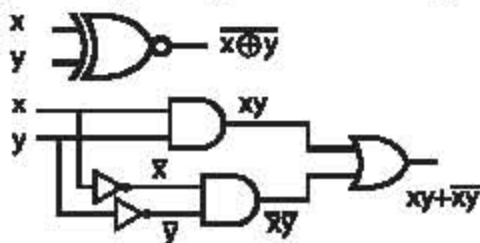

x	y	$\overline{x \oplus y}$
0	0	1
0	1	0
1	0	0
1	1	1

Figure 3.13: Truth table, symbol and logic of XNOR gate

As NAND and NOR are universal gates, we can build an XOR or XNOR gate using only NAND and NOR gates. We have already demonstrated how we can make XOR or XNOR gates from basic gates. Let us see how we can do it with NAND and NOR gates.

**Example:** Make XOR gate using only NAND and NOR gates

**Solution:**

From De Morgan's theorem we can write:

$$xy + x \cdot y = (((xy + x \cdot y))) = (((x \cdot y))) + (((\cdot x \cdot y))) = (x + y) + (x + y)$$

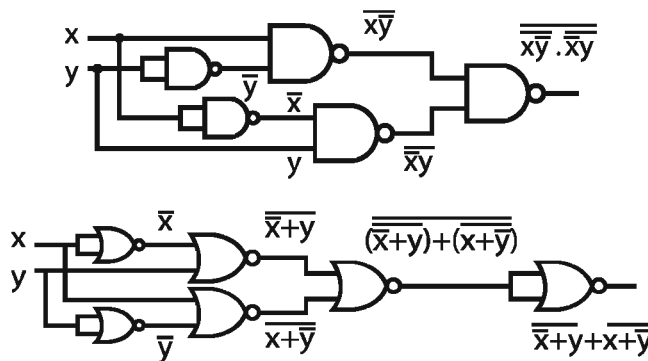

Figure 3.14: XOR circuit built with only NAND and NOR gates

**Example:** Make XNOR gate using NAND and NOR gates

**Solution:**

$$xy + \underline{x} \cdot \underline{y} = \underline{\underline{(xy + x \cdot y)}} = \underline{\underline{xyx \cdot y}}$$

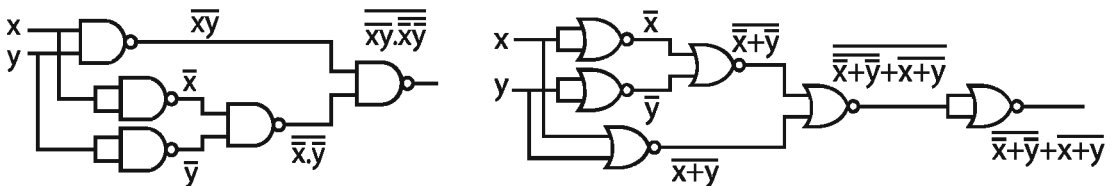

Figure 3.15: XNOR circuit built with only NAND and NOR gates

### 3.7.8 Encoder

We have discussed different types of gates and logics used in digital electronics. Now let us delve into the different circuits we can build using these logic gates. Although in our day to day life we do not need to build circuits from scratch using only basic gates. All of them comes to us as integrated circuit form.

Encoder and Decoder are two very well known digital circuits. An Encoder has multiple input lines and any one of these input lines are made alive with an input signal 1, so the rest of the input signals are 0 at that moment. Encoder output gives us the line number of the live signal in binary form. Let us say an Encoder has 8 input lines from A0 to A7 To know which line has the signal we need three output lines O0 , O1 and O2 . First let us make the truth table for this 8 input and 3 output encoder.

Input								Output		
A <sub>0</sub>	A <sub>1</sub>	A <sub>2</sub>	A <sub>3</sub>	A <sub>4</sub>	A <sub>5</sub>	A <sub>6</sub>	A <sub>7</sub>	Q <sub>2</sub>	Q <sub>1</sub>	Q <sub>0</sub>
1	0	0	0	0	0	0	0	0	0	0
0	1	0	0	0	0	0	0	0	0	1
0	0	1	0	0	0	0	0	0	1	0
0	0	0	1	0	0	0	0	0	1	1
0	0	0	0	1	0	0	0	1	0	0
0	0	0	0	0	1	0	0	1	0	1
0	0	0	0	0	0	1	0	1	1	0
0	0	0	0	0	0	0	1	1	1	1

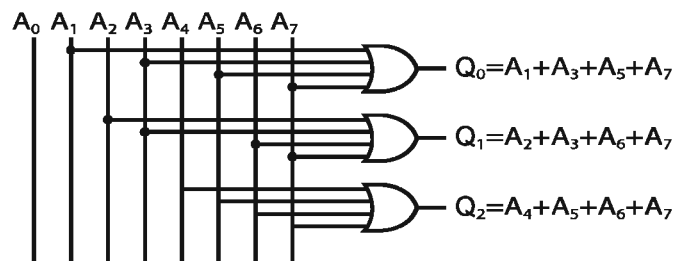

Figure 3.16: Truth table and circuit for an Encoder

So in this encoder if we send our signal to A2 input line we will get 010 or 2 as output. Similarly if we have the signal on A5 line the output will be 101 or 5.

IF we first make the truth table then designing the rest of the circuit is very easy. From the truth table we can see that to get the value 1 in O0 line, any one of the A1, A3, A5 and A7 lines need to have 1. So we can connect A1, A3, A5 and A7 lines to an OR gate and the output will be O0. Likewise O1 will be 1 when any of the A2, A3, A6 and A7 lines are one. So we connect them in an OR gate and the output is O1. Similarly connecting A4, A5, A6 and A7 through an OR gate will give us O2.

As you can see we can very easily make a 8 input and 3 output encoder circuit. You can build and test this circuit and see if it produces the desired results.

**Problem:** From the figure we can see that we have built the circuit without ever using the A<sub>0</sub> line. How is this possible?

### 3.7.9 Decoder

Decoder acts as a reverse of the encoder circuit. If a binary number is put into a decoder input, the corresponding output line will get a 1 signal. First let us observe the truth table of the decoder circuit. Referring to our previous example of an encoder, we will make a 3 input and 8 output decoder circuit. The truth table has the three input lines A<sub>0</sub>,A<sub>1</sub>,A<sub>2</sub> and 8 output lines Q<sub>0</sub>,Q<sub>1</sub>,Q<sub>2</sub>,Q<sub>3</sub>,Q<sub>4</sub>,Q<sub>5</sub>, Q<sub>6</sub>,Q<sub>7</sub>

(True table of decoders)

Input			Output							
A <sub>2</sub>	A <sub>1</sub>	A <sub>0</sub>	Q <sub>0</sub>	Q <sub>1</sub>	Q <sub>2</sub>	Q <sub>3</sub>	Q <sub>4</sub>	Q <sub>5</sub>	Q <sub>6</sub>	Q <sub>7</sub>
0	0	0	1	0	0	0	0	0	0	0
0	0	1	0	1	0	0	0	0	0	0
0	1	0	0	0	1	0	0	0	0	0
0	1	1	0	0	0	1	0	0	0	0
1	0	0	0	0	0	0	1	0	0	0
1	0	1	0	0	0	0	0	1	0	0
1	1	0	0	0	0	0	0	0	1	0
1	1	1	0	0	0	0	0	0	0	1

To make a decoder circuit we first have to look at the truth table, and we can

see that we have to use 8 AND gates that can take 3 inputs. The circuit and truth table are shown in the following figure. We can see that every output of the decoder circuit is a combination of AND logic with A<sub>0</sub>,A<sub>1</sub>,A<sub>2</sub> and one or more NOT gates to them. For example we know that if A<sub>0</sub>,A<sub>1</sub>,A<sub>2</sub> inputs are 0 the output O0 should be 0. But we know that three 0 inputs will not produce a 1 output in an AND gate. To get a 1 output all the inputs need to be 1. So we put a not gate on each input line of A<sub>0</sub>,A<sub>1</sub>,A<sub>2</sub> and will get a 1 from the AND gate. Likewise for other outputs, as we are using AND gates we need all inputs to be 1. So to make an input 1 we need to use NOT gates as necessary.



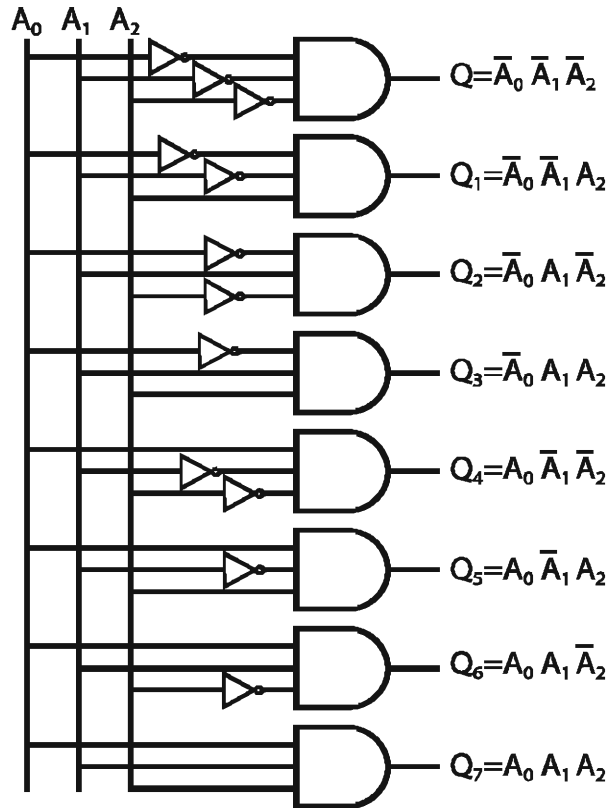

Figure 3.17: Truth table and required circuit for a Decoder

### 3.7.10 Adder

Adder is another circuit made out of logic gates that can perform addition operation on binary numbers. We already know that if we have a circuit that can perform binary addition operation, then that circuit can be used to do subtraction, multiplication and division operation too.

While discussing the XOR logic gate we explained that during a binary addition operation like  $1 + 1 = 10$ , the rightmost bit is the result bit and the leftmost bit is the carry bit. We know we can get the result bit through an XOR logic gate, but how do we get the carry bit? Very simple we can get the carry bit with an AND gate. So the truth table and the circuit diagram of the adder circuit will look like this on the following figure.

$x$	$y$	$S$	$C$
0	0	0	0
0	1	1	0
1	0	1	0
1	1	0	1

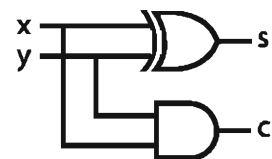

Figure 3.18: Truth table and required circuit for a Half Adder

This type of circuit is called a Half Adder Circuit because it can not perform a full binary addition operation. If we have a carry bit from the previous step the Half Adder Circuit can not process it. In regular binary addition, when we are adding two bits then we must take into account the carry bit carrying over from the addition of the previous two bits. So actually in those cases we are adding three bits. An example is shown below

$$\begin{array}{r} \downarrow \downarrow \quad \downarrow \\ 1001101 \\ 1011001 \\ \hline 10100110 \end{array}$$

The arrows denote the bit positions where we have a carry from the addition of previous two bits. We can rephrase this as, we are adding three bits every time but sometimes the carry bit is 0 and sometimes the carry bit is 1. Let us write a truth table for three bits x, y and C<sub>IN</sub>. Here x and y are the two bits of the numbers to add and C<sub>IN</sub> is the carry bit carried over from the previous two bit addition. There are two outputs in the truth table S and C<sub>OUT</sub>. S is the sum of bits x and y and C<sub>OUT</sub> is the carry bit that will act as C<sub>IN</sub> for the next step.

**Table 3.6**

Input			Output	
x	y	C <sub>IN</sub>	S	C <sub>OUT</sub>
0	0	0	0	0
0	1	0	1	0
1	0	0	1	0
1	1	0	0	1
0	0	1	1	0
0	1	1	0	1
1	0	1	0	1
1	1	1	1	1

From the truth table we can see that from 8 possible combinations of input of x, y and C<sub>IN</sub>, in four cases the output S and C<sub>OUT</sub> will be 1. Like in the decoder circuit we will apply the same methodology to use NOT gates and AND gates to get the 1 output when needed. The Figure 3.19 depicts the Full Binary Adder Circuit. OR gates are used to combine the outputs for S and C<sub>OUT</sub>. You will notice that though they have the same logic, while the OR gate of S uses 4 inputs we can derive a C<sub>OUT</sub> from 3 inputs. For S output the expression will be

$$S = \bar{x}y\bar{C}_{IN} + x\bar{y}\bar{C}_{IN} + \bar{x}yC_{IN} + xyC_{IN}$$

Likewise for C<sub>OUT</sub> the expression is

$$C_{OUT} = xy\bar{C}_{IN} + \bar{x}yC_{IN} + x\bar{y}C_{IN} + xyC_{IN}$$

Simplifying this we get the following expression.

The simplification process is explained in the following example.

$$C_{OUT} = xy + yC_{IN} + xC_{IN}$$

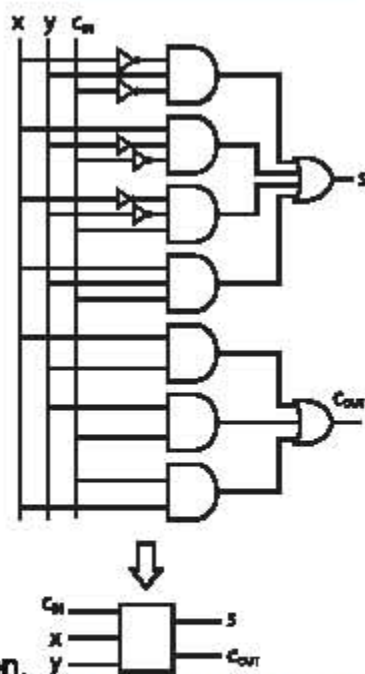

Figure 3.19: Truth table and required circuit with block diagram for a Full Adder

**Example:** Simplify the  $C_{OUT}$  initial expression

**Solution:**

As we know that  $A + A = A$  so we can add the last  $xyC_{IN}$  to the other three terms and get

$$C_{OUT} = (xy\overline{C_{IN}} + xyC_{IN}) + (\bar{x}yC_{IN} + xyC_{IN}) + (x\bar{y}C_{IN} + xyC_{IN})$$

$$C_{OUT} = xy(\overline{C_{IN}} + C_{IN}) + yC_{IN}(\bar{x} + x) + xC_{IN}(\bar{y} + y)$$

As we know,  $A + \underline{A} = 1$  so we can get

$$C_{OUT} = xy + yC_{IN} + xC_{IN}$$

This circuit which adds two binary bits is called a full Adder Circuit. But in real life scenarios we have to add a lot more than two bits so to make life easier for us we represent the whole full Adder Circuit as a block diagram where only the input and output lines are shown. To get a 4 bit full Adder Circuit we have to add 3 full adder circuits with one another. This is shown in the figure.

You will notice that in the first block the  $C_{IN}$  input is by default 0 as this is the first bit and no bit can carry over to this. Also to display the proper result of a 4 bit adder we need 5 bits so the last  $C_{OUT}$  output is part of the result.

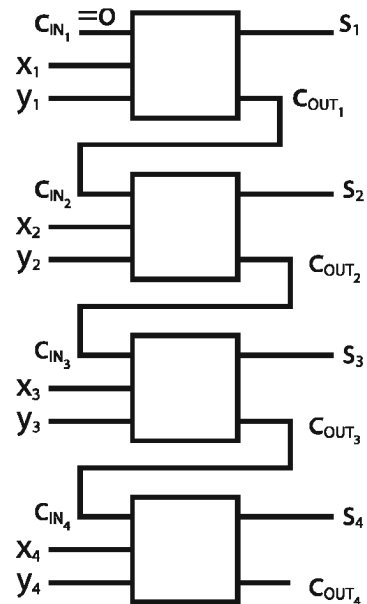

**Figure 3.20:** Block diagram of a 4 bit Adder Circuit

### 3.7.11 Register

The circuits we have worked on so far has a principle. As long as we have an input signal we can get proper output signals, otherwise we do not have an output. But we have situations when we need to store a value in our circuit, which we call the memory. The circuit we are going to discuss now can take an input and store that input for later use. These types of circuits are known as flip flops. Figure 3.21 demonstrates a flip flop circuit and its truth table. Here  $Q$  is the output and another output  $\bar{Q}$  is its complement.

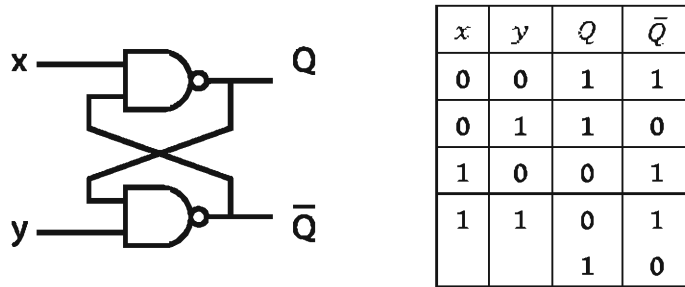

Figure 3.21: Truth table and circuit for a Flip Flop

Let us figure out the truth table of the flip flop circuit. We know that in NAND gates if any one of the input is 0 then the output is 1. So if both the x and y input are 0 then the output of the two NAND gates here Q and  $\bar{Q}$  are 1. But as Q is the complement of  $\bar{Q}$  so both of them can not be of the same value. So we will assume that x and y both will never be 0 in this circuit, this will not be an acceptable input. If the input is x=0 and y=1 then reasonably we will get 1 and 0 in  $\bar{Q}$  and Q outputs. Likewise if x=1 and y=0 then we will get 0 and 1 in  $\bar{Q}$  and Q outputs.

What happens when x and y both are 1? This is an interesting scenario as in this case the outputs Q and  $\bar{Q}$  can be both 1 and 0 or 0 and 1. But this is no mathematical theory, this is a real life digital circuit, so which output will we get?

The answer is simple if you think. The output will depend on the previous state of x and y. If the previous state was x=0 and y=1 then when x=1 and y=1 is put into input lines we will get Q =1 and  $\bar{Q}$  = 0. And if the previous state is x=1 and y=0 then we will get Q=0 and  $\bar{Q}$ =1. This can be put into truth table like this

	x	y	Q	$\bar{Q}$
↓	1	0	0	1
	1	1	0	1

	x	y	Q	$\bar{Q}$
↓	0	1	1	0
	1	1	1	0

We can now say that, by turning both x and y input to one, we have stored the x value in Q and y value inside  $\bar{Q}$ . So the general rule of thumb of using the flip flop circuit is, keeping the input lines to 1 all the time except when we need to store a bit. If x is made 0 then Q will be 1 and if y is made 0 then  $\bar{Q}$  will be 0.

How this is accomplished is demonstrated in the figure 3.22 circuit. We see that the input D is put through two extra NAND gates instead of directly putting into the input lines of the flip flop circuit. The bottom NAND gate has an inverter before it ensures that x and y always get different values. But as long as the CLK input is 0 the D input

can not reach the input lines of the flip flop circuit. Irrespective of what is in the D input, if CLK is 0 then both x and y will have 1 value. To store the D input into the flip flop the CLK input is turned to momentarily and then again it is turned back to 0.

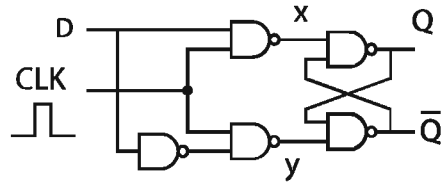

Figure 3.22: DQ Flip Flop circuit

Let us assume that we put  $D = 1$  and for a moment we turn the CLK signal to 1 (which is known as a CLK pulse in digital electronics). During the pulse x will be 0 and y will be 1, so ! will be 1 and Q will be 0. After the pulse CLK will be 0 again turning both x and y both to 1 thus storing the D value into Q. Similarly if we load the 0 value into D and send a CLK pulse, after the pulse the 0 value will be stored into Q.

This is called a DQ flip flop circuit. 3.23 figure explains this circuit. To simplify the circuit we haven't shown the Q. To make it brief, with this circuit the value of D can be stored into Q with a pulse. If we change the value of D after that Q will be the same unless we again put a pulse. To remove any confusion about this concept, DQ flip flop circuits will be used in the rest of the circuits of this chapter.

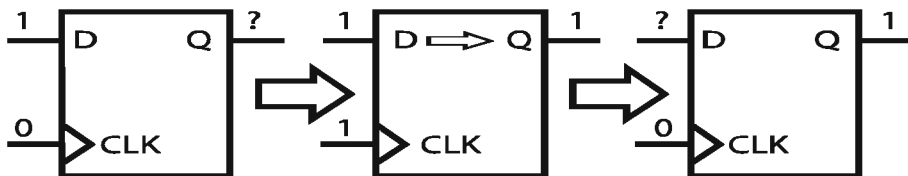
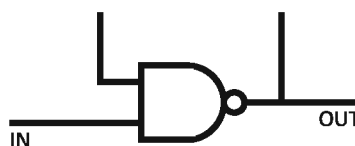

Figure 3.23: The process for how 1 is loaded from D to Q. At the beginning D has 1 but Q remains unchanged. The Clock pulse in the next step transfers D's value into Q. At the final step CLK is 0 so whatever value is in D would not change the value of Q.

Do it yourself: Make a flip flop circuit using two NOR gates instead of two NAND gates. Draw a truth table for the circuit

Do it yourself: What will be the output of the circuit in the following figure if the input is 0?



**Parallel Load Register**

The 3.24 figure shows a circuit made with four DQ flip flops. As all four flip flops are using the same CLK signal so this circuit will be able to store 4 bits of information. Putting 4 bits to A0, A1, A2, A3 input lines and sending a CLK pulse will store them inside I0, I1, I2, I3. After this if anyone changes the value of any or all of the inputs the output will remain the same. The only way to change the output is to change the input and send a CLK pulse. We can increase the number of flip flops to store upto 1 or multiple bytes of information. These types of circuits are called parallel load registers.

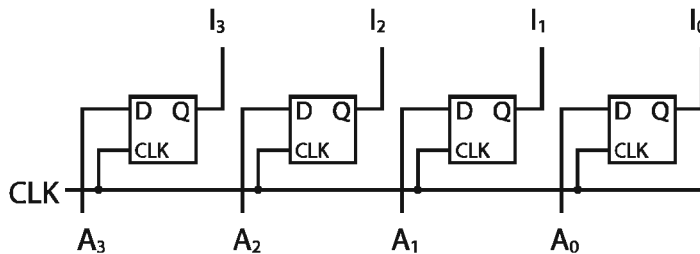

Figure 3.24: Parallel Load Register

**Shift Register**

In parallel load registers all of the input signals are sent to output parallelly with a single clock pulse. There is a different kind of register in which one flip flops output Q is connected to the next flip flops input D. Each clock pulse shifts one flip flops input into the next flip flop. These types of circuits are known as shift registers. Shift registers get serial data as input and produce parallel data as output. Figure 3.25 shows a shift register circuit.

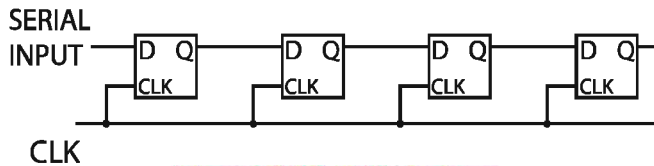

Figure 3.25: Shift Register

**3.7.12 Counter**

Counter is a type of digital circuit that can count. We can use DQ flip flops to make Counter circuits. We know that flip flops have two outputs Q and  $\bar{Q}$  but as we did not need the  $\bar{Q}$  output for register circuits we did not show them in figure. To build a counter circuit we will need both Q and  $\bar{Q}$  outputs from the flip flops. A very simple counter circuit is shown in figure 3.26.

The interesting part here is, we are not providing CLK pulse to every flip flop. Only the first flip flop will receive the real CLK pulse, the rest of the flip flops will have the previous ! output as their CLK pulse.

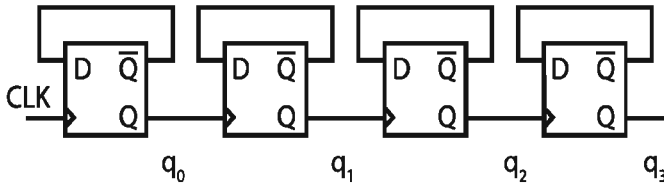

Figure 3.26: Ripple Counter

To use the counter initially all the Q outputs of flip flops in the counter circuit should be set to 0. So all the  $\bar{Q}$  will have 1 value. So with each CLK pulse Q value will be set into Q through D input.

As the complement of the D value is loaded into Q so in the first flip flop, the value of Q will be toggled between 0 and 1 with each pulse. The truth table will provide a better explanation. The same thing will happen to all the next flip flops. But as Q0 is used as the clock of Q1 so the second flip flops output will toggle after the two CLK pulses. Likewise the next flip flop will toggle after 4 pulses.

We put q0 in the rightmost column of the table and put the rest accordingly because looking at the table we can see that q3, q2, q1, q0 are actually the output of the counter circuit that is counting the clock pulse in binary numbers. This type of counter is known as a ripple counter.

There are many different types of counter circuits that can count differently too.

**Do it yourself:** In the following figure the value of Q1,, Q2 and Q3 are 0, 1 and 1. What will be the value of Q1,, Q2 and Q3 after 3 clock pulses?

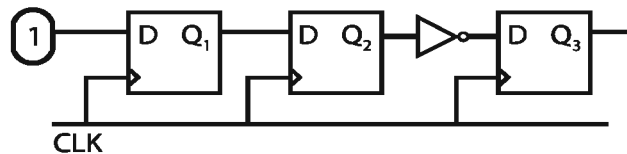

**Table 3.7**

CLK Number of pulses	q <sub>3</sub>	q <sub>2</sub>	q <sub>1</sub>	q <sub>0</sub>
0	0	0	0	0
1	0	0	0	1
2	0	0	1	0
3	0	0	1	1
4	0	1	0	0
5	0	1	0	1
6	0	1	1	0
7	0	1	1	1
8	1	0	0	0
9	1	0	0	1
10	1	0	1	0
11	1	0	1	1

### Exercise

#### MCQ

- Unicode has -
  - 4 bits
  - 16 bits
  - 8 bits
  - 32 bits
- How many different characters can be encoded in Unicode?
  - 4
  - 16
  - 256
  - 65536
- 4, 8, C what is the next number of this series?
  - D
  - F
  - 10
  - 16
- What is the 2's complement of the decimal number -12?
  - 00001100
  - 11111100
  - 11110011
  - 11110100
- What is the Hexadecimal form of binary number 111011?
  - E3
  - E8
  - EC
  - CE
- If a gate has every input line as 0 and the output is 1, the gate is a -
  - NAND
  - NOR
  - OR

Which one is true?

  - i and ii
  - i and iii
  - ii and iii
  - i, ii and iii

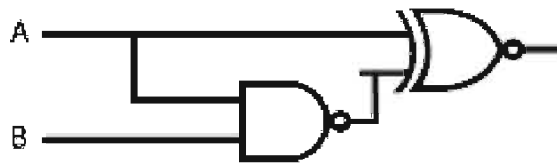

See the figure and answer the questions no 7 & 8:

- What is the value of F?
  - $AB$
  - $A\bar{B}$
  - $\bar{A}B$
  - $\bar{A}\bar{B}$
- Which gate here will produce 0 output?
  - AND
  - NAND
  - OR
  - NOR
- $(110110)_2 = ?$ 
  - $(66)_8$
  - $(54)_{10}$
  - $(36)_{16}$

Which one is true?

  - i and ii
  - i and iii
  - ii and iii
  - i, ii and iii



**Creative Questions**

1.

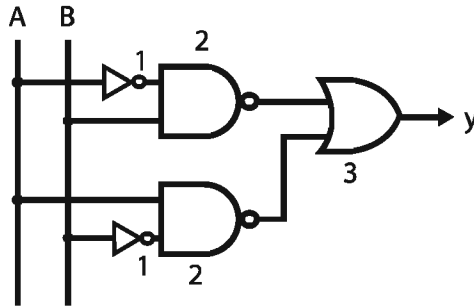

- a. What is 2's complement?
- b. Binary 1+1 and Boolean 1+1 are not the same, explain.
- c. From the figure, get the simplified value for y.
- d. The gates marked 2 and 3 in the figure can be exchanged between themselves to create a binary adder circuit. Explain.

2. X, Y and Z went to the market and bought three books with the price of  $X = (110110)_2$ ,  $Y = (36)_8$  and  $Z = (A9)_{16}$  taka.

- a. What is code?
- b. Why do we need 2's complement? Explain.
- c. Find the price of Z in the decimal system.
- d. X buy higher price books then Y analysis by using 2's complement method.

3.

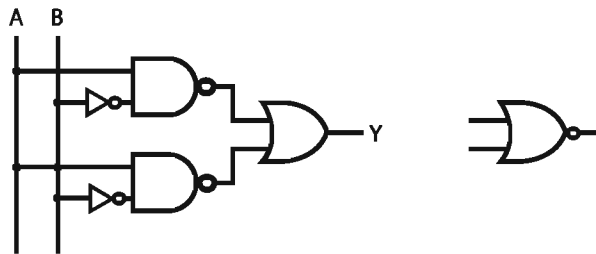

Figure-1

Figure-2

- a. What is an adder?
- b.  $M(M+M) = M$ , explain.
- c. Write a truth table for the gate in figure 2.
- d. Can the figure 2 gate be used to make a similar circuit as in figure 1? Explain with logic.

4. The ICT teacher said in one of his classes, a computer can not recognize the letter A. It has to be transformed into a special 8bit code with the help of a logic circuit. He also said that the same coding mechanism will not work for Bangla letters, you will need a different coding system for that.
- What is a decoder?
  - Describe the characteristics of a shift register.
  - Describe the circuit in the passage.
  - Which of the 2 coding mechanisms described in the passage is easier to use? Explain with logic.

5.

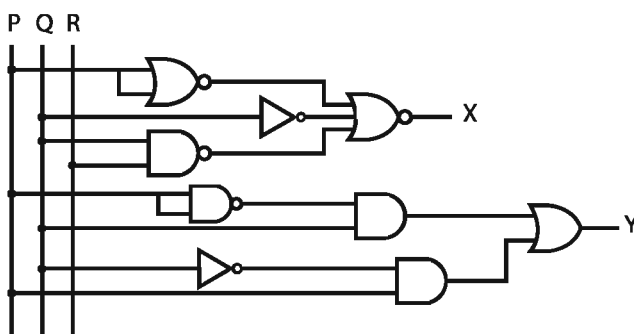

- What is a counter?
- If all the inputs of a NOR gate are the same, it acts as a basic gate. Explain.
- Use a truth table to define Y's value.
- Use the simplified value of X to show that it can be more easily implemented using a NOR gate.



## 4.1 Concept of Web Design

---

In the first age of computers, only the largest universities, laboratories and important government organizations like the defence or the military had access to computers. These computers were used only for processing data, crunching numbers, evaluating research results and such works. The need to connect a computer to another was soon realized and thus with that demand we saw the birth of the internet. The demand of transferring files from one computer to another made Tim Berners-Lee create the World Wide Web. He was working at CERN at that time, a famous research institute situated in Switzerland. In 1989, he proposed a concept where using IP addresses a computer can send documents to another computer. Tim thought, using this way researchers from around the world can easily share their research findings and compare notes on each other's works. His proposed system described a way so that researchers do not have to download a thousand page document but can view the document from the internet. Each page will be linked with another important page related to that. So a user can only download the pages he or she needs. He named these written texts on the internet as Hypertexts. The network addresses in which these hypertexts will be found were called Hyperlinks. Information on the internet which are in media format like photo, video or audio were called Hypermedia. Tim thought of a system where users can get the hypertexts from the hyperlinks with just a click of the mouse. In 1990, with the help of his co-workers he proposed a more detailed solution to this. He made a separate software to view these web documents from another computer. He called the software a web browser.

These are the concepts upon which the modern web was built. There are countless websites on the internet at present. We visit and browse these websites using different softwares. These softwares are known as web browsers. Mozilla Firefox, Google Chrome, Safari, Internet Explorer, Microsoft Edge are some popular web browsers. In the past most websites were static. They had static information that users can view through web browsers. But now almost all websites are dynamic, in the sense that they produce different outputs depending on the user inputs. These are also known as web applications. Google.com, services.nidw.gov.bd, passport.gov.bd are some examples of such web applications.

Every website has two sides, server and client. The client software collects data or input from the user and sends the data to the server. This action is known as a Request. Server software analyzes the data and produces the desired output and sends it to the client, which is known as a 'Response'. For example, when a user wants

to create a user account on a website, they input the necessary information to a browser and clicks a button. That button click sends the form data to the server which processes the data for errors and duplicity. If there is no problem in the processing, the server creates the account and sends a success response to the client. If there are problems, the server may send error responses to the client.

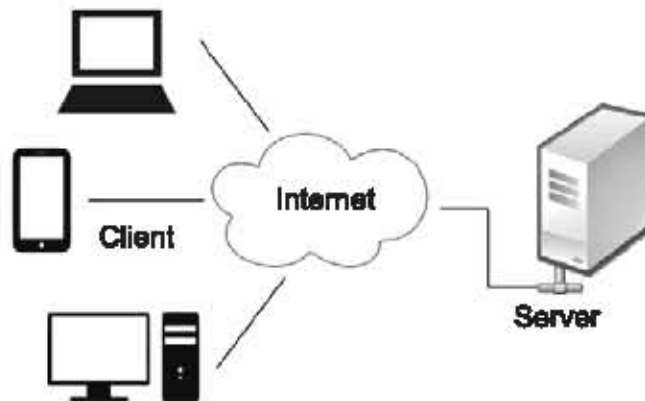

**Figure 4.1: Server and clients connected through the Internet**

The server softwares is generally written in a programming language. PHP, Python, Ruby, Java are some popular languages for these kinds of works.

The web applications run in web browsers use HTML and CSS. The full form of HTML is Hyper Text Markup Language. HTML is a markup language, not a programming language. HTML makes the information in a website or a web application readable through a browser. A web browser knows the HTML tags and purses them to display the information properly as intended.

Although you can create a website with only HTML, you will need CSS or Cascading Style Sheet to make it look good. All modern websites use the CSS in conjunction with the HTML.

It is not necessary that a web application has to send data to the server side for processing. Some tasks can be processed at the client end. Client end processing is very popular nowadays. Javascript is a popular language for this type of work.

### 4.1.1 Website Structure

A website can have one or more web pages. The first page of a website is called the Homepage. Different types of websites contain different types of pages depending on their utility. An audio/video sharing website will have a page for streaming audio/video. Most websites have a user profile page which shows the user information. Blog sites have separate pages for each blog post. Some pages are very common and can be seen in almost every website, like the 'Contact Us' page, 'About Us' page or the FAQ page.

## 4.2 HTML Basics

---

The 4.2 section of this chapter is a practical section. This section is meaningful only in an environment where the students have the facilities to write programming codes.

To work with HTML first we need to create a file with the extension .html. We can name the file anything as we please, like mypage.html. If we open the file with a web browser we will see a blank page because we haven't written anything in it yet. To edit an HTML file, we can use any text editors. Notepad, Notepad++, sublime text are popular text editors in this line of work.

### HTML Element

A book can have several parts and each part can contain several chapters. Each chapter can contain headings, subheadings, lists and paragraphs. A book can contain images, captions, tables and lists. Similarly an HTML page can have different elements like in a book. These are called HTML elements.

Tags are used to write html elements. Tags are similar to brackets. Each html element has an opening and a closing tag. Opening and closing tags and the content in between comprises to make an html element. Some elements do not have any contents inside them so they do not need a closing tag. These are called empty elements.

A tag is named after the element's name or part of the element's name. Opening and closing tags of an element looks like this - <element\_name> and </element\_name>. Opening tags are enclosed between two angle brackets, while the closing tags have a forward slash in front of the name. Both opening and closing tags should have the same name inside them.

**A sample html code looks like this:**

```
<!DOCTYPE html>
<html>
<body>
Hello World!
</body>
</html>
```

If we type and save this code in an html file, it will look like this after opening the file in a web browser.

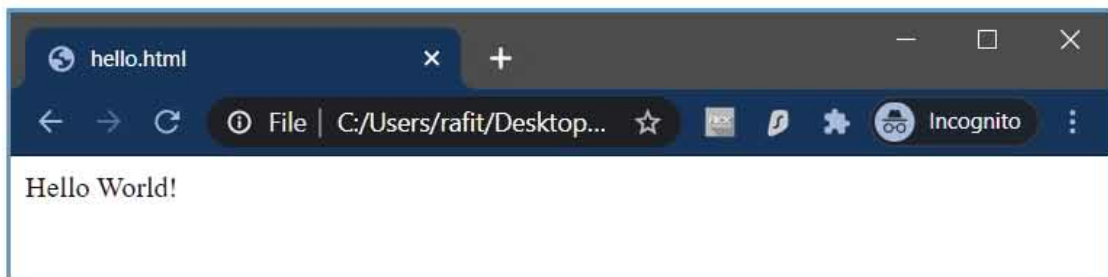

Let's analyse the above code a bit more closely. The first line reads `<!DOCTYPE html>` - this is called the document type declaration. From this a browser knows that this is a html 5 standard document and renders the documents as such. This is not part of the document but it is very important.

All the html elements are contained inside a main element which is html. This is why the second line of the document contains a `<html>` opening tag and the document ends with a `</html>` closing tag. After that we have the `<body>` tag. Everything that is displayed inside the web browser should be inside the body tag. We have written Hello World inside the body tag and our browser displayed that.

If there is a body, there should be a head too. Everything visible from the browser is written inside the body element while the other information such as information about the website, different settings, styles and scripts are written inside the head element. The website title that we see in the browser tab is written inside the head element. Let's add a title to our web page.

```
<!DOCTYPE html>
<html>
<head>
  <title>My first html doc</title>
</head>
<body>
Hello World!
</body>
</html>
```

If we save this code and run it in the browser we can see the Hello World! Text as before and additionally we will notice that the browser title bar is displaying our title. The title of the web page should be written inside <title>...</title> tag inside the head element.



### How to write an element

We can write the elements in an html document sequentially, one after another. We can also write one or more elements inside another element. But one element can not overlap another element. We can compare the elements with differently sized boxes. You can put one or more small sized boxes inside a large box. You can put a box over another or place the boxes side by side. But a box can not reside inside two or more boxes. The boxes' top and bottom can be compared to opening and closing tags.

```
<p><em>Abracadabra</p></em> Wrong
<p><em>Abracadabra</em></p> Right
```



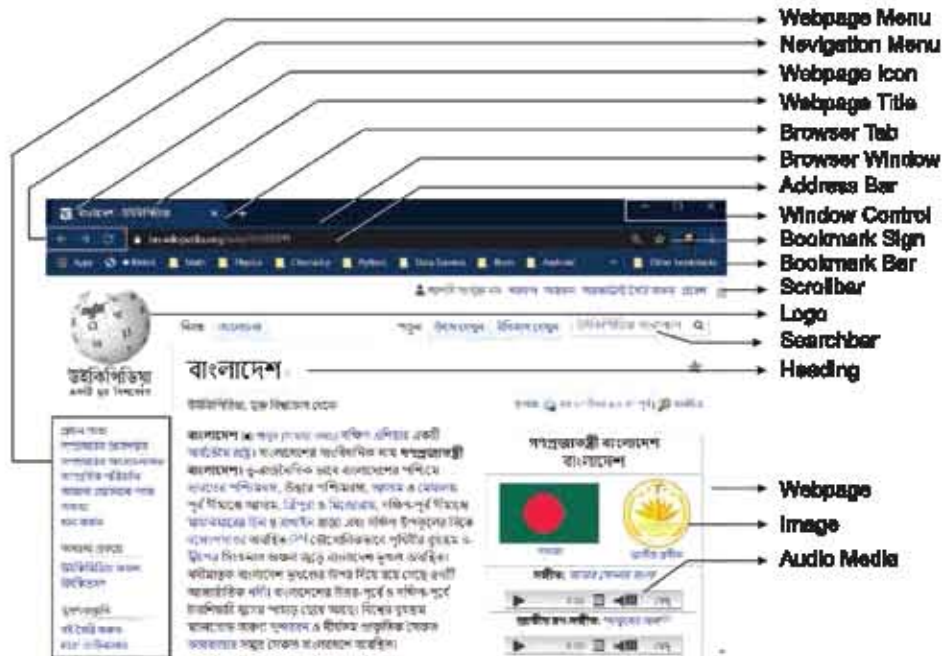

Figure 4.2: Different parts of a Web browser and a Web Page

## Heading

We can see headings of different sizes in newspapers. The main heading is written in the largest font then there are subheadings of different but smaller font sizes. We can do similar things with html headings too. Html has six heading elements. These are expressed as h1, h2, h3, h4, h5 and h6. Here h1 is the largest and h6 is the smallest heading size. To compare the sizes, let's write a code.

```
<!DOCTYPE html>
<html>
  <head>
    <title>HTML Heading</title>
  </head>
  <body>
    <h1>This is heading 1</h1>
    <h2>This is heading 2</h2>
    <h3>This is heading 3</h3>
    <h4>This is heading 4</h4>
    <h5>This is heading 5</h5>
    <h6>This is heading 6</h6>
  </body>
</html>
```

If we run the code in the browser, we will see something like this.

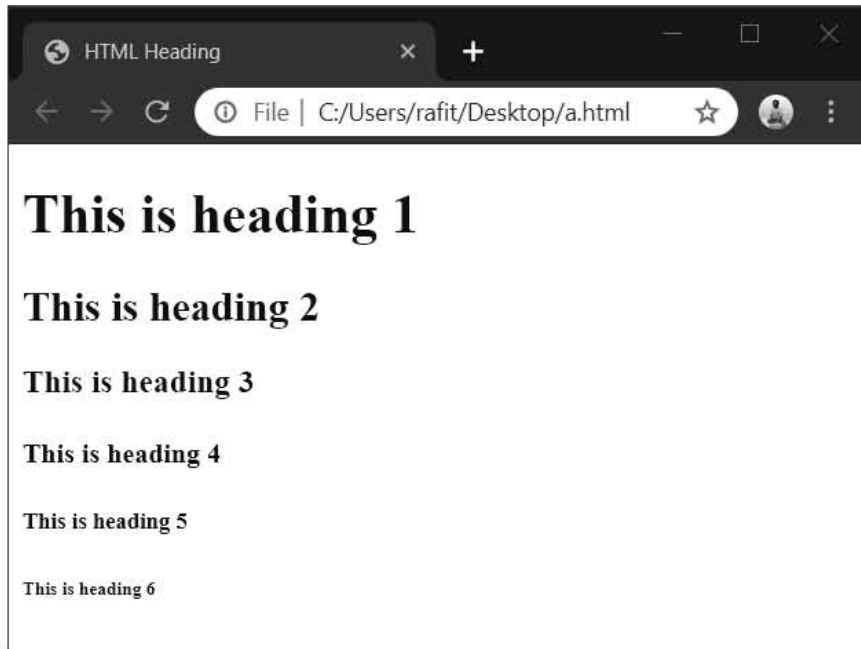

**Figure 4.3:** HTML heading of different sizes

### Some important elements

Let's add some more lines of code to mypage.html.

```
<!DOCTYPE html>
<html>
<head>
  <title>This is my first HTML page</title>
</head>
<body>
Hello World!
This is an html document.
</body>
</html>
```

Save this code in the file and refresh the page in the browser. You can refresh the page by either pressing the reload icon on the browser or hitting the F5 key. We will see that we have written two separate lines inside the body tag but it is showing in the same line in the browser.

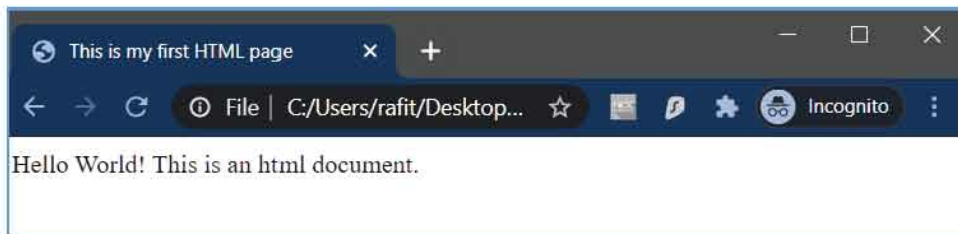

So, how can we display these texts into two separate lines? We have to use a new element `<br>`. This is an empty element so it has no closing tag.

```
<!DOCTYPE html>
<html>
<head>
  <title>This is my first HTML page</title>
</head>
<body>
Hello World! <br>
This is an HTML document.
</body>
</html>
```

Now if we save the code and refresh the page, we will see the texts are in separate lines.

```
<!DOCTYPE html>
<html>
<head>
  <title>This is my first HTML page</title>
</head>
<body>
  Hello World! <br>
  <p>This is an html page. This is paragraph one.</p> <p>This
  is paragraph two.</p>
</body>
</html>
```

If we want to write a paragraph we have to use the `<p>` element. Save the code and refresh the page in the browser and we will get.

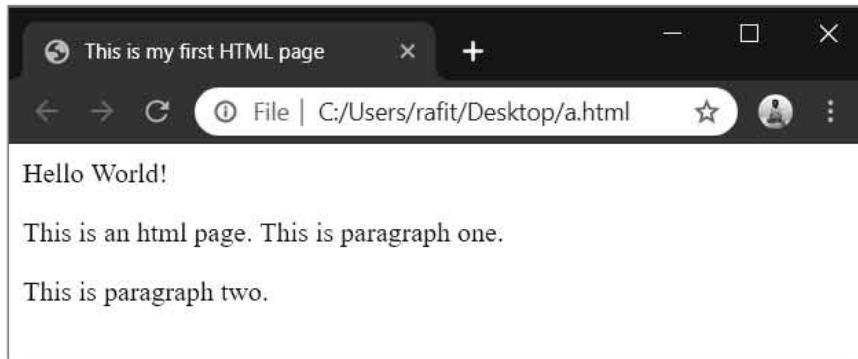

**Figure 4.4: Creating paragraphs**

Here we did not have to explicitly mention a line break or use the `<br>` element. The `p` element itself managed an empty space between lines. But if needed one can use `<br>` element inside a paragraph.

```
<p>This is an html page. This is <br> paragraph one.</p>
<p>This is paragraph two.</p>
```

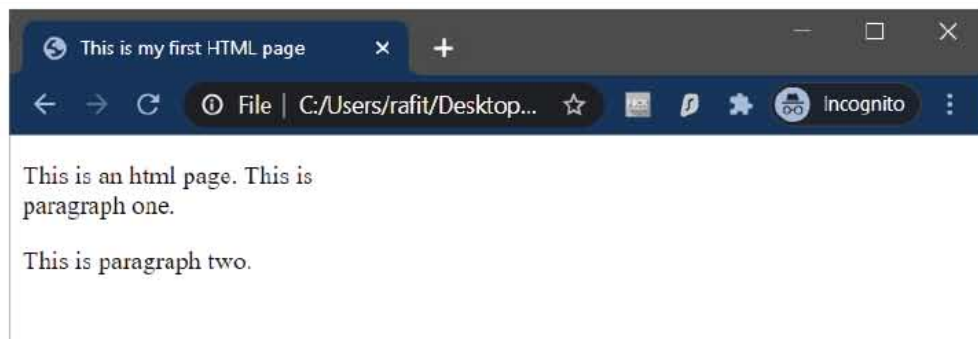

We can see that a paragraph break takes more space than a line break.

If we want to draw a horizontal line, we have to use the `<hr>` element. This is an empty element too.

```
<p>This is an html page. This is paragraph one.</p> <hr>
<p>This is paragraph two.</p>
```

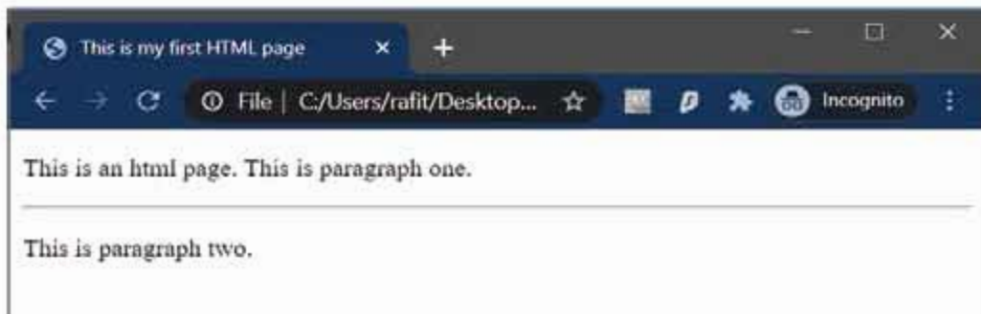

### Text Formatting

The most used text formatting are bold, italics and underlined texts. To use these inside an html we have to use the `<b>`, `<i>` and `<u>` elements.

```
<!DOCTYPE html>
<html>
<head>
  <title>Text Formating</title>
</head>
<body>
  <p>This is normal text</p>
  <p><b>This is bold text</b></p>
  <p><i>This is italic text</i></p>
  <p><u>This is underlined text</u></p>
</body>
</html>
```

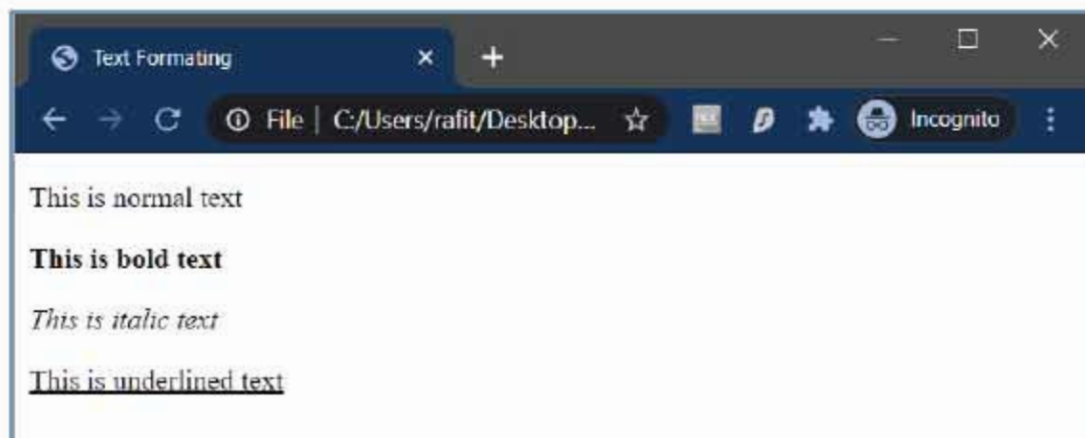

Superscripts and subscripts are among some more commonly used text formatting options. In html documents they are represented by `<sub>` and `<sup>` tags.

```
<p>This line contains a <sup>super</sup>script and a
<sub>sub</sub>script.</p>
<p>(a + b)<sup>2</sup> = a<sup>2</sup> + 2ab +
b<sup>2</sup></p>
<p>f<sub>n</sub> = f<sub>n-1</sub> + f<sub>n-2</sub></p>
```

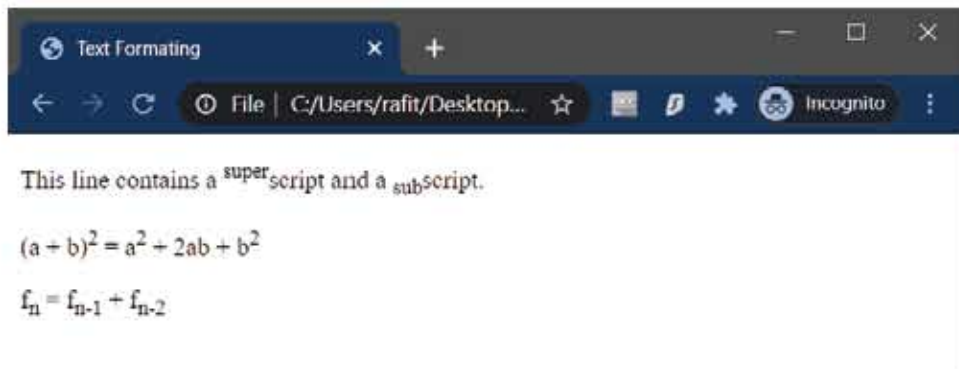

You can use `<big>` and `<small>` elements to make text sizes big and small. Sometimes we need to emphasize a particular text. For this we can use the `<em>` or `<strong>` elements.

```
<p>The word <em>Emphasize</em> means giving special value to
something.
The word <strong>Strong</strong> is something stronger than
emphasizing.</p>
```



## List

To make a list inside an html document we can use the `<ul>`, `<ol>` and `<li>` tags. Let's make a list of the divisions of Bangladesh using these tags.

```
<!DOCTYPE html>
<html>
<head>
  <title>HTML List Demo</title>
</head>
<body>
  <ul>
    <li>Dhaka</li>
    <li>Rajshahi</li>
    <li>Chattogram</li>
    <li>Khulna</li>
    <li>Rangpur</li>
    <li>Barishal</li>
    <li>Sylhet</li>
    <li>Mymensingh</li>
  </ul>
</body>
</html>
```

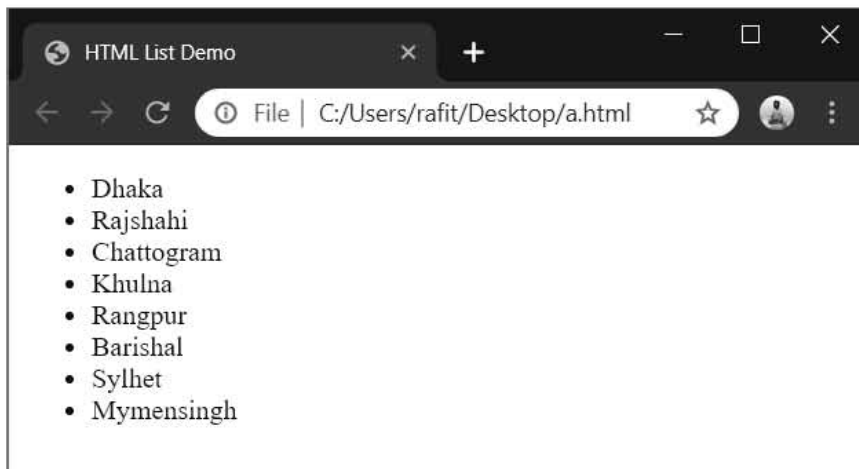
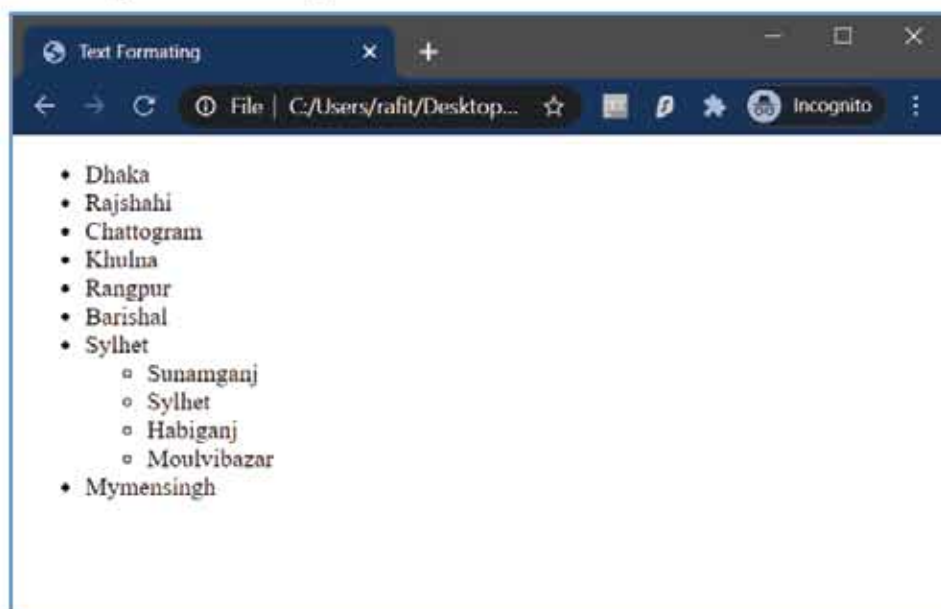

**Figure 4.5:** Showing the divisions of Bangladesh in the list

Here, we used 'ul' and 'li' elements to create a list. Here 'ul' means unordered lists and li signifies the list elements. If we want ordered lists, we have to use the ol tag. You can create nested lists inside 'mhtml' too. To do this, you can simply insert another list inside a list element.

```
<body>
  <ul>
    <li>Dhaka</li>
    <li>Rajshahi</li>
    <li>Chattogram</li>
    <li>Khulna</li>
    <li>Rangpur</li>
    <li>Barishal</li>
    <li>Sylhet</li>
    <ul>
      <li>Sunamganj</li>
      <li>Sylhet</li>
      <li>Habiganj</li>
      <li>Moulvibazar</li>
    </ul>
    <li>Mymensingh</li>
  </ul>
</body>
```

This code will generate an output like this on the browser.



When we create unordered or bulleted lists in HTML, it puts the disc symbol by default in front of each element. We can use the circle or the square symbol if we want. For this, we have to use attribute inside of an element. Attributes are part of an HTML element that modifies the functionality of that element. An element can have multiple attributes or no attributes at all.



The convention of writing attributes are as follows -

```
<tag attribute_name="value">
```

So we have to write the attribute name inside a tag and follow the value of that attribute with an equal sign. To use circle or square symbols for bulleted lists, we have to use the type attribute.

```
<ul type="square">
  <li>item 1</li>
  <li>item 2</li>
</ul>
```

This code will put the square symbol in unordered lists. Likewise we can write `<ul type='circle'>` to get the circle symbol.

HTML Code	Output
<pre>&lt;ul type="square"&gt;   &lt;li&gt;Item 1&lt;/li&gt;   &lt;li&gt;Item 2&lt;/li&gt; &lt;/ul&gt;</pre>	<ul style="list-style-type: none"> <li>▪ Item 1</li> <li>▪ Item 2</li> </ul>
<pre>&lt;ul type="circle"&gt;   &lt;li&gt;Item 1&lt;/li&gt;   &lt;li&gt;Item 2&lt;/li&gt; &lt;/ul&gt;</pre>	<ul style="list-style-type: none"> <li>○ Item 1</li> <li>○ Item 2</li> </ul>
<pre>&lt;ul type="disk"&gt;   &lt;li&gt;Item 1&lt;/li&gt;   &lt;li&gt;Item 2&lt;/li&gt; &lt;/ul&gt;</pre>	<ul style="list-style-type: none"> <li>● Item 1</li> <li>● Item 2</li> </ul>

We can use attributes to modify ordered lists too. For example we can use Roman numerals or English alphabets to denote the list item numbers. Type attribute is used here also.

HTML Code	Output
<pre>&lt;ol type="i"&gt;   &lt;li&gt;Item 1&lt;/li&gt;   &lt;li&gt;Item 2&lt;/li&gt; &lt;/ol&gt;</pre>	i. Item 1 ii. Item 2
<pre>&lt;ol type="I"&gt;   &lt;li&gt;Item 1&lt;/li&gt;   &lt;li&gt;Item 2&lt;/li&gt; &lt;/ol&gt;</pre>	I. Item 1 II. Item 2
<pre>&lt;ol type="a"&gt;   &lt;li&gt;Item 1&lt;/li&gt;   &lt;li&gt;Item 2&lt;/li&gt; &lt;/ol&gt;</pre>	a. Item 1 b. Item 2
<pre>&lt;ol type="A"&gt;   &lt;li&gt;Item 1&lt;/li&gt;   &lt;li&gt;Item 2&lt;/li&gt; &lt;/ol&gt;</pre>	A. Item 1 B. Item 2
<pre>&lt;ol type="1"&gt;   &lt;li&gt;Item 1&lt;/li&gt;   &lt;li&gt;Item 2&lt;/li&gt; &lt;/ol&gt;</pre>	1. Item 1 2. Item 2

We can start an ordered list from a particular number too. Lets say we want to display a list of students from roll 21 to 30. In this case we have to use the start attribute. Whatever the type is, the value of the start attribute should always be numeric.

```
<ol type="1" start="21">
  <li>Nayeem Sheikh</li>
  <li>Robiul Hasan</li>
  ... ..
</ol>
```

## Hyperlink

We can see various different links in websites while browsing. Clicking a link takes us to another web page or a different section of the same web page. Link creates a connection between a page to another page or with different sections of the same page. Links on html are called hyperlinks.

In the list of division we created earlier, let's put hyperlinks on that page so when we click Dhaka we are taken to the website of Dhaka division. For this, we have to use the anchor element which is represented by the `<a>` tag.

```
<li><a href="http://www.dhakadiv.gov.bd/">Dhaka</a></li>
```

After refreshing the page in the browser we will see that the text Dhaka is now in blue and underlined. By clicking on that we will be taken to Dhaka division website. The web address or 'url' is set by the href attribute.

**Do it yourself:** Complete the code so that clicking any division's name will take the user to that division's website.

If we want we can make the link open in a new tab in the browser instead of opening the link in the same tab. For this we have to use the target attribute. If we use `_self` as a value in the target attribute, the link will open in the same tab and if we use `_blank` as a value then the link will open in a new tab.

```
<li><a href="http://www.dhakadiv.gov.bd/"
target="_blank">Dhaka</a></li>
```

## Image

If we want to add images to our web page we have to use the `img` element. This is an empty element so it has no closing tag.

```
<!DOCTYPE html>
<html>
<head>
  <title>Image in html</title>
</head>
<body>
  
</body>
</html>
```

Get an image file, rename it to `image.jpg` and put it into the same folder as the code. Now if we open the file in the browser, we can see the image on the web page.

We used the source or the 'src' attribute to define the location of the image. This location can be a web address too. If the image is in another folder, the value will be the path of the file. If the image file is in My Pictures folder in D drive, the code will be -

```

```

If the image is too big in size then the browser may display parts of the image. To view the image properly, we can control the size of the display. For this we have width and height attributes. If we want to see the image in 300x200 pixel we have to write -

```

```

Sometimes clicking an image in a website takes us to another page. This means that image was a hyperlink.

```
<a href="https://www.google.com" target="_blank">  
    
</a>
```

So we can use images inside the anchor element instead of texts.

## Tables

We can create tables using html codes. Tables have rows and columns and cells. The topmost row in a table is known as the header row and the bottom row of the table is known as footer row. Header and footer rows in a table are optional elements, not all tables have them.

```
<!DOCTYPE html>  
<html>  
<head>  
  <title>HTML Table Example</title>  
</head>  
<body>  
  <table>  
    <thead>  
      <tr> <th>Serial</th> <th>Subject</th> <th>GPA</th>  
</tr>  
    </thead>  
    <tbody>  
      <tr> <td>01</td> <td>Bangla</td> <td>5.00</td> </tr>  
      <tr> <td>02</td> <td>English</td> <td>5.00</td> </tr>  
      <tr> <td>03</td> <td>Science</td> <td>5.00</td> </tr>  
      <tr> <td>04</td> <td>Math</td> <td>5.00</td> </tr>  
    </tbody>  
    <tfoot>  
      <tr> <td></td> <td>CGPA</td> <td>5.00</td> </tr>  
    </tfoot>  
  </table>  
</body>  
</html>
```

This code will produce an output like the following -

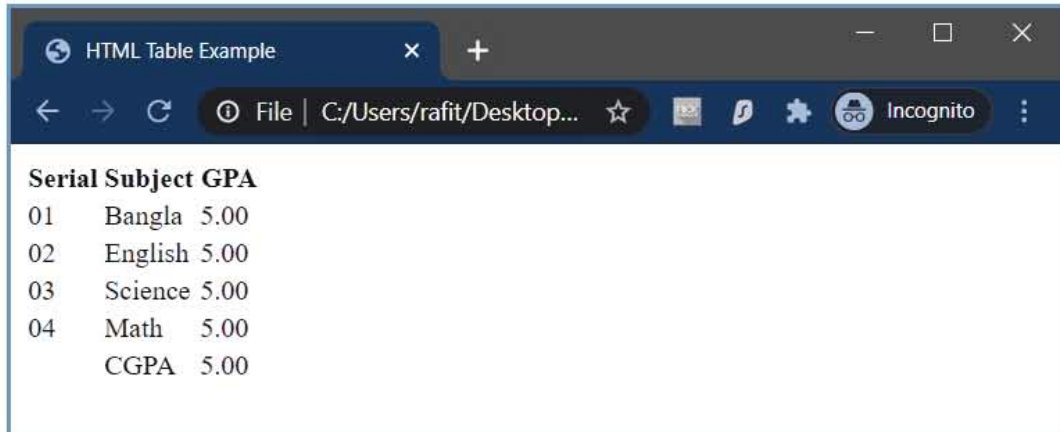

To create a table in an html document, we need the table element. Each table element can have three different elements inside them - header, body and footer. These are represented as `thead`, `tbody` and `tfoot` elements. To create rows in a table, we have the `tr` or the table row element. If we want ten rows in a table, we have to have ten `tr` elements. Table headings are put with the `th` element. Using the `th` element makes the headings bold.

We create table rows with `tr` elements and to put data inside the cells, we have to use the `td` or table data element.

By default html tables will not have any borders. To create a border we need to use the `border` attribute inside the table element.

```
<table border="1">
```

If we use a border attribute like this we will see a double lined border around each cell.

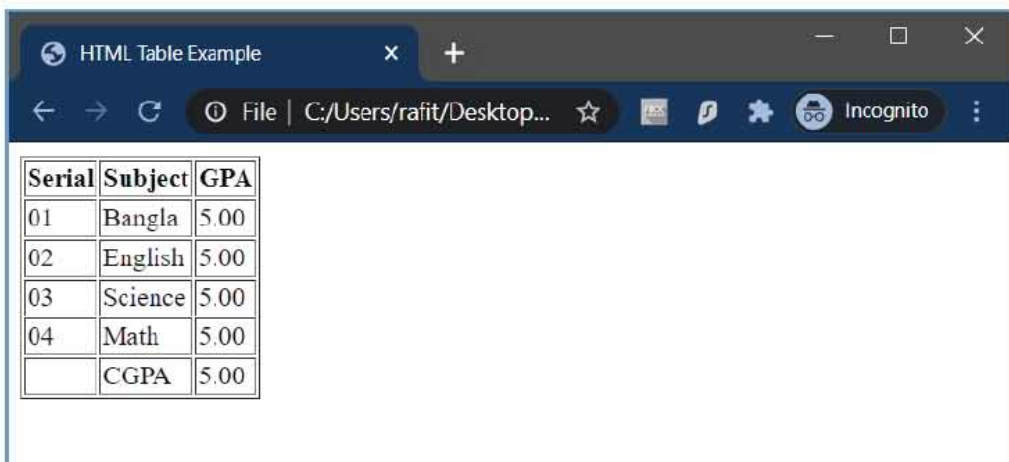

To get rid of this we have to use the cellspacing attribute inside the table element. This attribute controls how much space the cells are allowed. The value of the cellspacing attribute determines how much space will be between two adjacent cells.

```
<table border="1" cellspacing="0">
```

The text inside a cell is at a certain distance from the cell borders. You can control this using the cellpadding attribute.

```
<table border="1" cellpadding="20">
```

Using this knowledge our table can look good like the following.

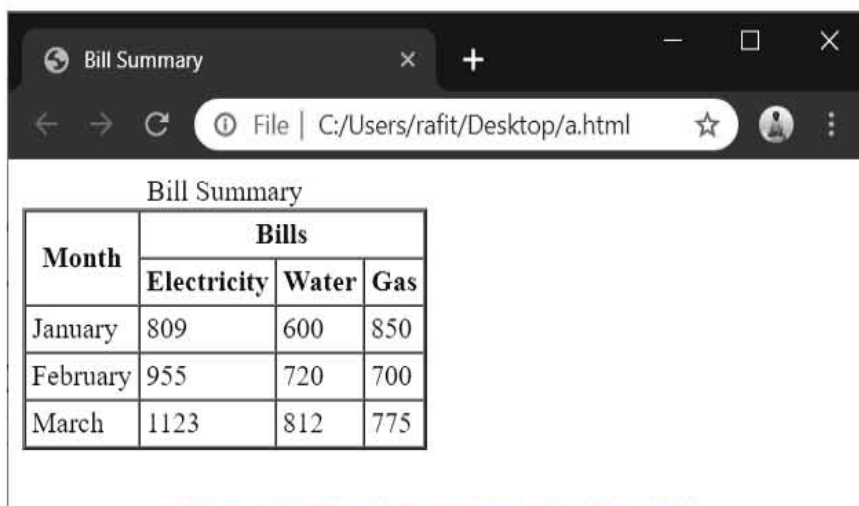

The screenshot shows a web browser window titled "Bill Summary" with the address bar displaying "File | C:/Users/rafit/Desktop/a.html". The main content area contains a table with the following structure:

Bill Summary			
Month	Bills		
	Electricity	Water	Gas
January	809	600	850
February	955	720	700
March	1123	812	775

Figure 4.6: How to create a table like this?

**Things to notice in the above image is:**

- The table has a caption
- The month cell is comprised of two rows
- The bill's cell is comprised of three columns
- All the other cells are as it is

The caption element is used to put a caption for the table. If we want to make a cell expand to several rows, we have to use the rowspan attribute. Similarly to make a cell consisting of several columns we need to use the colspan attribute. The following code will explain it better.

```

<!DOCTYPE html>
<html>
<head>
  <title>HTML Table Example</title>
</head>
<body>
  <table border="1" cellspacing="0" cellpadding="2">
    <caption>Bill Summery</caption>
    <thead>
      <!--
        The first th element will span two rows. Second th
        Element will span three columns.
      -->
      <tr>
        <th rowspan="2">Month</th><th colspan="3">Bills</th>
      </tr>

<tr><th>Electricity</th><th>Water</th><th>Gas</th></tr>
      <!--
        On the second row, the first th element will go to
        Second column. Because second row of first column is
        spanned by first row.
      -->
    </thead>
    <tbody>
      <tr>
        <td>January</td><td>513</td><td>53</td><td>217</td>
      </tr>
      <tr>
        <td>February</td><td>522</td><td>59</td><td>202</td>
      </tr>
      <tr>
        <td>March</td><td>578</td><td>62</td><td>224</td>
      </tr>
    </tbody>
  </table>
</body>
</html>

```

You will notice that in the above code there are some texts between `<!--` and `-->` tags. The texts explain what is inside the `thead` element. This is called a comment. When the code is rendered through the browser, the comment part will not be displayed. Comments are put in by the developers so that they can understand the code better. Comments improve the readability of a code for other developers.

You can put hyperlinks inside a table cell using the `a` element. You can also put an image into a table cell. It's important that you control the display size of an image while putting it inside a table cell, otherwise the table might seem broken.

```
<td><a href="https://www.google.com">Google</a></td>
```

## Display Bangla inside a Web Page

The following code demonstrates how to put bangla texts inside a web page.

```
<!DOCTYPE html>
<html>
<head>
  <title>Bangla Text in Webpage</title>
</head>
<body>
  <p>A markup language in HTML. It is very easy to learn.</p>
</body>
</html>
```

Not all computers can render the Bangla texts directly though. To properly display Bangla texts, we have to use an empty element called `meta` and an attribute named `charset`. The `meta` element will be inside the `head` element, it defines the settings of the page.

```
<!DOCTYPE html>
<html lang="bn">
<head>
  <title>Bangla Text in Webpage</title>
  <meta charset="utf-8">
</head>
<body>
  <p>A markup language in HTML. It is very easy to learn. </p>
</body>
</html>
```

The `charset="utf8"` means to display the texts the browser needs UTF-6 character sets. UTF-8 is a popular unicode character set that supports Bangla.

As you can see we have added a new attribute `lang` inside the code. The `lang` attribute notifies the browser the language of the texts in the web document. If a language has multiple dialects, we have to use the region code too. For example, for American English we need to use `en-US` and for British English, we need to use `en-UK`.



## Div and Span Element

A web document can have different parts and sections, their functionality, structure and look can be different too. To distinguish these different parts, div elements are used.

The span element selects a particular part of an element. Let's say we have a paragraph written in black text but we want three words inside the paragraph to be displayed in red color. So we put those three words inside the span element and use the style attribute to change the color.

```
<p>This is a black text. But <span style="color:red;">This  
is red</span></p>
```

## Style attribute

With the style attribute we can define an elements color, fonts and many different properties. Style attributes are used for styling an element as we have demonstrated in our previous example where we used red color. Different elements have different properties so if we want to define the values we have to use semicolon between each property.

```
<!DOCTYPE html>  
<html>  
<head>  
  <title>Style Attribute Experiment</title>  
</head>  
<body>  
  
  <div style="width:100px; height:100px; background-color:  
pink; color: darkred; float: left; margin: 5px; padding:  
5px;">Hello There!</div>  
  
  <div style="width:100px; height:100px; background-color:  
paleturquoise; color: forestgreen; float: left; margin: 5px;  
padding: 5px;">How are you!</div>  
  
  <div style="width:100px; height:100px; background-color:  
lightskyblue; color: royalblue; float: left; margin: 5px;  
padding: 5px;">Nice to meet you!</div>  
  
</body>  
</html>
```

This code will have an output like the following.

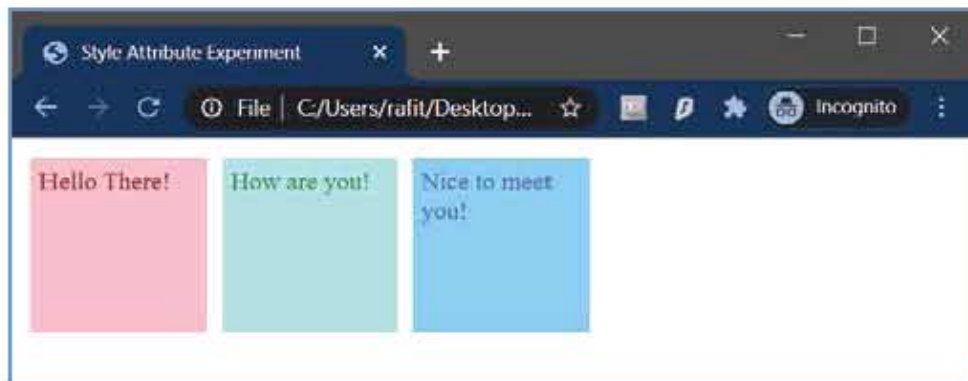

If we want to use the same style in different elements, we can define them inside the head element with style tags. The following example explains it better.

```
<!DOCTYPE html>
<html>
<head>
  <title>Style Attribute Experiment</title>
  <style type="text/css">
    div {
      width:100px;
      height:100px;
      float: left;
      margin: 10px;
      padding: 10px;
      font-family: sans-serif;
      font-size: large;
      border: 2px solid rgba(0, 0, 0, 0.2);
      border-radius: 5px;
      text-align: center;
    }
  </style>
</head>
<body>
  <div style="background-color: pink; color: darkred;">Hello
  There!</div>
  <div style="background-color: paleturquoise; color:
  forestgreen;">How are you!</div>
  <div style="background-color: lightskyblue; color:
  royalblue;">Nice to meet you!</div>
</body>
</html>
```

In the style tag we have defined the style for all div elements. And we have defined the background color property inside each div element too. We can use the style attribute to beautify our web page in many different ways.



Some properties and their use are described below:

Property name	Use
width	Defines the width of an element
height	Defines the height of an element
font-family	Defines font
font-size	Defines font size
margin	Defines the distance with other elements
padding	Defines the distance of the element from the border
border	Defines the border
text-align	Defines text alignment, values can be left, right, center
colour	Defines element colour
background-colour	Defines background colour

### 4.3 Designing Web Page

---

To get a good looking website, first you need a good looking design. A couple of things should be kept in mind while designing a website. The first and foremost of them is making the website easy to use for the users, are they finding the right things, does it look good to them?

Designing a website depends on what type of website are you making. Lets say we are designing a website where a user can ask programming related questions and answer programming related questions. First, we have to decide upon what features the website will have. The features can be of the following:

- Users can register and log in to the website
- Users can post questions
- Users can post an answer to an already posted question
- The user who asked the questions can choose the best answer
- If a user likes an answer he or she can upvote them
- Users can earn points for asking good questions or providing good answers

Now let's find out what pages will be in the website. We have to design a layout for every page. In the layout, we will define which elements will be positioned where in that page. Primarily, we will make the design in pen and paper. This type of basic design is called a wireframe. The wireframe of the answers page can be seen in the picture. We can also used graphics design softwares like Adobe Illustrator or Gimp to create such designs.

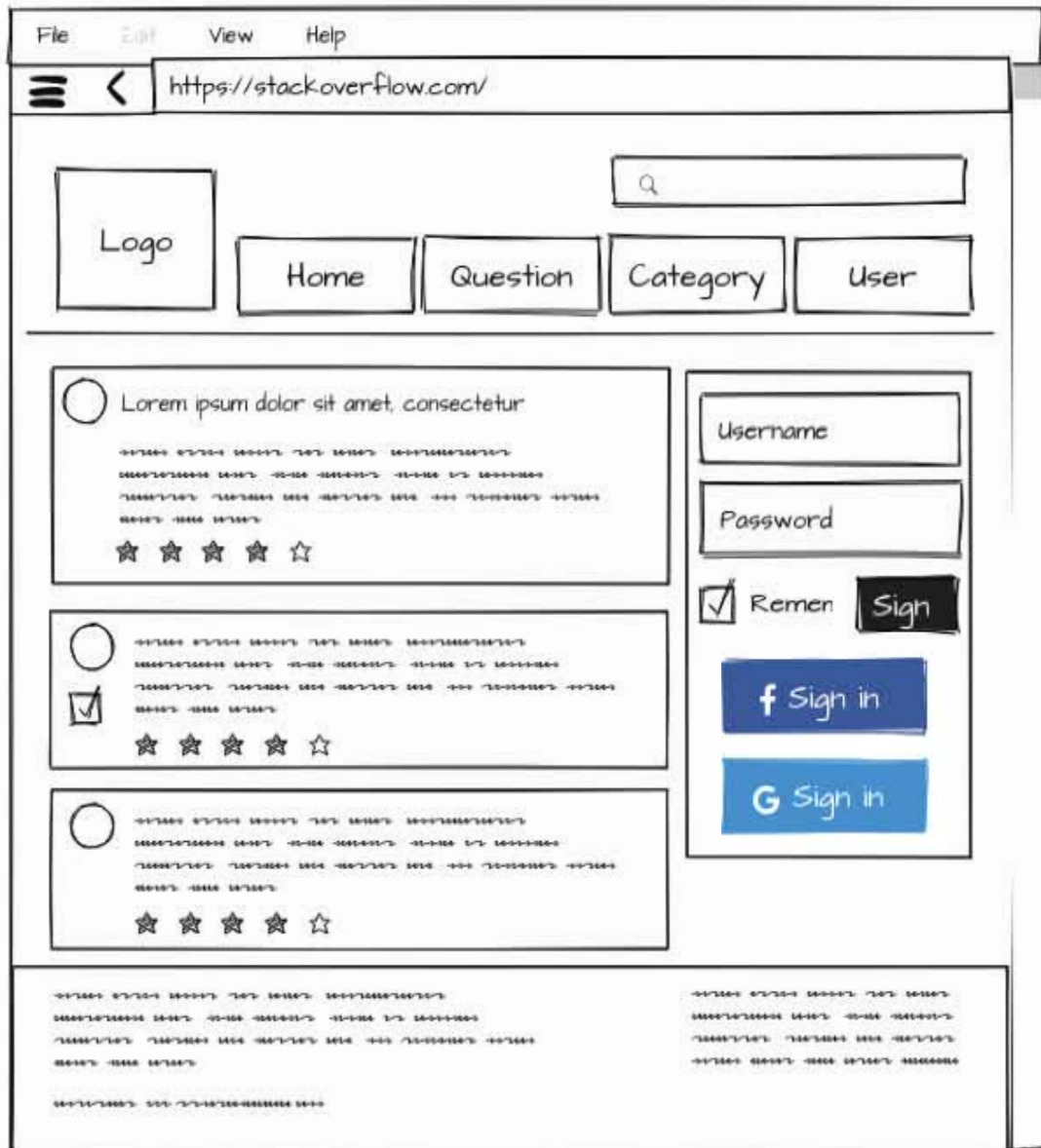

**Figure 4.7:** A design of a Q&A based website

After the design phase we got to start the development. HTML and CSS files are to be used to create the required pages according to the design. This is known as the front-end development of the website. In reality, you are going to need the knowledge of many more programming languages, softwares and libraries besides HTML and CSS. This book will not go that far for now.

Some programming is also needed for feature implementations and connecting the website to a database server. This part is known as the back-end development. The developers who are capable of both front and back end developments are known as full-stack developers.

During development needs and requirements might compel you to change the web design one or more times. You have to write the codes keeping this in mind that you might have to change some parts. During and after the development, testing and debugging must be performed to ensure that all the intended features are working correctly and running without any bug.

#### 4.4 Publishing a Website

---

A website needs to be published so all users of the internet have access to it. In short the website needs to be served from a computer that is alive all the time and is connected to the internet. To find your website you will need a public IP address. Public IP address is the address of your website or your computer for the internet. Our personal computers that come with internet connections usually do not have a public IP address. You can get a public IP address by contacting your internet service provider. But it is hard to keep your computer open 24/7. For this reason there are many organizations in the world who provide hosting services so you can host and publish your website on the internet. Uploading the website files to a web server in order to publish the website to the internet is called hosting.

You can use IP addresses to browse any website, but in real life people do not usually use IP addresses to browse because it is not easy to remember those addresses. So your websites must have a domain name. Bangladesh.gov.bd or wikipedia.org are domain names. You can buy your preferred domain name only if it is not already purchased by someone else. After you get the domain name you have to connect that to your hosting server address. Then anyone on the internet can type your domain name on their browser and access your website.

## Exercise

### MCQ

- What tag is used to link between web pages?
  - `<a>`
  - `<href>`
  - `<i>`
  - `<div>`
- Using hyperlinks in a webpages makes -
  - an informative page
  - it labor intensive
  - it attractive
 Which one is true?
  - i and ii
  - i and iii
  - ii and iii
  - i, ii and iii
- In which case we use domain names?
  - Websites
  - Servers
  - Web files
  - Folders
- ```

<html>
<body>
<p> <b> First Paragraph</b></p>
<a href = "test.html"> Test Website</a>
</body>
</html>

```

 What type of tags are used here?
  - Formatting
  - Hyperlink
  - Image
 Which one is true?
  - i and ii
  - i and iii
  - ii and iii
  - i, ii and iii
- What will you see from the following code: `<p>H<sup>2</sup>O</p>`
  - H<sub>2</sub>O
  - H<sub>2</sub>O
  - H<sub>2</sub>O
  - HO
- To add map.jpeg image of 640x480 pixels inside a webpage what type of directives do you need?
  - `width='640' height='480'`
  - `Pixlw="640" pixel="480"`
  - `w="640" h="480"`
  - `PixWid="640" PixHigh="480"`
- Sarika added a new image on her newly created web page. This made it more attractive. What tag did she use?
  - `<img>`
  - `<fig>`
  - `<photo>`
  - `<illus>`
- What attribute is used to open a web page in a new window?
  - Href
  - Target
  - Src
  - Title





d. Why was the website not accessible after a while? What could be the problem? Explain.

3. ABC College, Dhaka

Available subjects: Bangla, English, Mathematics, Accounting.

a. What is a web page?

b. Describe the importance of domain names.

c. Write an HTML code for ABC College.

d. Write an HTML code that displays the subject table in a tabular form with serial No. and Subject name as column headers.

4. See the following code and answer the questions

```
<html>
<head> <title> ICT </title> </head>
<body>
<h3> COLLEGE RESULT </h3>
<table>
<tr>
<th> Roll </th> <th> Name </th> <th> Result </th>
</tr>
<tr>
<td> 501 <td> Sumaiya <td>
<td> <a href = "Exam Result.html"> My Test Result </a> </td>
</tr>
</table>
</body>
</html>
```

a. What is a web browser?

b. Why is using domain names easier than using IP addresses? Explain.

c. Explain the code structure.

d. What is your opinion on the code given above?

5.

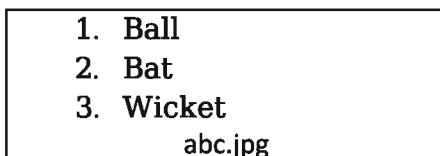

Figure-1

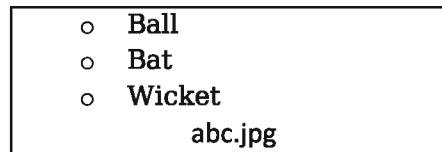

Figure-2

a. Why is HTML an easy way to build a web page?

b. Write a code to build a web page according to figure 1.

c. What code will you need to change to get the result in figure 2?

d. We can present figure 1 as like figure 2- Analyze.

## Chapter Five

### Programming Language

---



Students participating in a programming contest

Computers have touched the lives of every human in some way or the other over the past few decades. The potentials of what can be done with this machine are limitless. What is the difference of computer and any other machine? Well, the main advantage of a computer is, it can be programmed in a certain way to do certain tasks. But a computer is only an electronic machine after all, it can not understand human language. We can only make it understand binary, 0 and 1. To program a computer, we must provide instructions in machine code, with 0s and 1s. Writing machine code is not at all easy for a human being, so we have developed many programming languages. You can write codes in one of these languages then your code is converted to machine codes and sent to the computer for execution. C is such a programming language. C is very popular and widely used as a programming language. In this chapter students will learn the basics of programming and with that the basics of C language too.

**After completing this chapter students can**

- Explain the concepts of programming
- Describe different levels of programming languages practical
- Demonstrate programming structure
- Make algorithms and flowcharts
- Use C language to write codes.

## 5.1 Concept of Programming

---

Every computer has a central processing unit or a CPU. A present day microprocessor has on or more CPUs embedded. CPU does calculations and data processing.

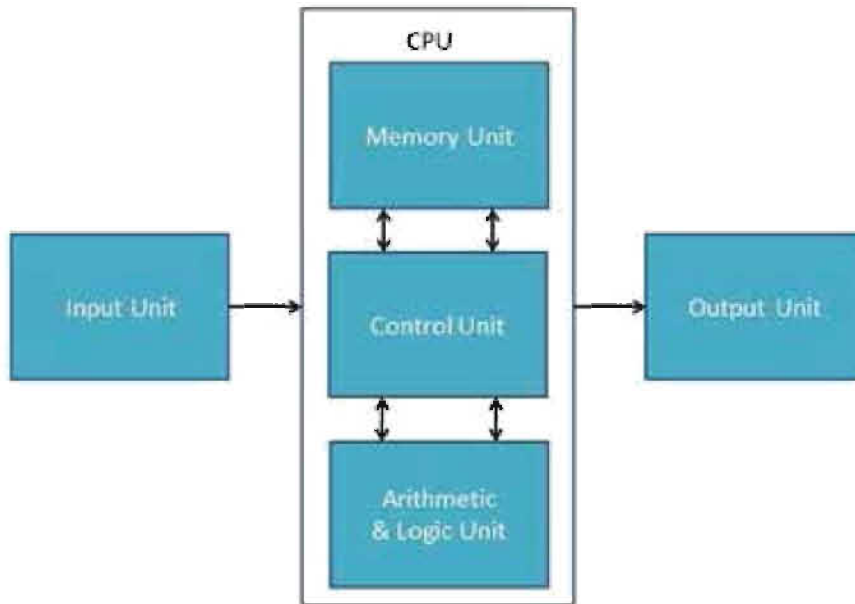

**Figure 5.1:** A block diagram of a computer

A microprocessor can perform addition, subtraction, multiplication division and many more operations. These operations are performed on data that are stored in computer memory. The outputs are stored into computer memory too.

Computer memory is of two types - volatile and non-volatile. Non volatile memory can store and retrieve data even after the computer is shut down and restarted. Hard disks, USB drives, DVDs are examples of non-volatile memory. Volatile memories are erased when the computer or a particular program is shut down. RAM is a volatile memory. When a computer program is processing data, they usually use the volatile memory as it is a lot faster than non-volatile memory.

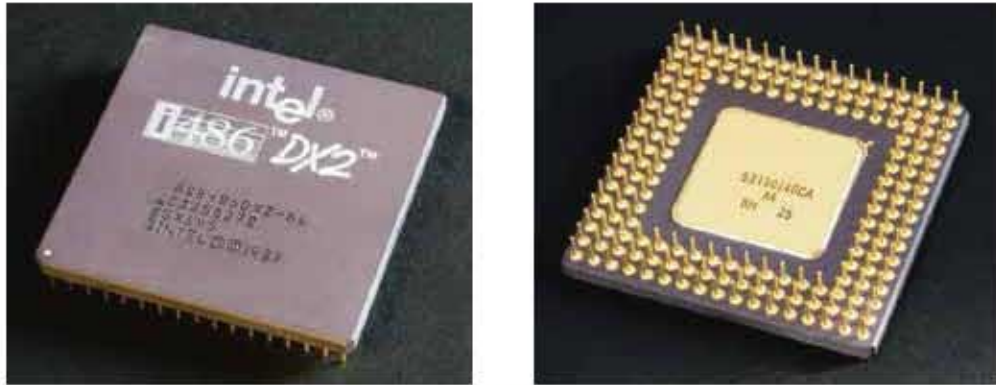

Figure 5.2: Front and back view of a microprocessor

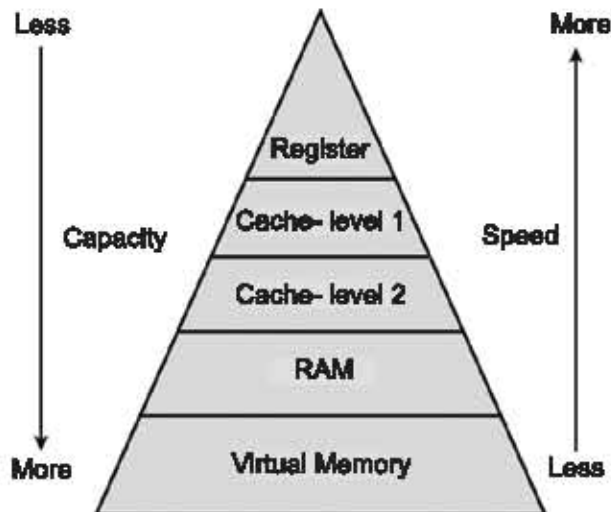

Figure 5.3: Different states of computer memory

The computer processor holds some memory too. The closest to the processor there are registers and then the cache memory. Cache memory has larger capacity than the register but comparatively slower than the register. Register and cache are integrated with the processor. Then there is RAM. RAM is connected with the processor through the motherboard. RAM has larger storage capacity than cache but is slower.

Register memory is the most expensive then cache memory. RAM is cheaper in comparison with these two. After the RAM we get the virtual memory. When the RAM is full a portion of the hard disk is allocated as virtual memory by the computer operating system. This is however very slow compared to the RAM.

## 5.2 Programming Language

If you want to get the computer do a particular task, you have to provide a special set of instructions. A computer processor can only execute a particular set of commands which are known as the instruction set. But real life programmers do not usually use the instruction sets. To make life easier for them, over time we have created countless programming languages to translate our instructions to the computer.

Some popular programming languages invented over the past decades

Programming language	Year of Invention
Fortran	1954-57
Lisp	1956-59
Cobol	1959-60
Basic	1964
Pascal	1970
C	1972
C++	1983
Perl	1987
Python	1989

Programming language	Year of Invention
Visual Basic	1991
PHP	1995
Java	1995
Javascript	1995
Scala	2003
Go	2009
Rust	2010
Kotlin	2011

### 5.2.1 Machine Language

We already know that a computer processor can only recognize binary numbers. Binary numbers contain only two digits - 0 and 1. So to get a machine to understand and execute our instructions, we have to provide a code with only 0 and 1 in it. This is known as the machine code and the language is known as machine language. Although machine codes are easily understood by the machine, its nearly illegible for a human being. As the codes contain only 0s and 1s, writing a program in machine language is a really arduous task to say the least.



Figure 5.4: First programmer Ada Lovelace(1815-1852)

The processor manufacturers usually provide an instruction set with their processor so that programmers may use them. This set contains some simple instructions that can be used to write programs and which is a lot easier than writing programs in machine language.

### 5.2.2 Assembly Language

Assembly language was invented after the machine language so the programmers can write programs with relative ease. This is a programming language that has English words and instructions in it alongside numbers. So it is more comfortable to use and learn for a programmer. A computer processor can not however run a program written in assembly, it has to convert the code to machine language first. A program named 'Assembler' is used to convert an Assembly Code to Machine Code.

### 5.2.3 Mid-Level Language

Mid level languages stand between Assembly and high level languages. Mid level languages are really handy to use when you require a direct interaction between hardware and your programming. C is a great example of a mid level language. With C you can write system programs like operating systems and you can also write software applications for everyday use.

### 5.2.4 High Level Language

Machine language and Assembly Language are known as low level languages. Though Assembly made it easier for programmers to understand the code, it takes a lot of time and effort to write a program in Assembly or even understand a program written by someone else. So people felt the need for a more legible and easy to use language. Mid and High level languages were created to meet this demand. Mid level languages like Fortran, Cobol and C revolutionized the field of programming. They were easy to learn and easy to use, so more people got involved in computer programming. With time we created high level languages like C++, Java, C#, Python and many more. These high level languages are so easy to use and understand that a code written in any of these languages is close to English language itself.

## C

C is a very popular programming language which was invented by Dennis Ritchie in Bell Communications Laboratory in 1972. There is a saying that, if you know C, you can learn any programming language. C can be used to create complex software systems like the operating system, database management systems, internet browsers and many more. C is a structured programming language that can be used to create massive and complex programs.

**C++**

Class is a very important concept in the field of programming. Objects of similar attributes are defined by a class. Adding Classes and some new and exciting features with the C language Bjarne Stroustrup created the C++ language in 1980 working at Bell Laboratory. The main theme of C++ is to give the programmer a lot of freedom in writing their codes.

**Visual Basic**

Microsoft created the Visual Basic Language in 1991 so people can write programs for their Windows operating systems. Visual Basic became very popular very fast because it was really easy to learn and it let the programmers run their changed code without compiling again.

**Java**

Sun Microsystems developed the Java language in 1991. The main feature of Java is it follows the WORA principle, which means Write Once, Run Anywhere. Basically you can compile a Java code in one platform and run the code in any platform. This feature made the web applets developed in Java very popular in popular internet browsers.

**Algol**

The combined effort of many computer scientists from Europe and the USA gave birth to the programming language Algol or Algorithmic Language in 1958. It was a really modern programming language and was ahead of its time. Many modern programming languages of present bear resemblance to Algol even now. Algol was primarily used in the field of research and science, but it never became too popular in the outside world.

**Fortran**

IMB created a high level programming language called FORTRAN or Formula Translation in 1957 to be used in the field of science and technology. It was very popular among scientists and researchers as it made mathematical analysis really easy. In the past, FORTRAN was the sole programming language used by the scientist community. FORTRAN is still used to this day in huge simulations as it can run calculations at a much higher speed than any other language except for C. FORTRAN's last update was released in 2018. FORTRAN is still used by researchers in the fields of physics and chemistry because many previous problems solutions were simulated and compiled in FORTRAN.

## Python

Python was invented by Guido Van Rossum in 1991. Python is one of the most popular programming languages of the present and in 2018 IEEE recognized Python as the greatest programming language. Python's best feature is its readable syntax and easy to use structure. Python codes can run in multiple platforms and are generally used in developing cloud based web applications, data analytics and machine learning applications.

### 5.2.5 4th Generation Language

The goal of 4th generation programming languages are to make programming easier for general people and so that the codes resemble human languages. The SQL language we are going to learn in the Database chapter is a 4GL language. The graphical user interfaces we use in different tools and softwares are the direct result of 4GL.

## 5.3 Translator Program

---

At present there are thousands of programming languages being used by millions of programmers. Though most of these languages are different in structure and syntax, all of them must be compiled into machine codes so that computers can execute the sets of instructions. A translator program does exactly that. We will learn about three types of translator programs.

### Assembler

Assembler converts a code written in Assembly language to a machine code. High level languages use two different types of translator programs to convert their codes to machine codes. These are compilers and interpreters. Every high level language has different sets of compilers and interpreters.

### Compiler

A compiler program scans through a code to detect if the code is written following all the standards and syntax of that particular programming language. If everything is okay and no error is found, the compiler converts the code into machine code. As the whole program is compiled together so all the errors are shown together too. This makes correcting errors a bit difficult and tedious. But once compiled, the programs can run really fast.



## Interpreter

An interpreter does not run through the whole program at once but check each statement individually and convert each statement into machine code. If a program has 10 statements, an interpreter will first convert the first statement to machine code and execute it, then the second, then the third and so on. This makes finding and correcting errors in the coding really easy. But the interpreter program takes a lot of time to finish executing.

## 5.4 Program Structure

---

A program can have different smaller parts, the whole program structure, structure of the small parts and their relation is called a Program Structure. Some program structures are good and then there are some bad program structures. A good program structure maintains all the common conventions, the internal parts are readable, transparent and easy to understand. A good structure uses proper data structure where it is meant to be used and maintains a definite flow control of the program. Whereas in a bad programming structure the conventions are not followed, the relation between parts are illegible and unnecessarily complex. The flow control of the program is haphazardly maintained.

### Steps of Developing a Program

A programmer does not just think of a program and start to write codes. Firstly, he has to think about the problem and how can it be solved with his program, how it will be done. Every step to solving the problem is written down first. These steps are known as the algorithm. It is easier to explain with a figure rather than just texts though. The problem solving technique expressed with a figure is known as a flow chart.

### 5.5.1 Algorithm

Picture a student who rides a bicycle every morning to get to his college. If the bicycle is not in a running condition however, he goes to college by rickshaw. So, we can write his steps of going to college like this:

1. Is the bicycle in running condition? If the answer is yes, go to step 4. If the answer is no, go to the next step.
2. Collect rickshaw fare from parents
3. Get on a rickshaw and start for college. Go to step 5
4. Get on the bicycle and start for college
5. You have reached college

The above steps can be called as the algorithm for that student's going to college. There are no specific rules or conventions for writing algorithms. You have to make sure that the steps are written in order and the steps are executed in order, then you can reach the solution to your problem. After a step has completed executing, you move on to the next step. In some cases, you may want to skip a few steps to do some special work. In those cases, you must mention the step you are skipping to. In the above example we can see something similar in step 3 and in step 1. In step 1 we can see that if the bicycle is okay we skip steps 2 and 3 and go to step 4. In this case step 2 and three will not be executed.

### 5.5.2 Flow Chart

There are some conventions for making flowcharts. Some instructions are represented by some special symbols. The figure 5.5 depicts some of them.

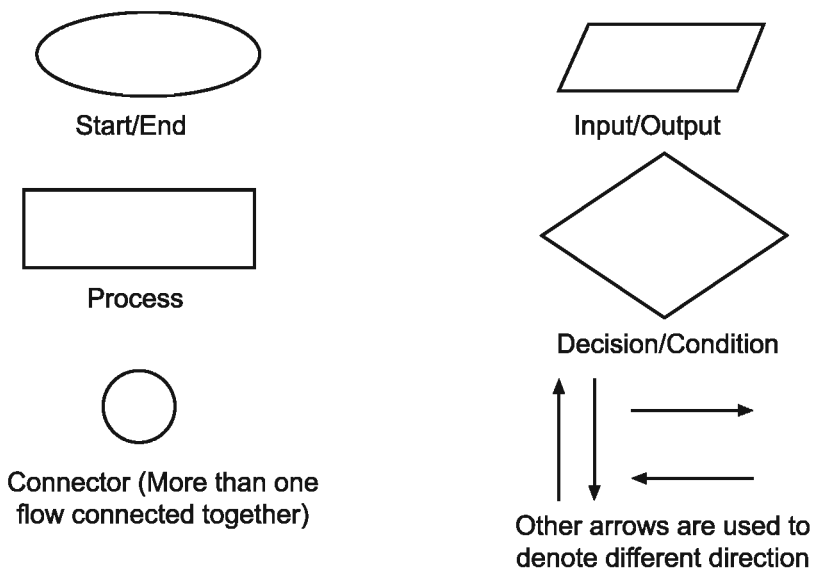

**Figure 5.5:** Different symbols used in a flow chart

The previously mentioned algorithm can be represented by a flowchart like this:

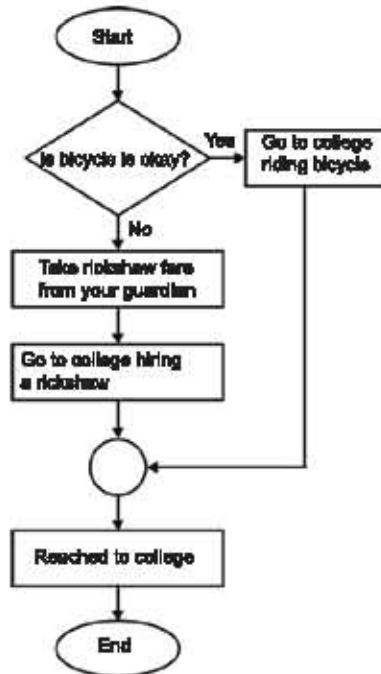

Figure 5.6: A flow chart of going to college

Once we write down the algorithm and the flow chart of our program, we can select a programming language and start coding. After we have finished writing our program, we have to write some test cases so we can test our programs for different scenarios. If any of the test cases do not return the desired output, we will know that there was some problems with our coding. Broadly there can be two kind of problems, we made a mistake with the algorithm or we made a mistake while writing our code; mistakes in codes are known as bugs. Finding and correcting errors in codes is known as debugging a code.

When the code produces desired outputs for all of the test cases, it is ready to be released. In the case of large applications and softwares, the programmer has to write user manuals so people know how to use their application.

The steps of writing a program are:

1. Explain the given problem thoroughly and with every minute details
2. Make an algorithm and flowchart for solving the problem
3. Write the code
4. Test and debug your code
5. Release the program

## 5.6 Program Design Model

---

Writing an effective computer program is a very arduous and time consuming process in real life. To streamline the whole process computer programmers use some design models like the waterfall model. In the waterfall model, the whole process for writing a program is divided into several definite and non overlapping steps. You can only move on to the next step when you have completed the current step. The process is one way like the flow of water in a waterfall, that is why it is called the waterfall model.

According to the waterfall model the steps of programming are - requirement analysis, designing, coding, testing, deployment and maintenance. Programmers spend 20-40% of the allotted time on requirement analysis and 30-40% time on coding if they are following the waterfall model. Rest of the time is spent on testing, debugging and deployment. This is logical as we have learnt over the years that if you do not spend enough time on requirement analysis before starting your coding, you will face troubles that will take more and more time later on to resolve. Documentation is a very important part in this model. If you maintain proper documentation throughout your project, one or more team members leave the team during the project you will have less trouble to adapt.

## 5.5 C Programming Language

---

The next section is practical work. The next section will only be meaningful if the students have a programming environment with computers or smartphones.

C is a very powerful programming language and we can use it to develop many different types of software and system applications like -

- System level programs which can control and manipulate hardware like keyboard, printer drivers are written in C. Also the gadgets and devices that contain microprocessors and microcontrollers use programs written in C language.
- Application softwares through which users can perform a certain task. Like the popular graphics editing software Adobe Photoshop.
- Compilers for different programming languages are written in C.
- Computer operating systems like Linux are written in C.
- Different database management systems like SQLite which we will learn later in this book, are written in C.

## C Compiler

To write and run a C program on your computer, first you have to download a C compiler software from the internet and install it. You can write the code in a text file and save it with the extension .c. Then the code must be compiled with the compiler software which will give you an executable file. In windows the executable files have the extensions .exe.

Most program compilers are command line based, so you have to write instructions to compile and run your program in command line. Thankfully to make life easier there are some IDE softwares available for the programmers, through which programmers can write their code, compile and run very easily.

Some IDEs are free to download on the internet. A popular IDE for C language is Code blocks. You can also use IDEs like Netbeans, Eclipse, Visual Studio to write C programs. There are many compilers available for android phones too.

## Hello World

Let us write a C program.

```
1  #include <stdio.h>
2
3  int main()
4  {
5      printf("Hello World!");
6
7      return 0;
8  }
```

### Program 5.1

Write the program in a text file and save it as program.c. Then if we compile and run the program we will see the following output.

```
Hello World!
```

In C language, to perform a particular task you have to write a function. The functions contain the necessary instructions to execute that particular task.

In the third line of the code, we can see the words `int main()`. This is called the `main()` function. We have an opening curly bracket in the fourth line and a closing curly bracket on the 8th line, indicating that the `main()` function starts from the 4th and ends in the 8th line. The 5th and 7th line hold two instructions and the 6th line is kept blank.

Any C program starts executing from the `main()` function. For example in the above code the program will start running from the 3rd line. This is why every C program has only one `main()` function.

The 5th line of the code contains the statement: `printf("Hello World")`. Here, `printf` is a function which can print something on the screen. In this case the `printf` function printed the text Hello World on the screen. But nowhere in our program do we have defined how the `printf` function works. This is actually defined in a file named `stdio.h`. This is called a header file. Header files contain some pre-build functions. To use these functions, you must include the header file in your program.

To include the header `stdio.h` we have written `#include <stdio.h>` in the first line of our code. With this every function defined inside `stdio.h` becomes available to us. Generally the `stdio.h` file contains functions related to inputs and outputs.

The 7th line of the code has the statement `return 0`. This is the last line of the `main` function and the program stops executing after this line. What this line does will be explained in the later parts of this chapter.

**Do it Yourself:** Write a C program that prints "I love Bangladesh" on the screen.

## Data types

We already know that a computer does all its calculation and processing on different types of data. C programming language gives us access to different data types to work with, `char`, `int`, `float` and `double` are among some of these data types. Let us have a brief introduction on these-

### Char

`Char` is the short form of character. This data type can contain only one letter of an alphabet, number system, symbols and punctuations. For example, in a `char` data type, you can store 'a', 'A', '9', '!' etc. A character data type takes 1 byte or 8bits of storage from computer memory. So we can keep 28 or 256 different data inside of it. It does not mean that you can keep 256 different variables together inside a `char` data. It means you have 256 different possible variables that can be stored inside a `char` data. One bit can only hold either 0 or 1. We can express two different things with 1 bit. Similarly with 8 bits we can express 256 types of different things inside `char` variables.

## Int

Int is the short form of the Integer number. You can only store integer numbers inside int data type. Int data type takes 4bytes or 32bits in computer memory. So we can keep 232 or 4294967296 different numbers inside an int. An integer number can be positive or negative so the range of int is from -214748364 to 2147483648. Any integer number within this range can be stored inside an int type variable.

## Float

Floating point numbers are stored inside a float type. It takes 4bytes of memory.

## Double

This is also used to store floating point numbers but double type has bigger range as it takes 8bytes in the memory.

Let us see some use of these data types inside a program.

### Example 1:

```
#include <stdio.h>
int main()
{
    char ch;
    ch = 'X';
    printf("The character is %c", ch);
    return 0;
}
```

### Program 5.2

If we compile and run the program we will get the output - The character is X. The char 'ch' statement in this program creates a char type variable which is named ch. We can give the variable any other name if we like. This is called a variable in C programming. We have to use %c if we want to print character type data. This is known as format specifier.

Some other format specifiers are shown in the table:

Data type	Format specifier
char	%c
int	%d
float	%f
double	%lf (Here l is the lowercase English letter L.)

The first character of the name can not be a number. Only special characters allowed in the name are underscore ( `_` ) and the dollar sign ( `$` ). The C programming language is a case sensitive language, so uppercase and lowercase letters are treated differently. For this reason `AAA`, `AaA` and `aAa` are valid names for three different variables. You also can not use the keywords as variable names.

Correct variable names	Wrong variable names
<code>age</code> <code>final_result</code> <code>student_1_marks</code> <code>student0</code> <code>__current_date</code>	<code>Ostudent</code> <code>final result</code> <code>greetings!</code> <code>my,name</code>

### Example 2:

A character type variable can hold any type of data. The following program will make the concept clearer.

```
#include <stdio.h>
int main()
{
    char ch;
    ch = 'x';
    printf("Value stored in ch is %c\n", ch);
    ch = 'y';
    printf("Value stored in ch is %c\n", ch);
    return 0;
}
```

### Program 5.3

Compiling and running the program will produce the following output:

```
Value stored in ch is x
Value stored in ch is y
```

We have to be able to determine what is going on with the program from the output. We can see that `\n` is used inside the `printf()` function. `\n` generates a new line while printing. That means any text after `\n` will be shifted to a new line on the screen. If `\n` was not used, the output would look like this:

```
Value stored in ch is x Value stored in ch is y
```



When a value is stored inside a variable like `ch = 'x'`, we call it as, `x` is assigned to `ch`. This is called an assignment operation. We can only assign one value at a time inside a variable.

**Do it Yourself:**

Experiment on the previous code by renaming the `ch` variable and compiling and running the program to see what output it produces.

**Example 3:**

The following program outputs the result of two numbers being added, subtracted, multiplied and divided.

```
#include <stdio.h>
int main()
{
    int number1, number2;
    number1 = 12;
    number2 = 4;
    printf("number1 + number2 = %d\n", number1 + number2);
    printf("number1 - number2 = %d\n", number1 - number2);
    printf("number1 * number2 = %d\n", number1 * number2);
    printf("number1 / number2 = %d\n", number1 / number2);
    return 0;
}
```

**Program 5.4****Output:**

```
number1 + number2 = 16
number1 - number2 = 8
number1 * number2 = 48
number1 / number2 = 3
```

To print integer type data, we have to use `%d` as a format specifier. Multiplication and division operations are expressed by `*` and `/`. We can introduce another variable called `result` in the code, to keep the results of the operations.

```

#include <stdio.h>
int main()
{
    int number1, number2, result;
    number1 = 12;
    number2 = 4;
    result = number1 + number2;
    printf("number1 + number2 = %d\n", result);
    result = number1 - number2;
    printf("number1 - number2 = %d\n", result);
    result = number1 * number2;
    printf("number1 * number2 = %d\n", result);
    result = number1 / number2;
    printf("number1 / number2 = %d\n", result);
    return 0;
}

```

### Program 5.5

Here the `number1 + number 2` is called an Expression in C programming. An expression is a piece of code which results in a value. Alternately the `number2 = 4;` is a statement. A statement represents a particular task, in this case assigning the value 4 inside the `number2` variable. Similarly the `result = number1 + number2;` is a statement as the result derived from the expression `number1 + number2` will be assigned to the variable `result` here. Each statement in C language ends with a semicolon(`;`).

#### Keyword:

C programming language has a restricted set of words which you can not use as the names of variables or functions. These words are called keywords. The list of keywords for C language are in the table below.

auto	double	int	struct
break	else	long	switch
case	enum	register	typedef
char	extern	return	union
const	float	short	unsigned
continue	for	signed	void
default	goto	sizeof	volatile
do	if	static	while

You do not need to memorise all of these keywords. You just have to keep in mind that you can not use any of these as variable or function names.

### Input Output Statements

We have already known how to use the `printf()` function to print outputs of our programs to the screen. Now let us move on to inputs. The following program takes two numbers as inputs from the user then will print the sum of the two numbers as output.

#### Example 4:

```
#include <stdio.h>
int main()
{
    int n1, n2;
    scanf("%d %d", &n1, &n2);
    printf("%d\n", n1+n2);
    return 0;
}
```

#### Program 5.5

When we compile and run the program we will see that the program is waiting for the user input. The output will be printed only when the user types in two numbers and presses the enter key.



Figure 5.7: Command line is waiting for user input

```
C:\Users\rafiit\Documents\Untitled1.exe
3 6
9
Process returned 0 (0x0) execution time : 110.476 s
Press any key to continue.
```

**Figure 5.8:** Typing two numbers separated by space and pressing Enter gives the output

As we can see the `scanf()` function is used for user inputs. We have to use the ampersand(&) symbol before the variables we want to take inputs for. The format specifiers inside the function are the same as we used in `printf()`.

#### Example 5:

Write a program that will take temperature in Celsius as input and provide output in fahrenheit units. Create a flow chart first before writing codes.

The relation between Fahrenheit and Celsius is:  $F = 1.8 \times C + 32$

The flowchart of this problem will look like:

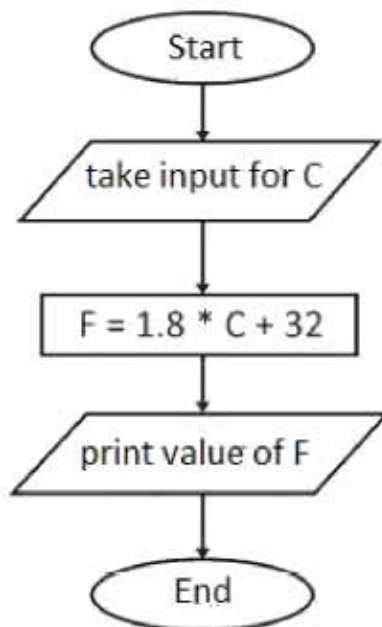

And the code will look like this:

```
#include <stdio.h>
int main()
{
    double C, F;
    scanf("%lf", &C);
    F = 1.8 * C + 32;
    printf("%lf\n", F);
    return 0;
}
```

### Program 5.7

#### Do it yourself

Write a program that takes temperature in fahrenheit as input and provides temperature in Celsius as output.

#### Conditional Statements

Computer programs can be designed and written in such ways that they can make decisions or choose a path depending on some pre-existing conditions. The expressions that are used in programming to write these conditions are called conditional statements. A conditional statement is either evaluated to be true or false.

#### Relational Operators

Co programming language has six operators that can compare two variables and produce Boolean results. These are known as relational operators:

Operators	Description
==	This operator compares if two numbers are equal or not. If they are equal it results in true, otherwise false.
!=	This operator compares if two numbers are not equal. If they are not equal it results in true, otherwise false.
:>	This operator compares if the number on the left is larger than the number on the right. If it is larger it results in true, otherwise false.
>=	This operator compares if the number on the right is larger or equal than the number on the left. If the right side number is larger or equal to the left side number then it results in true, otherwise false.
<	This operator compares if the right side number is less than the left side number. If it is less then results in true, otherwise false.
<=	This operator compares if the right side number is less or equal than the left side number. If the right side number is less or equal then results in true, otherwise false.

**If statement**

If statements are used in C programming to check if conditions hold or not.

```
if (conditional expression)
{
    statement 1;
    ....
}
```

If the condition written inside the first brackets evaluates to a true value then the code inside the if block will be executed. The if block consists of the code inside the curly braces. An if block can contain one or more statements.

**Example 6:**

Write a program that compares between two numbers and tells if they are equal.

```
#include <stdio.h>
int main()
{
    int n1 = 5, n2 = 7;
    if (n1 == n2)
    {
        printf("Numbers are equal.");
    }
    return 0;
}
```

**Program 5.8**

If we compile and run the program we will not see any output as the conditional statement inside the if is false. So the code inside the if block was not executed.

If block can be combined with else blocks:

**If-else statement:** If we have to do one task if the conditional expression evaluates to true and another task if it evaluates to false then we should use if-else statement.

```
if (conditinal expression)
{
    statement, if condition is true;
}
else
{
    statement, if condition is false;
}
```

```
#include <stdio.h>
int main()
{
    int n1 = 5, n2 = 7;
    if (n1 == n2)
    {
        printf("Numbers are equal.");
    }
    else
    {
        printf("Numbers are not equal.");
    }
    return 0;
}
```

### Program 5.9

When run the program will produce the following output:

```
Numbers are not equal.
```

The expression inside the if condition, `n1==n2` was false so no code inside the if block was executed. However the code inside the else block was executed. If the value of `n1` was equal to `n2` then the code inside if block would have been executed and the else block would be skipped. Then the output would have been -

```
Numbers are equal.
```

There is another similar block available in C programming that is the else if block. If we need to check another condition after the if condition then we have to use the else if block. **else if chain statement:** If multiple conditional expression will occur then use else if statement.

```
if (conditional expression 1)
{
    statement, if conditional expression-1 is true ;
}
else if (conditional expression-2)
{
    statement, if conditional expression-2 is true,
}
. . . . .
. . . . .
else
{
    statement, if both conditions are false ;
}
```

```
#include <stdio.h>
int main()
{
    int n1 = 5, n2 = 7;
    if (n1 == n2)
    {
        printf("Numbers are equal.");
    }
    else if (n1 > n2)
    {
        printf("n1 is greater than n2.");
    }
    else
    {
        printf("n1 is smaller than n2.");
    }
    return 0;
}
```

**Program 5.10**

So we can see that whichever conditional expression is evaluated to true value, that particular block will be executed and others will be skipped. If no conditions are fulfilled then the last else block will be executed.

Let us prepare a flowchart for the above code, it will look something like this -

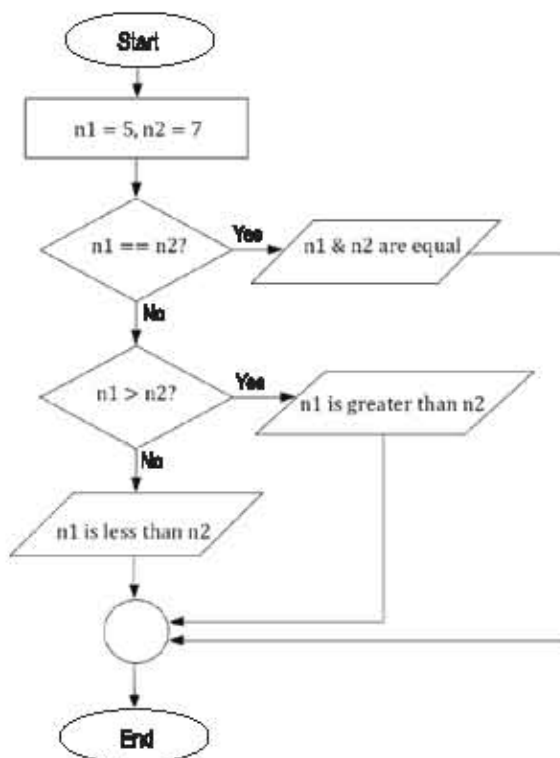



Let us see another similar example.

**Example 7:**

Assume we will take a students exam marks as input. Then we will display his or hers letter grade depending on the marks as output.

```
#include <stdio.h>
int main()
{
    int marks;
    scanf("%d", &marks);
    if (marks >= 80){
        printf("Your grade is A+\n");
    }
    else if (marks >= 70){
        printf("Your grade is A\n");
    }
    else if (marks >= 60){
        printf("Your grade is A-\n");
    }
    else if (marks >= 50){
        printf("Your grade is B\n");
    }
    else if (marks >= 40){
        printf("Your grade is C\n");
    }
    else if (marks >= 33){
        printf("Your grade is D\n");
    }
    else{
        printf("Your grade is F\n");
    }
    return 0;
}
```

**Program 5.11**

We can have many if and else if bundled together like this. In these cases when a single condition is evaluated to be true then the rest of the else if statements are skipped. For example if the marks is 75, the first marks >=80 condition will be evaluated first, which is false. So the program will move on to the next condition which is marks >= 70, which is true. So the code inside this block will be executed, the printf() statement will print the output on the screen. But after that no other else if or else statements will be examined.

**Do it yourself**

On the above program, what will be the outputs if the inputs mentioned below are introduced?

1. 98
2. 80
3. 79
4. 64
5. 37
6. 23
7. -20

**Logical Operators**

Sometimes we will need to combine two or more conditions to make a logical expression, just like we do with mathematical expressions. Logical operators are used to combine two or more conditions.

C programming language has three kinds of logical operators - &&(and), ||(or) and !(not) operators.

The and operator will have two conditions on either side. If both conditions evaluate to true, the expression will be true. If any one or both conditions are evaluated to false value then the whole expression is false.

A	B	A && B
True	True	True
True	False	False
False	True	False
False	False	False

**Table 5.2**

In the case of the or operator, it will have two conditions on either side just like the and operator. If any one of the conditions are true, the whole expression will be true. The Whole expression will be false only if both of the conditions are evaluated to a false value.

A	B	A    B
True	True	True
True	False	True
False	True	True
False	False	False

**Table 5.3**

For not operator, we will have only one condition. If the condition is true then the expression will be false and if the condition is false then the expression will be true.

A	!A
True	False
False	True

**Table 5.4**

**Example 8:**

Let us assume in a job recruitment the acceptable range of an applicant's age is between 18 and 35 years old. Write a program that will take the applicant's age as input and will output if the applicant is eligible to apply or not.

```
#include <stdio.h>
int main()
{
    int age;
    scanf("%d", &age);
    if (age >= 18 && age <= 35)
    {
        printf("Yes, you are eligible.\n");
    }
    else
    {
        printf("Sorry, you are not eligible.\n");
    }
    return 0;
}
```

**Program 5.12**

We can see that inside the if block we used two conditions combined by an && operator. Here if the input is true for both age >= 18 and age <=35 conditions then the whole expression will be true and the program will print "Yes, you are eligible.". The program will work if we write the expression as !(age < 18 || age >35) too.

**Example 9:**

Write a program that takes a number as input. If the input is divisible by 3 then the program will print 'Fizz' and if the input is divisible by 5 then the program will print 'Buzz'. If the input is divisible by both 3 and 5 then the program will print FizzBuzz.

If a number a is divisible by another number b then the remainder will be 0. In C programming, the remainder operator is % which is also known as the modulus operator. So if a%b == 0 then we can say that a is divisible by b.

```
#include <stdio.h>
int main()
{
    int num;
    scanf("%d", &num);
    if (num % 3 == 0 && num % 5 == 0)
    {
        printf("FizzBuzz\n");
    }
    else if (num % 3 == 0)
    {
        printf("Fizz\n");
    }
    else if (num % 5 == 0)
    {
        printf("Buzz\n");
    }
    return 0;
}
```

Program 5.13

### Do it yourself

Make a flowchart of the program above.

### Loop Statements

Loop statements are used when we need to repeat a single task. C programming has 3 kinds of loops - for loop, while loop and do-while loop. In this book we will demonstrate the uses of for and while loops.

### While loop

The syntax of a while loop is like this -

```
while (condition)
{
    statement;
    ...
}
```

If the condition is true, the code inside the while block will be executed. After the task is done the condition will be checked again, if the condition is still true, the while block will be executed again. Like this while the condition remains true the task will be executed repeatedly. Let us say we want to write a program that will print the words 'I Love Bangladesh' 5 times.

**Example 10:**

```
#include <stdio.h>
int main()
{
    int i;
    i = 0;
    while (i < 5) {
        printf("I Love Bangladesh.\n");
        i = i + 1;
    }
    return 0;
}
```

**Program 5.14**

Initially the  $i = 0$ ; statements assign 0 into the variable  $i$ . When the condition  $i < 5$  is checked, it evaluates to true. So the while block will start executing, it will first print the statement inside the `printf()` function. Then will increase the value of  $i$  by 1 with  $i = i + 1$ ; statement.

So ' $i$ ' has the value 1, now the  $i < 5$  condition will be checked again and again it will be true. The block will be executed as before and  $i$ 's value will be incremented by 1. So the loop will continue 5 times and then  $i$ 's value will become 5 and the condition  $i < 5$  will be false thus exiting the loop.

**Do it yourself**

Write a program that will print 'I Love Bangladesh' 100 times.

**Example 11:**

Write a program that will print every number from 1 to 100.

```
#include <stdio.h>
int main()
{
    int n;
    n = 1;
    while (n <= 100) {
        printf("%d\n", n);
        n = n + 1;
    }
    return 0;
}
```

**Program 5.15**

The flow chart of the program will look like this -

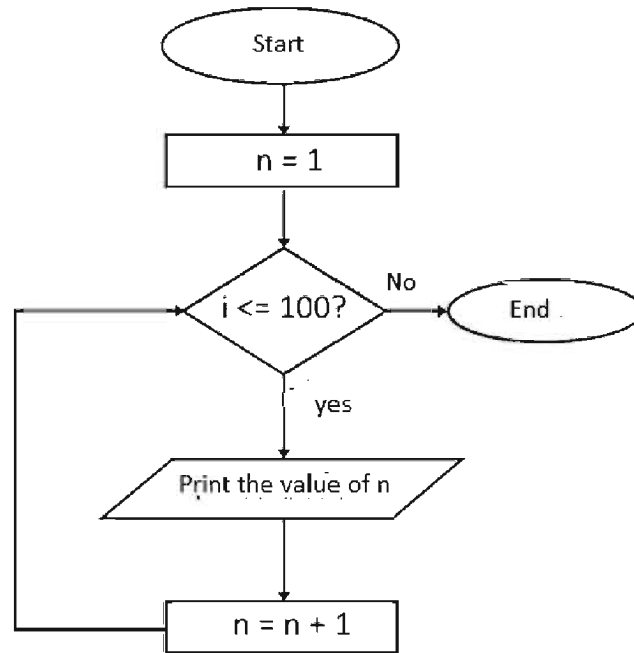

### Example 12:

Write a program that will print every even number between 1 and 100. This will be similar to the previous code but we just have to check if the number is even or not before printing. We already know that a number is even if it is divisible by 2.

```

#include <stdio.h>
int main()
{
    int n;
    n = 1;
    while (n <= 100) {
        if (n % 2 == 0) {
            printf("%d\n", n);
        }
        n = n + 1;
    }
    return 0;
}
  
```

We can write the program alternatively like this too -

```

#include <stdio.h>
int main()
{
    int n = 2;
  
```

```

while (n <= 100) {
    printf("%d\n", n);
    n = n + 2;
}
return 0;
}

```

### Program 5.16

The above program starts the value of  $n$  with 2 and increments the value of  $n$  by 2 in each loop. So this way the loop will print every even number from 2 to 100 and then exit the loop.

### Example 13:

Write a program that will output the sum of every integer number from 1 to 100. If we use the series equation then it can be done in just one line. But here we will use the while loop for this. Initially the sum will be 0 then we will increment the sum starting from 1 and ending after 100.

```

#include <stdio.h>
int main()
{
    int n, sum;
    sum = 0;
    n = 1;
    while (n <= 100)
    {
        sum = sum + n;
        n = n + 1;
    }
    printf("Result: %d\n", sum);
    return 0;
}

```

### Program 5.17

**Do-while loop:** In the case of the do-while loop, the loop statement executes before the conditional expression is evaluated. So whether the conditional statement is true or not, the loop executes at least for 1 time. This type of loops is called exit controlled loops.

The Syntax of do-while loop is-

```

do
{
    statement;
} while (condition );

```

Example 11 can be write by do-while loop.

```
#include <studio.h>
int main ()
{
    int n;
    n=1;
    do
    {
        printf ("%d\n", n);
        n= n+1;
    } while(n<-100),
return 0;
}
```

Program 5.18

### Do it yourself

Write a program that will output the sum of all odd numbers from 1 to 500. Use the while loop. Make a flowchart then write the code.

### For loop

The syntax of for loop in C is like this -

```
for (initialization; condition; increment)
{
    statement;
    ...
}
```

If we rewrite the program of summing 1 to 100 using for loop it will look like the following.

```
#include <stdio.h>
int main()
{
    int n, sum;
    sum = 0;
    for(n = 1; n <= 100; n = n + 1) {
        sum = sum + n;
    }
    printf("Result: %d\n", sum);
    return 0;
}
```

Program 5.19

### Do it yourself

Re write the previous while loop codes with for loops.



**Continue statement:** Continue statements are used inside loops. When the expression inside the continue statement evaluates to true then the execution skips the other statements and returns to the first statement of the loop. If it evaluates to false then the next statements are executed.

```
#include <stdio.h>
int main ()
{
    int i;
    for (i=1, i <=5; i=i+1)
    {
        if {i--}
        continue;
        printf ("%d", i);
    }
    return 0;
}
```

Program 5.20

**Example 14:**

Write a multiplication table program using for loop. Let us first make the flowchart for this.

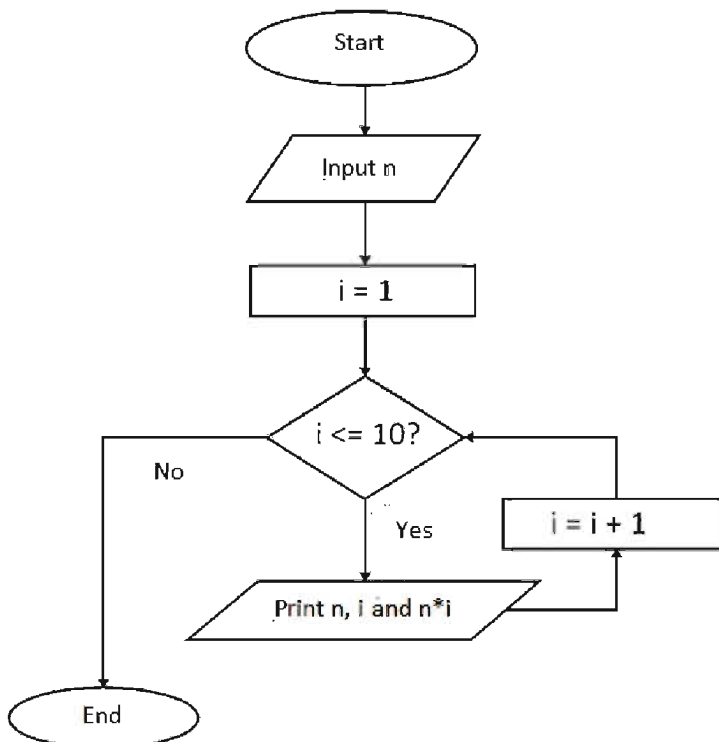

```
#include <stdio.h>
int main()
{
    int i, n;
    scanf("%d", &n);
    for(i = 1; i <= 10; i = i + 1) {
        printf("%d x %d = %d\n", n, i, n * i);
    }
    return 0;
}
```

We can use a loop inside another loop if we need. These are called nested loops.

### Array

We can assign only one value to a variable. But there are many cases where we need to work with numerous variables all of the same type. Like, if we want to output the results of 100 students in the class, we would need 100 different integer type variables. C program language has a special data structure for this type of work called an array. We can keep more than one variable of the same type inside of an array. The syntax for an array is -

```
data type name[number of elements];
```

### Example 15:

Write a program to store the exam results of 5 students, use an array.

```
#include <stdio.h>
int main()
{
    int marks[5];

    // assign marks to array
    marks[0] = 87;
    marks[1] = 82;
    marks[2] = 76;
    marks[3] = 85;
    marks[4] = 88;

    /* now print the marks */
    printf("%d\n", marks[0]);
    printf("%d\n", marks[1]);
    printf("%d\n", marks[2]);
    printf("%d\n", marks[3]);
    printf("%d\n", marks[4]);
    return 0;
}
```

Program 5.21

You will notice that at one place of the code there are some texts after the // symbol. Then there is some text between the /\* and \*/ symbols. These are called comments. When the program is executing comments are skipped. Comments are kept inside the code to increase readability of the code to programmers. If you start a line with // in C, what you write next until a new line is considered a comment. Similarly if you want to write multiple line comment then you have to put it between /\* and \*/ symbols.

In the above program we created an array named marks with `int marks[5];` statement. This statement says that the marks array is of integer type and the array will contain 5 elements. The first element of an array is stored in its 0th place, 2nd element in 1st place and like that nth element is stored in (n-1)th position. These positions are called the index of an array. It is very important to remember that, in C an array index starts from 0, not from 1. So we can depict the marks array like the following.

Value	87	82	76	85	88
Index	0	1	2	3	4

The advantage of array index is you can use loops instead of repeatedly writing the `printf()` statements 5 times.

```
for (i = 0; i < 5; i = i + 1)
{
    printf("%d\n", marks[i]);
}
```

There is a shortcut to assigning values to array indexes too.

```
int marks[] = {87, 82, 76, 85, 88};
```

You will notice that on the above code we did not mention the number of array elements while declaring the marks array like before. The compiler will then get the number of elements from the elements inside the curly braces.

If you want to take input from users for array indexes, this can be done easily too.

```
for (i = 0; i < 5; i = i + 1)
{
    scanf("%d", &marks[i]);
}
```

Array index will always be an integer number which starts from 0. If the array has n elements, the highest index will be n-1.

**Example 16:**

10 numbers are stored in an array, write a code for summing the numbers.

```
#include <stdio.h>
int main()
{
    int numbers[10] = {9, 76, 2, 45, 3, 81, 25, 33, 71, 10};
    int i, sum;
    sum = 0;
    for (i = 0; i < 10; i = i + 1) {
        sum = sum + numbers[i];
    }
    printf("Sum: %d\n", sum);
    return 0;
}
```

**Program 5.22**

When we declare a variable inside a function like `int sum;` then it has no value assigned to it. By default it contains a garbage value. So we need to initiate the variable with assigning a proper value to it. Like if we need we will assign 0 to sum to initiate. In the above program we need to do this before the `sum = sum + numbers[i];` statement or else sum will have garbage value.

`a = a + b` - this statement can be written in short in C like this: `a += b;`

```
for (i = 0; i < 10; i += 1)
{
    sum += numbers[i];
}
```

Similarly `i = i + 1` can be written as `i++` in short.

**Example 17:**

An array has 5 numbers. Write a code to reverse the serial of the numbers. If the array held 1,2,3,4,5 then after the program is executed it will hold 5,4,3,2,1.

Before we embark on writing this particular program. Let us start with an easier one first. Let's say we have two variables - a and b. We have to write a program so that a and b's values are swapped. How can we do this? The easiest answer is, by using a

third variable *c*. We will first assign *a*'s values to *c*, the both *ca* and *a* will contain the same values. Then we will assign *b*'s values to *a*. So now, *c* contains *a*'s original value and both *b* and *a* contain the original value of *b*. If we now assign *c*'s values to *b* then *b* will contain *a*'s original values. Thus the swapping of *a* and *b*'s values will be complete. The figure can explain the swapping a bit better.

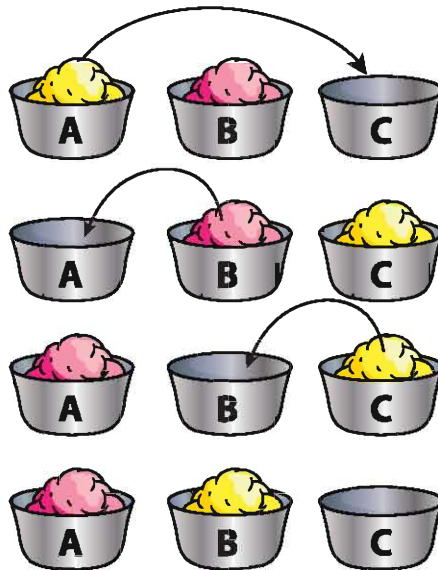

**Figure 5.11:** In the picture A bowl has yellow ice cream while B bowl has pink ice cream. We want to have pink ice cream in bowl A and yellow ice cream in bowl B.

```
#include <stdio.h>
int main()
{
    int a = 15, b = 9;
    int c;
    c = a;
    a = b;
    b = c;
    printf("Value of a is %d, value of b is %d\n", a, b);
    return 0;
}
```

**Program 5.23**

### Do it yourself:

Write an algorithm for the above program and make a flowchart.

Now let's get down to our original problem. We have to swap the values of the array's last element with the first. The second element with the fourth.

The code will look like this -

```
#include <stdio.h>

int main()
{
    int ara[] = {10, 20, 30, 40, 50};
    int n = 5, int i;
    int temp;

    for (i = 0; i < n / 2; i += 1)
    {
        // exchange value of ara[i] and ara[n-1-i]
        temp = ara[i];
        ara[i] = ara[n-1-i];
        ara[n-1-i] = temp;
    }

    for (i = 0; i < n; i += 1)
    {
        printf("%d\n", ara[i]);
    }

    return 0;
}
```

#### Program 5.24

Compile and run the program to see if it displays the intended outputs.

#### Do it yourself:

We used  $i < n/2$  condition inside the for loop. If we used  $i < n$  condition then what changes are needed to get the same results?

In C programming language we can store one character inside a character type variable. If we want to store more than one character or letters we need to use arrays of characters which are also known as strings. Although different programming languages have separate data types for strings, C does not have it.

**Example 18:**

The following code shows how you can take inputs and display outputs as strings.

```
#include <stdio.h>

int main()
{
    char name[80];

    scanf("%s", name);

    printf("%s\n", name);

    return 0;
}
```

**Program 5.25**

The above program will print the input string as output string. The last character of a string is always null character, represented with a '\0'. So if we declare a string with 80 elements like name[80], we have to remember that it will hold 79 characters as the last position is reserved for the null character.

Generally we use a loop to take inputs in an integer array. But we do not need to use loops for taking inputs to a character array or a string. We can use the modifier %s inside the scanf() function to take the entire string as input. We can not use the empty space character inside a string.

The following table shows how the string 'Bangla' is stored inside a character array.

Value	'B'	'a'	'n'	'g'	'l'	'a'	'\0'
Index	0	1	2	3	4	5	6

**Example 19:**

We will write a program that will calculate the number of characters in a string.

```
#include <stdio.h>
int main()
{
    char name[80];
    int i, length;
    scanf("%s", name);
    i = 0;
    while (name[i] != '\0')
    {
        i = i + 1;
    }
}
```

```

length = i;
printf("%s has %d characters.\n", name, length);
return 0;
}
    
```

**Program 5.26**

We start by initializing *i* variable with 0 and checking inside the while loop if `name[i]` has null character value or not. If we do not have null character value for the position we increment *i* and continue the loop. When we get the null character the program exits the loop and the value of *i* will represent the length of the string. The number of characters in a string is known as string length.

**Example 20:**

An array has several numbers. User will input a number and the program will check if that number is stored inside the array or not. Make a flowchart then write the code.

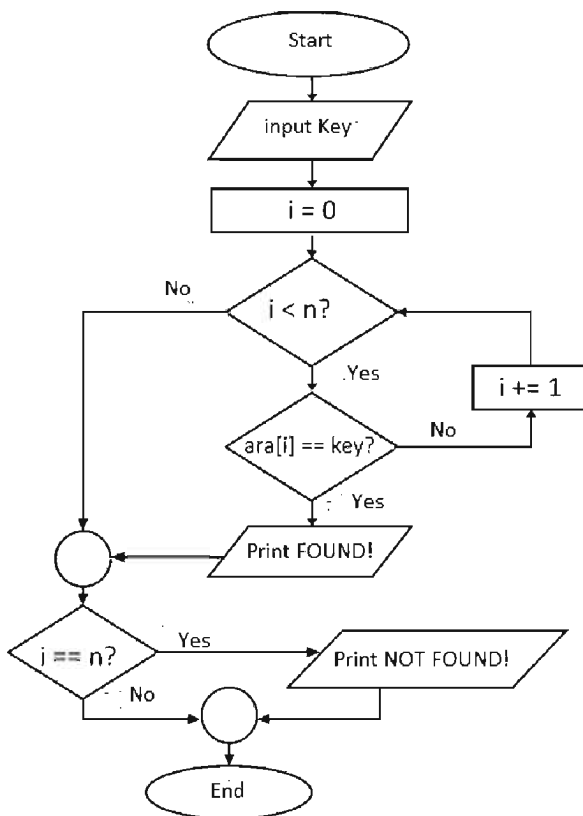



```
#include <stdio.h>

int main()
{
    int ara[] = {1, 2, 3, 5, 8, 13, 21, 34, 55};
    int key, i, n;

    n = 9;

    scanf("%d", &key);

    for (i = 0; i < n; i += 1)
    {
        if (ara[i] == key)
        {
            printf("%d is found in the array.\n", key);
            break;
        }
    }

    if (i == n)
    {
        printf("%d is not found in the array.\n", key);
    }

    return 0;
}
```

### Program 5.27

The program used a break statement. When a break statement is executed the program exits or breaks a loop. If we found the key inside the array we do not need to look anymore so we can exit the loop. There are two ways this program can exit the loop. If the key is found it executes the break statement and exits the loop. If the key is not found then the value of  $i$  will equal the value of  $n$  at the end of the array and the condition  $i < n$  will be false thus exiting the loop. So after the for loop we have to check if  $i$  equals  $n$  or not. If  $i$  is equal to  $n$  then we will know that we have not found the key, if  $i$  is less than  $n$  after the loop we will know that the break statement was executed and we have found the key inside the array. This method of searching is known as linear search.

#### Do it yourself

An array has six numbers : 5,8,1,9,4,10. Write down the steps of finding the number 4 from this array with the linear search method. Do not write the code, just write the steps.

## Function

While writing codes programmers have to do some steps over and over again. If those steps were written inside a function, we just had to call the function and the steps would be completed and we would not have to write the same steps many times. We do not need to know even how the function works inside, we still can use it.

This book already shows you the uses of `printf()` and `scanf()` functions. Printing text or numbers on screen requires many lines of codes. If there was no `printf()` function the programmers would have to write the same codes again and again just to print a few lines of texts or numbers. We do not need to know what code is written inside the `printf()` function. We just need to know how to use it. The same is true for the `scanf()` function. The `stdio.h` header file should be included if we want to use these two functions. If we include a header file we can use all the functions written inside the file within our code. C has many pre existing header files included with it, these are known as libraries. You can also create your own header file and functions if you need.

Before using a function you need to know three key information about it - what does the function do, what types of data does it take and what type of data does the function return. The `math.h` header file has a function that can calculate the square root of a number. The prototype of the function is `double sqrt(double arg)`. The first `double` is the return type of the function. This means the `sqrt` function returns a `double` type data. If a function does not return any data then the return type will be `void`. The `sqrt` is the name of the function. The `double arg` inside the first brackets indicate what types of data the function takes as inputs. These are called parameters of a function. The `sqrt` function takes a `double` type parameter. The data that is passed as a parameter is known as arguments. The use of this function is shown below.

### Example 21:

```
#include <stdio.h>
#include <math.h>

int main()
{
    double num, root;

    scanf("%lf", &num);

    root = sqrt(num);
```

```
printf("Square root of %lf is %lf\n", num, root);  
return 0;  
}
```

### Program 5.28

Why do we write the return 0 statement at the end of main() function?

When a program written in C is compiled and run, it starts executing from the main() function. If we declare main function as int main() then the compiler will determine that when the function finishes executing it will return an integer value. So we have to return an integer. The traditional way is to return 0, but you can return any integer if you want.

There are a lot of useful functions inside the math.h header file, one of them is pow(double x, double y). This function takes two double type numbers as parameters and returns xy value as return value. If we put 3 as the value of x and 2 as the value of y then the function will return 9.

### Example 22:

```
#include <stdio.h>  
#include <math.h>  
  
int main()  
{  
    double p, x, y;  
  
    scanf("%lf %lf", &x, &y);  
  
    p = pow(x, y);  
  
    printf("%lf to the power %lf is: %lf\n", x, y, p);  
  
    return 0;  
}
```

### Program 5.29

The math.h header file has many such mathematical functions.

We already have written code for a program that can calculate a string's length. We can do the same using a library function named strlen. This function takes a string as parameter and returns the string length as an integer. You have to include the string.h header to use this function.

**Example 23:**

```
#include <stdio.h>
#include <string.h>

int main()
{
    char name[80];
    int length;

    scanf("%s", name);

    length = strlen(name);

    printf("%s has %d characters.\n", name, length);

    return 0;
}
```

**Program 5.30**

Comparing two strings can also be done by using a library function called `strcmp`. This function takes two strings as parameters and if the strings are equal then returns 0, returns 1 if the first string is larger and returns -1 if the second string is larger. This function does not compare the string length though, it compares two strings lexicographically. This means if you arrange the strings according to dictionary rules, the strings which will come first are smaller and the string which comes later is larger.

**Example 24:**

```
#include <stdio.h>
#include <string.h>

int main()
{
    char s1[80], s2[80];
    int value;

    scanf("%s %s", s1, s2);

    value = strcmp(s1, s2);

    if (value == 0)
    {
        printf("%s and %s are equal.\n", s1, s2);
    }
    else if (value > 0)
```

```

    {
        printf("%s is greater than %s.\n", s1, s2);
    }
    else
    {
        printf("%s is smaller than %s.\n", s1, s2);
    }

    return 0;
}

```

### Program 5.31

#### Do it yourself

Write a program that will print an input string but exits the program when the user inputs the string 'quit'.

We have seen uses of different library functions in this chapter. C programming language has many library functions like these. You can read the documentation that comes with the compiler or browse the internet to know about them.

Now let us learn how to write a new function.

#### Example 25:

```

#include <stdio.h>

float celsius_to_fahrenheit(float celsius);

int main()
{
    float celsius, fahrenheit;

    scanf("%f %f", &celsius, &fahrenheit);

    fahrenheit = celcius_to_fahrenheit(celcius);

    printf("Fahrenheit = %f\n", fahrenheit);

    return 0;
}

float celsius_to_fahrenheit(float celsius)
{
    return (celsius * 9 / 5) + 32;
}

```

### Program 5.32

We created a new function `celsius_to_fahrenheit(float celsius)` in the program. This function takes a float number as parameter and returns a float number that is the fahrenheit form of the input. We have written the prototype of the function before the `main()` function.

```
float celsius_to_fahrenheit(float celcius);
```

Then we implemented the function after `main()` function. When we call the function from main we go to that function definition, then while returning from the function we go back to the main function and finish execution.

### Do it yourself

Use functions to take input of any integer number then display that numbers numerical table as output.

### Example 26:

We have already written codes for the multiplication table program earlier in this chapter. Now we will rewrite the program using functions.

```
#include <stdio.h>

void print_multiplication_table(int n);

int main()
{
    int num;

    scanf("%d", &num);

    print_multiplication_table(num);

    return 0;
}

void print_multiplication_table(int n)
{
    int i;

    printf("Multiplication table for %d -\n", n);

    for (i = 1; i <= 10; i = i + 1) {
        printf("%d x %d = %d\n", n, i, n * i);
    }
}
```

### Program 5.33

## Exercise

### MCQ

1. What is used in the C programming language to store the same types of data?
  - a. Function
  - b. Pointers
  - c. Structures
  - d. Arrays
2. What is the next step after you build an algorithm and a flow chart?
  - a. Debugging
  - b. Coding
  - c. Problem solving
  - d. Deployment
3. Which one is a C programming language variable?
  - i. Student-name
  - ii. Student name
  - iii. Studentname

Which one is true?

  - a) i and ii
  - b) i and iii
  - c) ii and iii
  - d) i, ii and iii

**Read the following code and answer the questions no 4 & 5:**

```
#include<stdio.h>
main(){
    Int a = 3, b;
    B = 2*a;
}
```

4. What will be the value of b after the program runs?
  - a. 3
  - b. 4
  - c. 5
  - d. 6
5. The output will be 3 when -
  - i. B = a++
  - ii. B = a--
  - iii. B += a

Which one is true?

  - a) i and ii
  - b) i and iii
  - c) ii and iii
  - d) i, ii and iii
6. Which one is a format specifier?
  - i. %d
  - ii. %lf
  - iii. %c

Which one is true?

  - a) i and ii
  - b) i and iii
  - c) ii and iii
  - d) i, ii and iii
7. What are the differences between compiler and interpreter?
  - i. Decreases memory space
  - ii. Error logging
  - iii. Running of the code

Which one is true?

  - a) i and ii
  - b) i and iii
  - c) ii and iii
  - d) i, ii and iii





3.

- What is a compiler?
- Algorithms are a prerequisite for coding, explain.
- Write a C program from the flow chart.
- Flowchart is an important step for programming, explain.

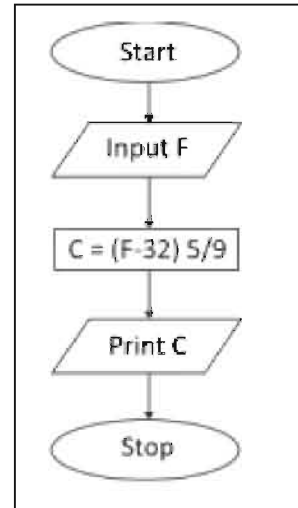

- In the annual sports competition of a college, the students of 11th class were divided into three groups - A, B and C. Roll no, 1 to 30 were put into group A, Roll 31 to 60 to group B and roll 61 to 100 into group C.
  - What is a program?
  - C is a case sensitive language, explain.
  - Write an algorithm for grouping the roll numbers according to the passage.
  - Write a C program with conditional statements for the problem described in the passage. Explain what you did and why.
- Maisha's father has a fever. She used a thermometer to see that his fathers body temperature was 103°F. But the room temperature is 30°C.
  - What is data type?
  - In what way interpreters are better than compilers? Explain.
  - Write a program to convert temperature in Fahrenheit to Celcius.
  - For the program to convert Fahrenheit to Celcius, flowchart is enough not an algorithm. Explain.
- Adnana wants to write a program that finds the GCD of two numbers. But he can not seem to figure out how to approach the problem. He went to his ICT teacher for help. The teacher broke down the problem in several small steps and Adnan understood what he had to do.
  - What is a programming language?
  - Why do the programmers break down a problem into smaller steps?
  - Find a solution for Adnan's problem.
  - Find the GCD of 8 and 3 using the program that you have written. Write the solution with steps.

## Chapter Six

# Database Management System

---



Data aggregation, collection and processing in an organized way is a huge challenge for the current world

Nowadays, almost everything we do, buy or get, can be done through the internet. We buy products online, pay our bills online, we get our banking services and healthcare services online, and almost all of our entertainment sources are now online. This vast amount of online resources need to be stored somewhere. Once we used to store our information only on papers and books. But now our information is handled by database management system. This surely made our life a lot easier but it has a certain number of challenges. Sometimes database systems can not be extended large enough, or data can not be retrieved fast enough or the security is compromised from cyber attacks. So the computer scientists are still working tirelessly on database management system with the goal of making it faster, more powerful and more secured. The students will get a basic overview of the database management system from this chapter.

**After completing this chapter students can**

- Explain the concepts behind a database management system
- Describe the work process of a database management system
- Learn the concepts of relational database management system
- Know the characteristics of a relational database management system
- Explain a total relational database management system
- Explain the concepts of database security
- Learn the importance of database security
- Explain the usefulness of data encryption
- Learn about the different ways to encrypt data practical
- Can create a database

## 6.1 Database Management

---

We work with information and data in every walk of our lives. In educational institutions, businesses, offices and even in our own residence too. Educational institutions are prime examples of multiple facets of database management system usage. Student admission, making a class routine, attendance, exam schedule, result tabulation and storage, tuition fee collection all of these activities need a lot of data to be computed and stored. For many ages, mankind has been keeping track of data with pen and paper. The advent of computers has made life a lot easier for us. Computers can store an enormous amount of information and process a lot of data at once, men with pen and papers can not compete with that. So we developed a bunch of software that uses this data storage and processing capabilities of computers and created database management systems.

Let's say for illness and other reasons a student was absent frequently from his classes. His parents want to know what classes their child missed in the last 3 months. In the old days, the parent would have to go physically to the school, meet with all of the teachers that are in charge of the classes, get the attendance book from all of them and check manually whether his child was absent from their classes in the last 3 months or not. This is a very tedious process and will take a lot of time. But if that school uses a database management system to feed all of the necessary and relevant data of the school, this information can be processed in a matter of seconds. Database is the system that stores the data and the system that operates the database is called the database management system.

### 6.1.1 Computer Memory and Files

We previously mentioned in an earlier chapter that, whenever a computer program works with some data, it puts them into a volatile memory. This volatile memory is known as the RAM. If the computer is shut down, the RAM is wiped clean. The RAM data can also be wiped clean if you shut down the running program. So store the necessary data we need to transfer them to a more permanent memory like the hard disk drive. The data in the hard disk drive is accessed through a system known as the file system. For example, we can create a text file and write some texts in it then save and close the file. Even if we shut down the computer and when we restart and open the file, we will find the previous written texts are there in the file.

When people first started using the computer for storing data, they used different programs that would write the data into files. To modify the data in those files or to process the data in those files, it would require different programs. Let's say we have an address book program where different persons' names, address, phone numbers are stored. If we need to, we can search and locate those information. Now we need a program that will let us perform data entry operations so we can enter new data. We need another program to search and find existing data. If the requirement suggests that we need to store the user's email address alongside other information, we need to rewrite the data entry and search programs. Requirements may arise so that we need to search with user names alongside their email addresses, we need to rewrite all of the programs. We can see that using only a file system, data management becomes a tedious and time consuming matter for the programmers. Database management systems make this work a lot easier to handle.

### 6.1.2 Database

In a literal sense, a database is a collection of data. But in the realm of computer science, a database is a software that can store a huge amount of data, that can search and find data, create, edit and delete data and process the data. Database management system is a program or a software that manages and controls a database.

In a broader sense a database can be of two types - relational database and NoSQL. The concept of relational databases was developed almost 50 years ago but it is still relevant and the most widely used database system. NoSQL database is relatively a new concept, its application in web based application is growing day by day. There are some limitations for which the NoSQL database isn't still widely used for all types of applications.

## 6.2 Relational Database

---

In relational databases, data is stored in one or multiple tables. Some tables can have relations between them. For example, a school database can have information on that school's teachers and students. Exam results, class attendance, class routines can also be stored in that database. Same type of information are usually put into the same table. For the information of a teacher we can have a teacher table and for the information of student we can have a student table. Exam results can be kept in a result table and the result table will have a relation with the student table so we can retrieve a student's personal information and result information in one move. All of these are compiled in a school database.

A database table has two parts - table header and table body. A table header contains the column names, types of data and the table body contains the actual data. Each row of the table contains a certain data. Firstly we must decide on what data and what types of data we will store inside a table. Let's say a table of a student can contain name, roll number, class, section, parents name, contact number, address etc.

Data types can be of different sorts. As we have seen, C programming has different data types, similarly a relational database has some defined data types. Different database developers define data types differently but some data types are common for every database, like - text, integer, decimal numbers, date etc.

Now let us look at an example of a database table.

**Table name: Student**

Student's name(text)	Roll number(integer)	Class(integer)	Section(text)	Parent's name(text)	Contact number(text)
Mijanur Rahman	1	4	Day	Abdur Rahman	0201456
Mosharraf Hossain	2	4	Day	Selina Khatun	0201456
Sourav Das	1	5	Morning	Ajay Das	021456
Shakil Mia	3	5	Morning	Mansoor Mia	021456

The first row of the student's table is the header of the table. Each cell of this row is a column and each column has a data type. Student's name is a name of a column and it's data type is text. Every cell of this column will contain text type data and it will contain a student name. Every row below the header contains a certain student's information. The second row contains the information of a student's named Mijanur Rahman, his roll number, class, section, and parent's information. Similarly each row will contain a student's information, one row will never contain more than one student's information. Each row of the table is also known as records. Each cell in the table is known as fields.

Some of the most popular relational database systems in the world are Oracle, MySQL, Microsoft SQL Server, PostgreSQL, Microsoft Access and SQLite. Among these, MySQL, PostgreSQL and SQLite are free and open source databases. This means you do not need to pay to use these databases and their source codes are open for all.

### 6.2.1 Null Value

There will be many occasions when some records' value in the database will be unknown, null value is used in such cases. In the student table there is a column called phone number but not everyone will have a phone number. Here Manik Mia has no phone number so the record is kept blank. Database will put a null value in that record. Let's assume there is another column called monthly family income in that table. If for privacy issues someone does not want to disclose their income, instead of putting 0 they will put up a null value. Just have to remember that if you do not have a value then keep the field blank do not put 0 or empty string in the place. If the record is blank, the database will treat it as a null value.

### 6.2.2 Primary key

A primary key is a column of the database table that can uniquely identify each record of the table. Ask yourself, in the student table which column can uniquely identify each student? Name columns would not work because there can be two or more persons with the same names. There is a student Mijanur Rahman in the student table, and he is of class 4. But there can be other students named Mijanur Rahman in other classes, or even in class 4. So a student's name can not be a primary key as it can not uniquely identify each record. Roll numbers can not be primary key either as different classes have the same roll numbers. Phone numbers can not be primary keys as not everyone will have a phone number. So in the student's table, there is no single column that is suitable to be a primary key. But the columns of class, section and roll number can be combined to make a primary key as these three information can uniquely identify any student in the table. When we use multiple columns to create a primary key, it is called a composite key.

When we are creating a database table, we have to mention which column is going to serve as the primary key beforehand. If there is no column suitable to serve as primary key, usually another column is added at first, this is a numeric column and the records will be different for each row. In regular practice, a column called 'id' is added which contains integer data type and has auto increment attribute. Auto increment attribute means, when you add another row to the table the value of id will be incremented by 1 automatically. So we do not have to handle the 'id' column, the database will handle it when it has an auto increment attribute.

In a relational database, every table needs to have a primary key. Although there are ways to create a database table without the primary key, in those cases the database itself generates a primary key.

In the table of students can create a primary key by combining the class, Section and Roll Number columns. But there will be a problem with using this method if we want to keep records of old students who have passed. A student from 5 years ago who used to study in Class 7, day shift with roll number 2 - we can not keep track of him because it will create conflicting records. So we need to create a separate column with different ids for each student. In some schools, the roll numbers are generated in such ways so that from the roll number we can determine which year the student got admitted and which section he is in. In some Institutions they keep a separate registration number which remains the same for every student no matter which class he is in.

Every adult person in Bangladesh has a National Identification Card. There we can identify each person with their unique NID, thus two people will not have the same NID number.



Figure 6.1: National Identification Card of Bangladesh

If we keep each adult person's information in the same or different tables, we can use the NID as the primary key.

### 6.2.3 Database Relation

Database relation is actually the relation between database tables. A database can contain one or more tables. When there are more than one table, usually there are relations between the tables. These relations can be of three types—

1. One to one
2. One to many
3. Many to many

### One to One relation

If two tables have an one to one relation, a row from one table can have relation to only one row of the other table. If we have a table called student\_info to store the general information of students and another table called student\_contact to store the contact information of the students, the tables will look like this.

**student\_info**

Roll (integer, primary key)	Name (text)	Class (integer)
1	Mizanur Rahman	6
2	Mosharraf Hossain	7
3	Subir Kumar	6

**student\_contact**

ID (integer, primary key)	Roll (integer)	Phone (text)	Email (text)	Address (text)
1	1	012345678	mizan@email.com	Adabor, Shyamoli, Dhaka
2	2	012345543	mosharraf@email.com	Sector 3, Uttara, Dhaka
3	3	014343678	subir@email.com	College Road, Mymensingh

Both of the tables described above have a one to one relation among them. For example, each row of the student\_info table contains information about a single student. Roll number is the primary key of the table(although roll number is not an ideal column to make a primary key but for the purpose of this example we assume it is.) Now the student\_contact table has each row corresponding to each row of the student\_info table. Roll number is the primary key of student\_info table but in student\_contact table roll number is the foreign key. When we use the primary key of one table to another, it is known as a foreign key. Foreign key creates the relation between two tables.

### One to many relation

Let's assume we have created a database table called result which stores all the exam results of the students. Each row of the table will contain the exam results of one particular subject.

**result**

ID (Integer, Primary Key)	Roll (Integer)	Subject (Text)	Marks (Decimal)
1	1	Bangla	70
2	1	English	76
3	2	Bangla	68
4	2	English	81



Here we can see that each row of the student-info table relates to multiple rows of the result table. The student with roll number 1 has results of two subjects in two different rows of the result table. This relation is called a one to many relation as one row of the student\_info table is related to two multiple rows of the result table. Roll is the foreign key for the result table.

### Many to Many

When two database tables are related as such that one row of one table is related to multiple rows of another table and one row of the second table is related to multiple rows of the first table, the relation is called a many to many relation.

Let us assume the school has many different clubs for different activities, like the cricket club, football club, science club chess club etc. A student can be a member of one or more clubs. Likewise a club can hold one or more students as its member. Let us look at the club table.

#### club

Name (Text)	Moderator (Text)	Established (Date)
Cricket Club	Mr. Ruhul Amin	1-1-2000
Football Club	Mr. Shahidul Islam	5-1-1998
Debating Club	Mr. Sumon Kumar	3-7-2002
Chess Club	Ms. Fatema Akhter	1-1-2001

The primary key of the club table is name, as no two clubs can have the same names. Now we need to create another table to establish the relationship between the student\_info table and the club table.

#### student\_club

Roll (Integer)	club_name (text)
1	Cricket Club
2	Cricket Club
2	Football Club
2	Chess Club
2	Debating Club

We need to create separate tables to establish the many to many relationship between two tables.

## 6.2.4 SQL

SQL or Structured Query Language is a programming language that is used in relational databases to read, write, create, update and delete data in a database. Though the SQL has its own format and structure, different commercial databases use their own query languages which are very close to the standard SQL.

What is the difference between SQL and regular programming languages? When a programmer writes a program to solve a particular problem, they usually express the algorithm to solve the problem in a particular format. A program has instructions for the computer so it knows when to execute what operations. SQL defines what is expected from the database and what to change in a database. SQL only defines which data to retrieve and which to store. How the operation is executed is entirely up to the database systems. This is why SQL is known as a declarative language. C and other C like programming languages are known as procedural languages. SQL language is designed such that even non-programmers can easily use it to write queries.

SQL can be divided into several parts. Most important of these are Data Definition Language or DDL and Data Manipulation Language or DML.

### Data Definition Language

DDL is primarily used to create, delete and index database tables.

### Data manipulation Language

DML is used to write queries to retrieve data from a table.

## 6.3 Creating Database

---

6.3 section is a practical section. This section is only meaningful when the students have access to a programming environment.

### SQLite

SQLite is a free and open source database. This database is used in web, desktop and mobile applications. Learning SQLite is comparatively easier than the other traditional databases, this is why it is widely used.

### Installing process

SQLite can be downloaded from its official website (<https://www.sqlite.org/download.html>).

After the download is complete, you can install it. SQLite can be used from the command line or terminal. There are some softwares with graphical user interfaces that make using SQLite easier. DB Browser for SQLite SQLiteStudio are these types of

softwares that can be downloaded for free from the internet. You can install SQLite in android phones and use it through different apps.

To create a new database in SQLite, you have to open the terminal and write a command that starts with `sqlite3` following the database name.

```
$ sqlite3 school.db
```

If you have already created the `school.db` database, the same command can be used to access the database through SQLite. After the software is on you can use different commands through the terminal; Like, to close the software you have to type in `quit`.

```
sqlite> .quit
```

### 6.3.1 Using Query

#### Creating a table

We will create several tables into the school database. In the first table, we are going to create is the student table. What data do we want to store in the student table?

- Student name
- Student's class
- Roll number
- Section

USE the CREATE TABLE query to create the table. The syntax is like this–

```
CREATE TABLE table_name (column_name column_type, ...);
```

Replace the `table_name` with what you want as the table name. Inside the first bracket write the name of each column and its data type separated by spaces. Each column information will be separated by commas.

So, to create the table of table we need to write:

```
CREATE TABLE student (name TEXT, class INTEGER, roll  
INTEGER, section TEXT);
```

To delete a table we need to use the DROP TABLE query.

```
DROP TABLE [Name of table];
```

Now you can create the table again using the CREATE TABLE query.

NOTE: You can use both capital letters or small letters while writing SQL queries. CREATE and create both are valid. But the general tradition is to use “all Caps”.

### Storing and Retrieving Data from Tables

The INSERT query is used to store data into a table. If we want to insert a student named Mizanur Rahman who is in Class 9 morning section and has roll number 3, we have to write:

```
INSERT INTO student (name, class, roll, section) VALUES
('Mizanur Rahman', 9, 3, 'morning');
```

SELECT query is used to retrieve data from the table.

```
SELECT * FROM student;
```

To see an organized output from the SELECT query add these two lines before the query.

```
sqlite> .mode column
sqlite> .headers on
sqlite> select * from student;
```

If we only want to see the names and class, we can write:

```
sqlite> SELECT name, class FROM student;
```

Let us insert some more data into the student table for later use.

```
INSERT INTO student (name, class, roll, section) VALUES
('Mosharraf Hossain', 9, 4, 'morning');
INSERT INTO student (name, class, roll, section) VALUES
('David Pandey', 9, 2, 'morning');
INSERT INTO student (name, class, roll, section) VALUES
('Promila Gosh', 8, 2, 'day');
INSERT INTO student (name, class, roll, section) VALUES
('Bazlur Rahman', 8, 1, 'day');
INSERT INTO student (name, class, roll, section) VALUES
('Sourav Das', 9, 1, 'day');
INSERT INTO student (name, class, roll, section) VALUES
('Tamanna Nishat', 10, 1, 'morning');
INSERT INTO student (name, class, roll, section) VALUES
('Maysha', 10, 1, 'day');
```

After the insert, use the SELECT query to see if all the data are inserted properly or not. While retrieving data using SELECT query, you can also add some conditions. Write the conditions after WHERE. If you want to see the data from only class 9 students you have to write:

```
SELECT * FROM student WHERE class = 9;
```

Here only those rows will be retrieved where the value of the class column is 9. You can use the following operators to write conditions.

Operator	Description
=	Equal
<>	Not equal
>	Greater than
>=	Greater or equal
<	Less than
<=	Less or equal

To retrieve the data of the students from morning section, we have to write:

```
SELECT * FROM student WHERE section = 'morning';
```

NOTE: While working with text type data use quotes. Do not write queries like the following:

```
sqlite> SELECT * FROM student WHERE section = morning;
Error: no such column: morning
```

Use AND and OR to combine multiple conditions. If we want to retrieve the data for Class 9 morning section students, we have to write:

```
SELECT * FROM student WHERE class = 9 AND section = 'morning';
```

To retrieve data of students that are either in class 9 or in morning section:

```
SELECT * FROM student WHERE class = 9 OR section = 'morning';
```

To retrieve data of students that are not in class 9 but in morning section:

```
SELECT * FROM student WHERE class <> 9 AND section = 'morning';
```

To retrieve data for students that are in Class 8, 9 or 10:

```
SELECT * FROM student WHERE class = 8 OR class = 9 OR class = 10;
```

Alternatively we can write:

```
SELECT * FROM student WHERE class IN (8, 9, 10);
```

### Deleting and Updating data

Let's assume we are inserting a new record into the student table.

```
INSERT INTO student (name, class, roll, section) VALUES ('Fardeen Munir', 10, 1, 'day');
```

Now there are two students in the class 10 day section who have the same roll numbers.

```
sqlite> SELECT name FROM student WHERE class = 10 AND roll = 1 AND section = 'day';
Maysha
Fardeem Munir
```

So either the old or the new entry is incorrect and now we have to delete one of them. To delete the record for the student named Fardeen Munir, we have to write a DELETE query.

```
DELETE FROM student WHERE name = 'Fardeen Munir';
```

A reminder that the above query will delete all the records that have Fardeen Munir in their name column. We have to be a bit careful when we want to delete a single record. For extra precaution, we can add some more conditions.

```
DELETE FROM student WHERE name = 'Fardeen Munir' AND class = 10 AND roll = 1 AND section = 'day';
```

Sometimes we will need to change or edit a record, for this we will have to use the UPDATE query. For example if we know the entry for Fardeem Munir is wrong and his roll number would be 3 we can write an UPDATE query like this:

```
UPDATE student SET class = 10, roll = 3 WHERE name =
'Fardeem Munir';
```

### Joining Multiple Tables

Relational tables can have multiple tables storing data and if needs arise we can retrieve data from multiple tables. This operation is called 'a join'. This is an important feature of the relational database system.

Let's say we create two tables called student\_info and result.

```
CREATE TABLE student_info (roll INTEGER, name TEXT;
CREATE TABLE result (roll INTEGER, subject TEXT, marks REAL;
```

We can see that there is a relation between these two tables using the roll column. The student\_info table contains each student's roll and name. The result table contains each student's roll, and marks from different subjects of the exams. So the relation between student\_info and result is one to many.

Let's insert some data first.

```
INSERT INTO student_info (roll, name) VALUES (1, 'Mizanur
Rahman');
INSERT INTO student_info (roll, name) VALUES (10, 'Mosharraf
Hossain');
INSERT INTO student_info (roll, name) VALUES (2, 'Maysha');
INSERT INTO result (roll, subject, marks) VALUES (1,
'Bangla', 79.0);
INSERT INTO result (roll, subject, marks) VALUES (1,
'English', 76.0);
INSERT INTO result (roll, subject, marks) VALUES (1,
'Mathematics', 74.0);
INSERT INTO result (roll, subject, marks) VALUES (10,
'Bangla', 82.0);
```

```
INSERT INTO result (roll, subject, marks) VALUES (10,
'English', 70.0);
INSERT INTO result (roll, subject, marks) VALUES (10,
'Mathematics', 98.0);
INSERT INTO result (roll, subject, marks) VALUES (2,
'Bangla', 75.0);
INSERT INTO result (roll, subject, marks) VALUES (2,
'English', 80.0);
INSERT INTO result (roll, subject, marks) VALUES (2,
'Mathematics', 100.0);
```

As we know, to get the data from the student whose roll number is 1, we have to write the following query.

```
SELECT roll, subject, marks FROM result WHERE roll = 1;
sqlite> SELECT roll, subject, marks FROM result WHERE roll =
1;
roll          subject          marks
-----
1             Bangla           79.0
1             English          76.0
1             Mathematics      74.0
```

This query does not show us the student name because the result table does not have a student name column. To get a student name we have to query the student\_info table too. The query would be like the following:

```
sqlite> SELECT name, result.roll, subject, marks FROM
result, student_info WHERE result.roll = 1 AND result.roll =
student_info.roll;
name          roll          subject          marks
-----
Mizanur Rahman 1             Bangla           79.0
Mizanur Rahman 1             English          76.0
Mizanur Rahman 1             Mathematics      74.0
```

Note that we wrote result.roll instead of roll in the query as both tables have a column named roll. The result.roll = student\_info.roll part joins the two tables. If we want to see every student data, we have to omit the result.roll = 1 part. Then the query would look like this;

```
SELECT name, result.roll, subject, marks FROM result,
student_info WHERE result.roll = student_info.roll;
```

### 6.3.2 Sorting

Sorting means arranging some things following a certain serial. This serial can be of numbers, alphabetical or something else. We can sort a student's list by their names, by their roll numbers or class. We can sort them by ascending or descending order. We have many algorithms in computer science for sorting. Some are complex, some are simple, some are very fast some are slow. But for database sorting, we do not have to think about sorting algorithms much as the database system will handle the sorting part. We just have to mention the sorting criteria and order and the database will do the rest. To sort a query we just have to add ORDER BY following the column named and the result of the query will be sorted in ascending order. If we want sorting by descending order we have to add DESC at the end.



We can sort the data of the student table in many different ways. Some examples are shown below. Students are encouraged to try different sortings on their own in SQLite. Sorting by class in ascending order:

```
SELECT * FROM student ORDER BY class;
```

Sorting by class in descending order.

```
SELECT * FROM student ORDER BY class DESC;
```

Sorting by class in ascending order and again sorting by roll number in descending order.

```
SELECT * FROM student ORDER BY class DESC, roll;
```

Sorting by section in ascending order, sorting the same students by class in descending order and finally sorting them by roll number in ascending order.

```
SELECT * FROM student ORDER BY section, class DESC, roll;
```

### Do it yourself:

What result would you get from the following query?

```
SELECT * FROM student ORDER BY class DESC, section, roll;
```

We have already mentioned that SQL is a declarative language. What is being done is important, how it is done is not of our concern as it is handled by the database system. Sometimes a database table can hold a huge amount of data, millions and billions of records. In that case, any query operation will take a lot of time. For example, if a database table has every student's data that appeared in HSC exam from Dhaka board, the table will contain a million or more records. Now if we use a SELECT query to retrieve a student's record from the table it will take a long time as the database will perform linear search on the table and check each row for match. We have already explained how a linear search works in previous chapters, the more data a table has the more time the linear search will take.

Indexing is a process where we can ensure data to be found quickly. When we search a word in a dictionary it does not take too much time though there are a lot of words in there. That is because the words in a dictionary are arranged serially and going to one

page we will immediately know if our desired word can be found on that page or the next. If the data in a database table is sorted, we can use binary search to find our desired data very quickly. If we use indexing on a particular column, using the column value to search a record becomes much easier. How a database does the indexing is not of our concern as the database does the indexing by itself. We just have to point out which column we want to be indexed. We can even create indexing on multiple columns.

If we want to create an indexing on the class column we have to write:

```
CREATE INDEX student_class_idx ON student (class);
```

Indexing not only makes searches faster but if we want to do sorting based on that column it becomes instant too. After the indexing is done, we can write `SELECT * FROM student ORDER BY class` and the sorting will be done much faster than usual. We can create unique indexes if we want, so that the same data does not repeat in the database. For example, if we want that there will be only one person in a class and in a particular section with a unique roll number we have to write:

```
CREATE UNIQUE INDEX unique_student_idx ON student (section, class, roll);
```

We can do this after the table has been created too. We can even do the indexing after data has been inserted into the table. We can make more than one column unique if we want.

We know that there is already an entry of a student in class 10 day section with roll number 1. Now if the unique indexing is done we cannot insert another record with the same fields. Previously we have shown that two records with the same fields were inserted and we had to delete or update one record. If we use unique indexing we can avoid that.

```
sqlite> INSERT INTO student (name, class, roll, section)
VALUES ('Maysha', 10, 1, 'day');
Error: UNIQUE constraint failed: student.section,
student.class, student.roll
```

Note that if we declare a column as primary key the database automatically indexes that column. We do not need to index it again.

Indexing creates some problems too. Firstly, after the indexing is done a create, update and delete operation changes the indexing too. Though the database handles the indexing part but the INSERT, UPDATE, DELETE operations take more time than usual. Secondly indexing requires extra spaces in the hard drive, so you have to consider that too.

To remove an indexing you have to write DROP INDEX and then the index name. Like:

```
DROP INDEX student_class_idx;
```

## 6.4 Data Security

---

Database security is a vital issue as almost all databases hold some sensitive and private information. The issue of database security can be tackled from many different angles.

First and foremost we must ensure the safety of data, so there is no data loss. For this regular and frequent backups of the database should be generated. Issues of hardware or software or networks can cause erroneous data which is known as data corruption. If you keep the backups in the same physical storage, any data corruption or a possible hard disk crash can affect the backup copy too. This is why backups are usually stored in separate physical drives. Natural disasters like fire or earthquakes can damage physical copies too, so data centers are usually located in different geological locations.

Secondly, a database is always in risk of malicious cyber attacks that can compromise the privacy of the data. This is why every database is password protected. You can design the database security in such a way so that not every user has access to every database table. Some users have only access to perform SELECT queries. You can configure the permissions of the database tables to ensure security. SQLite databases may not have this type of extensive security measures but commercial database systems like Oracle, PostgreSQL, MySQL databases offer many types of protections.

### 6.4.1 Data Encryption

When a database stores data in physical drives or sends data through networks, data is usually encrypted to ensure privacy protection. The concept of data encryption is nothing new. It is even older than the advent of computers and digital systems. In ancient times, people used to encrypt their letters and correspondence through secret codes so the privacy is protected if it falls into the wrong hands. Roman emperor Julius Caesar used to encode his letters so that only the receiver of the letter can decode and read the letters. During the first and second world war, many mathematicians worked on encryption systems to ensure the crucial data is protected from enemy hands. The section of the computer science that deals with data encryption is known as cryptography.

The basis of encryption is to encode the original data. This is the responsibility of the sender. The original data is called plain text and the encrypted data is called a ciphertext. It's the job of the receiver to decipher the received signal and get the plain text back. Encryption systems are mainly of two types:

1. Symmetric key cryptography
2. Asymmetric key cryptography

### Symmetric Key Cryptography

In this system a special key is used to encrypt data and both the sender and receiver holds the key. The sender encrypts the data with the key and the receiver receives the data and uses the key to decrypt the data.

Though the system is very effective, it has some downfalls. Firstly, the key has to be kept a secret from anyone else but the sender and the receiver. It sounds easy but it is not that simple. Secondly, if the sender is sending data to multiple receivers it has to use different keys for each of the receivers which is very cumbersome. If an ecommerce site has a million users, managing a million different keys to encrypt data is not very realistic.

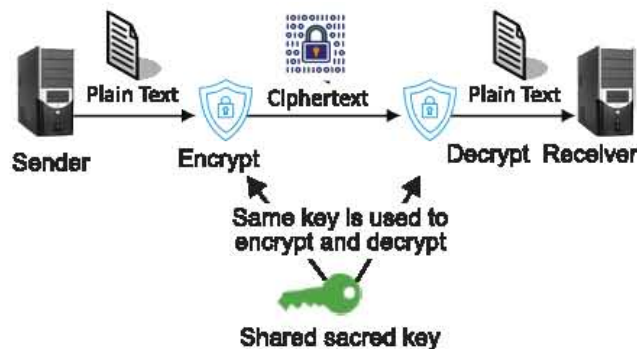

Figure 6.2: Symmetric Key Cryptography

### Asymmetric Key Cryptography

In this system every user uses a special algorithm to generate a pair of keys, one of which is a public key and another is a private key. Each system shares their public key with everyone else. Let us assume A, B and C have the public key. Now if A sends data to B, it encrypts the data with B's public key. The data can not be decrypted without B's private key. Similarly to send data to C one will encrypt the data with C's public key and the data can only be decrypted using C's private key.

### 6.4.2 Characteristics of RDBMS

Edgar Frank Codd first proposed the concepts of a relational database. He mentioned 12 characteristics that must be present in any relational database. Every database system provider maintains these 12 characteristics when they develop their database systems. Some common characteristics of an RDBMS are:

- A relational database can perform all sorts of work if it maintains its different tables and their relationships. Every data of the database is stored within tables. Each data will be stored as a record in the row and column system of a table.
- Any data of the database can be retrieved using the table name, primary key or the row and column name. For example, to retrieve the data of the class 10 student who has the roll number 1 we have to write:

```
SELECT name FROM student WHERE roll = 1 AND class = 10;
```

- A database should have the system to insert, update or delete one or more rows. For example to transfer a class 9 student's data into class 10 we have to write a query like:

```
UPDATE student SET class = 10 WHERE class = 9;
```

- Any internal change in the database will not affect a database user. The format of the physical drive might change and so the database too. But this change will not affect how a database user uses the database system.
- Software applications can be developed that can access and use the database interface. These systems can change the database if they need.
- Where the database stores its data is not a concern of the database users. The database can store the data across multiple physical drives or one but the database user will feel like it is stored in one single physical drive.

### 6.4.3 Use of RDBMS

The use of RDBMS in the current world is extensive and rapidly growing. Bangladesh is just dipping their feet in the vast fields of information technology in recent times, so there is a lot to be done.

Many government and non government organizations use databases to store different types of information. The national ID information is stored in the national ID database. Passport, driving licence, tax information, land and agricultural information all are now being stored in databases.

E-commerce websites provide services to buy and sell products and services. Here the website has to manage and handle many different types of client and product information which is handled by a database. Banking, insurance and other financial institutions use relational databases to manage their data. Educational institutions use databases to store and retrieve information about students, their results and routines.

#### **6.4.4 Corporate Database**

Large corporations work with a huge amount of data. Most of these works are codependent on each other. For example, you can not sell a product if the product is not in your inventory. The type of software that manages this type of work is known as ERP or Enterprise Resource Planner. An ERP software has different modules and different organizations use different modules according to their needs. Some common ERP modules are accounts, inventory, payroll, customer relationship management etc. All of these works are run with data, so data management is the most crucial part here. Large corporations have branches in different cities and even in different countries too. Data of every branch must be aggregated to provide a clear view, which is one of the main challenges of an ERP system. Ensuring the privacy and protection of data is also integral.

#### **6.4.5 Database in Government Organization**

Government organizations work with citizen's information so database management is an important part of modern day government works. But improper use or non use of databases can cause loss of synchrony among the different government organizations. Improper management of data causes distress among citizens and wastes a lot of work hours for the government. A good example for this is our national 'id' database. The government tasked an organization to collect and properly manage all citizens' data in that database. So though the government already has the necessary information, citizens have to fill up those same information during passport or driving licence registration. If the databases were to be synchronised among these organizations, these hassles could have been avoided.

Another example is in our education system. When a student passes their HSC exam they need to fill up forms for admission exams for different universities. But our educational boards already possess the student data including the result data of SSC HSC and other exams of a student. SO if their databases were made available in a way to the university authority then the students would not have to go through the hassle of filling up forms with the same information. Already some universities have taken steps to reduce the hassle and automate the process.

Another great use of databases in government institutions is to make data driven decisions. If the database is managed properly, those data can be analysed and used to make data driven. Analysing past data and making future decisions based on them will yield much better results in the fields of agriculture, health and education. If our health sector was data driven any pandemic situation would have been detected much sooner and the future decisions much easier to take.

The main challenge for database management in government organizations is to ensure the data security, ensure proper data collection and management, and employ an able workforce into the program. Most importantly every organizational database must be synced together to avoid redundant data input and unnecessary hassle to the general population.

## Exercise

### MCQ

1. What is the process used to convert root data into another format?
  - a. Manipulation
  - b. Validation
  - c. Encryption
  - d. Decryption
2. Which data field can be sorted?
  - i. Text
  - ii. Currency
  - iii. OLE objects
 Which one is true?
  - a) i and ii
  - b) i and iii
  - c) ii and iii
  - d) i, ii and iii

**Read the following passage and answer the questions no 3 & 4:**

The principal of a college decided to store all kinds of data related to the college into a database. After the task was done, a list of the weak students was derived from the database.

3. What was the method of the listing?
  - a. Sorting
  - b. Query
  - c. Indexing
  - d. Encryption
4. Because of the principal's decision to create a database -
  - i. All the data will be secured
  - ii. All the data can be sorted as required
  - iii. Any kind of data can be searched quickly
 Which one is true?
  - a) i and ii
  - b) i and iii
  - c) ii and iii
  - d) i, ii and iii

Roll	Name	GPA
01	X	5.00
02	Y	4.50
03	Z	5.00

5. To find out who got GPA = 5.00 from the table in SQL query is needed. Complete the query
 

```
SELECT NAME FROM Student
```

  - a. WHERE "GPA" = "5.00"
  - b. WHERE "GPA", "5.00"
  - c. WHERE GPA = 5.0)
  - d. WHERE GPA is 5.00



6. What is the relation between primary key and foreign key?

- i. One to one
- ii. One to many
- iii. Many to many

Which one is true?

- a) i and ii
- b) i and iii
- c) ii and iii
- d) i, ii and iii

7. What is the main responsibility of a Database management System?

- i. Creating database
- ii. Data entry and storage
- iii. Reporting and printing data

Which one is true?

- a) i and ii
- b) i and iii
- c) ii and iii
- d) i, ii and iii

## Creative Questions

1.

TID	T NAME	Subject
101	Mr. Rayhan	English
102	Mr. Kaiser	ICT
10.	Mr. Yaqub	Biology

Teacher's table

TID	Group	Time
101	Science	10:00
101	Humanities	10:45
102	Science	10:45
102	B. Studies	10:00
103	Science	11:30

Routine table

- a. What is a database?
  - b. What is the purpose of a query command?
  - c. Describe the data types of Teachers' table.
  - d. How can you create a relation between the two tables? Explain.
2. Three students were tasked with finding a student's data from the school's results database. The first student used a conditional command, the second student used sorting on the table but the third student was the fastest in finding the data.
- a. What is data encryption?
  - b. Describe the type of database used to store NID information.
  - c. Explain the strategy of the second student.
  - d. What strategy did the third student use? Why was it the fastest? Explain.

3. The authority decided to update the voter list of A area for the upcoming election. Surveyors were tasked to collect voters' name, father's name, religion, birth date and location. A database was created with the collected data. Another database file was created using the date of birth, name and age for statistical purposes.
- What is SQL?
  - Explain the differences between a primary key and a foreign key?
  - Describe the data types that will be used for the voter list database.
  - How will you make a relation between the two database files? Explain.

ID	Name	Address
1001	Ariful Haque	Khulna
1002	Shajeda Jannat	Dhaka
1003	Tahmid Salehin	Jamalpur

Sl.No.	Designations	Salary
1	Manager	45,000
2	Officer	30,000
3	Accountant	25,000

4. Saitama and Boros were tasked to find people from these two tables who have 30000 or more salary. They have to find the names and designations. Boros used a conditional statement to find that but he took more time. Saitama suggested that creating another file will make the process faster but the data entry will require more time.
- What is an RDBMS?
  - Why is SQL such an important database tool?
  - Add some columns and create relations between the two tables.
  - Do you agree with Saitama's solution? Explain.

5.

Name	Roll	DOB	Tuition Fee
A	1011	02-2-2002	3500/-
B	1012	15-5-2003	4000/-
X	1013	22-8-2002	4200/-
Y	1014	27-3-2001	4100/-

Roll	Subject	Number	GPA
1011	ICT	70	A
1012	ICT	85	A+
1013	ICT	90	A+
1014	ICT	75	A

- What is a query?
- Describe the importance of data security in a database.
- How will you insert another column titled address between Roll and DOB in table 1? Explain.
- What type of relation can be created between the two tables? Explain.

6. The Statistics Bureau and Agricultural Department of Bangladesh created a list of farmers in Bangladesh. They collected information like name, date of birth, what field they work on(i.e. poultry, cultivation, pisciculture etc.), family members, monthly income etc.
- a. What is a cypher text?
  - b. Explain the importance of data encryption.
  - c. What should be taken into mind while creating a database for the government?
  - d. After indexing a database, INSERT, UPDATE, DELETE commands take more time. Explain .

**The End**

**Academic Year**

**2022-2023**

**ICT XI-XII & Alim**

নারী ও শিশু নির্যাতনের ঘটনা ঘটলে প্রতিকার ও প্রতিরোধের জন্য ন্যাশনাল হেল্পলাইন সেন্টারে  
১০৯ নম্বর-এ (টোল ফ্রি, ২৪ ঘণ্টা সার্ভিস) ফোন করুন



**Ministry of Education**